



Product Data

30HXA, HXC076-271 Condenserless and Water-Cooled Liquid Chillers 50/60 Hz

75 to 265 Tons (264 to 931 kW)

Comfort *Link*™

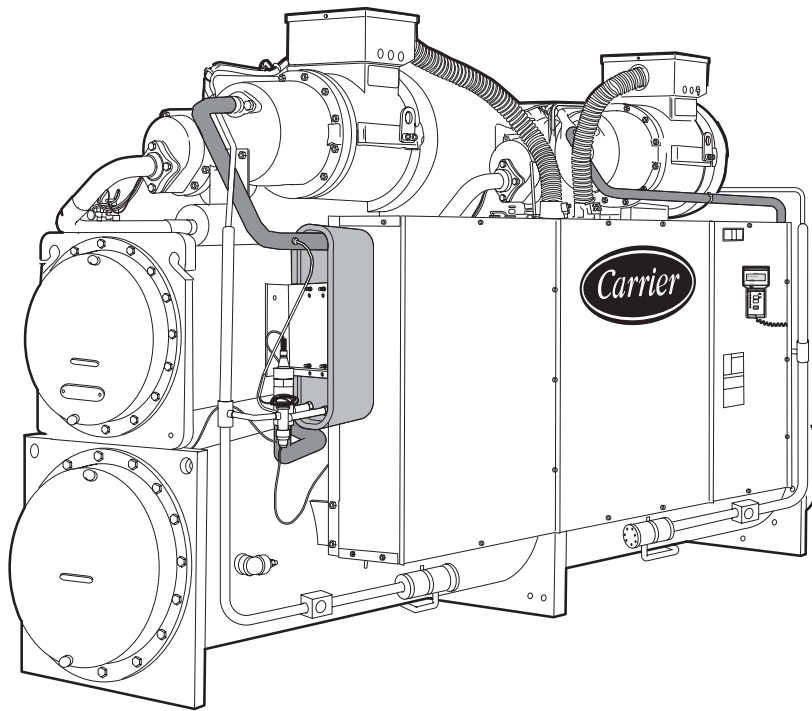

Water-cooled and condenserless chillers designed from the ground up to meet the needs of today and tomorrow:

- Unit fits through a standard door with no disassembly required
- Chlorine-free HFC-134a refrigerant
- Dual independent refrigerant circuits
- Smooth compression using twin screw compressors
- ARI certified efficiencies to 0.53 kW/ton

Features/Benefits

Quality design and construction make the 30HXC (Water-Cooled) and 30HXA (Condenserless) units the preferred choice

Easy installation

The 30HX chiller has a compact design that fits through a standard door opening and requires minimal indoor space. The 30HX chiller is delivered as a complete package for easy installation. There are no extra controls, clocks, starters, or other items to install.

The 30HX unit also provides a single location electrical power entrance (using the accessory field-installed control power transformer) and quick, easy piping (using victaulic-type clamp-on couplings).

The 30HX 208/230-v, 230-v, 460-v and 575-v units are designed in accordance with UL (Underwriters' Laboratory, U.S.A.) and UL, Canada (Underwriters' Laboratory, Canada) standards to minimize electrical inspection time.

**ASHRAE
90.1
COMPLIANT**

A quick start-up is assured once installation is complete, since each 30HX unit is manufactured at an ISO 9001:2000 listed manufacturing facility to guarantee quality. In addition, all 30HXC units are tested under load at the factory to provide reliable start-up. NOTE: Units shipped with optional nitrogen charge are tested for proper operation of the electrical components but are not run-tested at the factory.

Easy operation

The 30HX units have a quiet, low-vibration design featuring screw compressors.

Efficiency levels of the 30HX units meet or exceed energy efficiency requirements of ASHRAE (American Society of Heating, Refrigeration and

Air Conditioning Engineers) 90.1-2001 and CSA (Canadian Standards Association) for both full-load and part-load operation, thus saving on operating costs through lower electrical costs. All 30HX units are also rated in accordance with ARI (Air Conditioning and Refrigeration Institute, U.S.A.) standards. The 60 Hz 30HXC units are ARI certified.

The 30HX controls are fully automatic. The leaving-fluid temperature is directly controlled to within .5° F (.3° C), and the entering-fluid temperature is continuously monitored to detect load and flow changes.

Dual, independent refrigerant circuits provide reliable, dependable cooling, and the 30HX units use medium-pressure HFC-134a refrigerant to

minimize stress on the compressors and ensure a long life.

From a service standpoint, the 30HX units offer the following features:

- Use of HFC-134a refrigerant, which has no planned phase-out in its future
- Mechanically cleanable cooler and condenser (30HXC units)
- Twin-screw compressors, which require no routine service or maintenance
- Easily accessed service information includes suction and discharge pressure and temperature using standard Navigator™ display module
- All parts are available through Totaline parts stores.

DUAL INDEPENDENT REFRIGERANT CIRCUITS

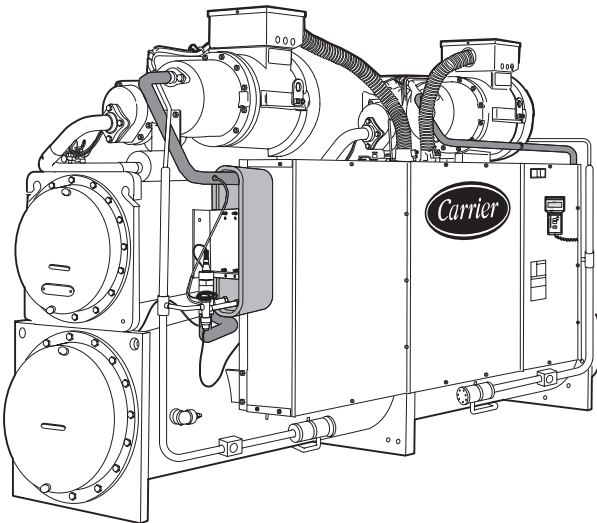

NAVIGATOR IN DISPLAY MODE

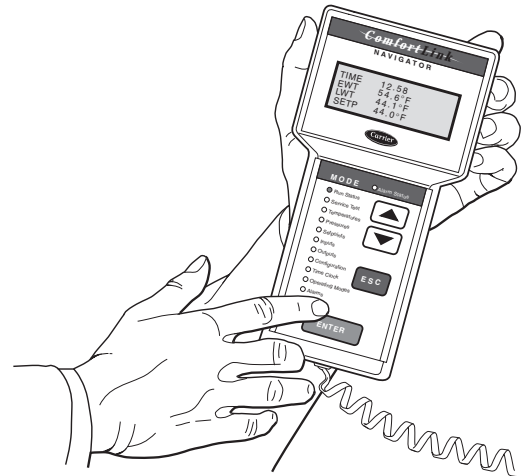

FITS THROUGH STANDARD DOORWAY

TWIN-SCREW COMPRESSOR DESIGN

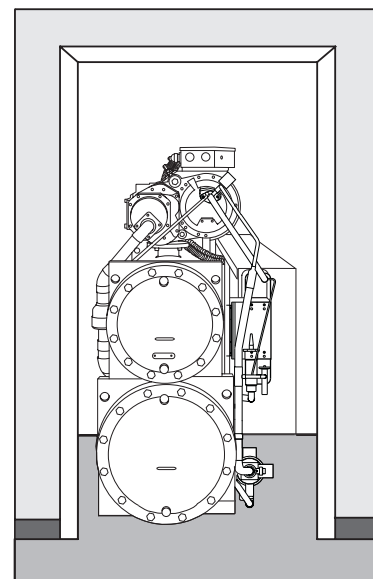
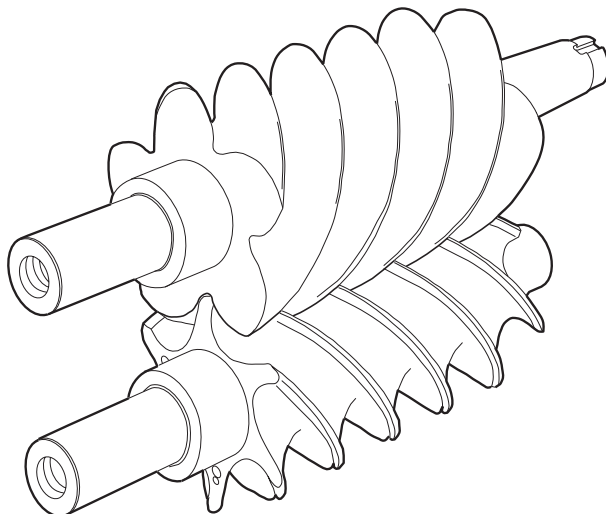
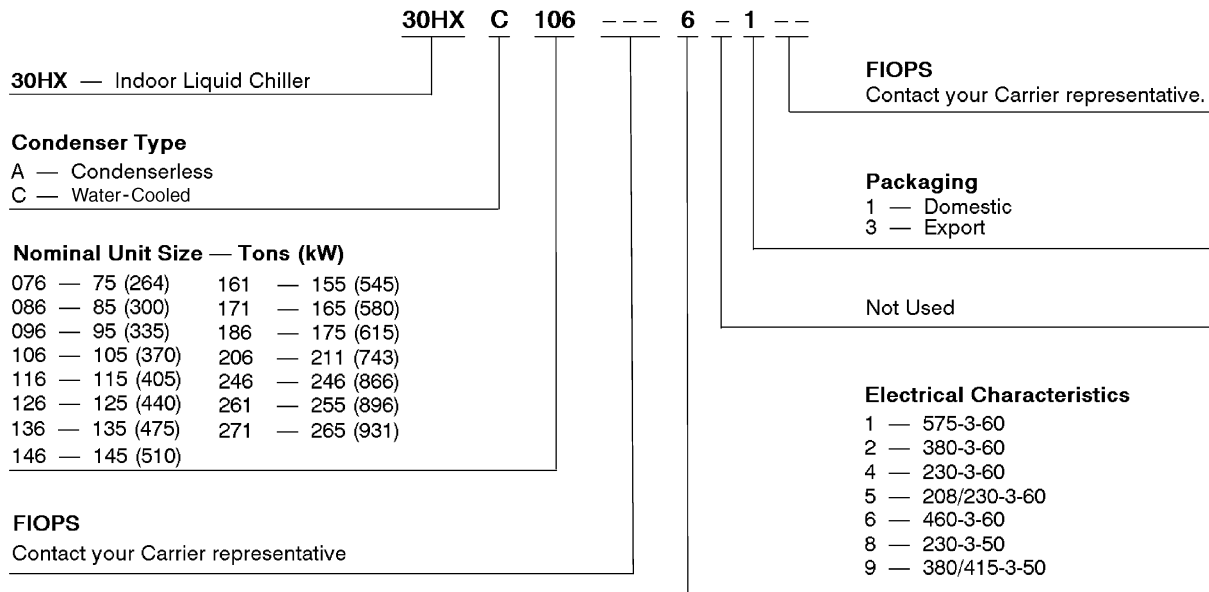

Table of contents



Features/Benefits 1,2
 Model Number Nomenclature 3
 ARI Capacity Ratings 4,5
 Physical Data 6-9
 Options and Accessories 10
 Dimensions 11-20
 Application Data 21-29
 Selection Procedure 30
 Performance Data 31-56
 Typical Piping and Wiring 57,58
 Electrical Data 59-70
 Controls 71
 Guide Specifications 72-74

Model number nomenclature



LEGEND

FIOPS — Factory-Installed Options

Quality Assurance



ARI* capacity ratings



30HXC WATER-COOLED CHILLER ARI RATINGS (60 Hz ONLY)

UNIT SIZE 30HXC	CAPACITY		INPUT POWER (kW)	COOLER FLOW		COOLER PRESSURE DROP		CONDENSER FLOW		CONDENSER PRESSURE DROP		FULL-LOAD EFFICIENCY (kW/Ton)	IPLV† (kW/Ton)
	Tons	Output kW		GPM	L/s	Ft of Water	kPa	GPM	L/S	Ft of Water	kPa		
076	75.4	265.2	53.7	181.0	11.4	12.6	37.7	226.2	14.3	8.0	23.9	0.712	0.512
086	83.1	292.3	60.4	199.4	12.6	15.1	44.9	249.3	15.7	9.6	28.6	0.727	0.523
096	94.0	330.5	67.0	225.5	14.2	14.9	44.6	281.9	17.8	9.9	29.4	0.713	0.513
106	104.3	366.8	75.3	250.3	15.8	13.4	40.1	312.9	19.7	12.0	35.7	0.722	0.521
116	113.6	399.4	79.9	272.6	17.2	11.7	34.9	340.7	21.5	15.3	45.5	0.703	0.509
126	123.0	432.6	86.8	295.2	18.6	13.5	40.3	369.0	23.3	17.7	52.7	0.706	0.509
136	136.5	479.9	97.0	327.5	20.7	12.8	38.3	409.4	25.8	16.7	49.9	0.711	0.527
146	145.9	513.2	105.1	350.2	22.1	14.5	43.3	437.8	27.6	19.0	56.5	0.720	0.533
161	156.5	550.6	111.7	375.7	23.7	12.0	35.7	469.6	29.6	19.4	57.9	0.714	0.520
171	165.9	585.3	118.2	398.1	25.1	13.3	39.6	497.6	31.4	15.9	47.4	0.712	0.538
186	177.2	623.1	126.7	426.2	26.8	12.1	36.2	531.6	33.5	18.0	53.7	0.715	0.562
206	211.6	744.0	146.4	507.7	32.0	12.8	38.2	634.7	40.0	19.0	56.7	0.692	0.510
246	248.6	874.1	172.4	596.5	37.6	14.1	42.1	745.7	47.0	20.1	59.9	0.693	0.522
261	257.2	904.6	180.5	617.3	38.9	15.0	44.8	771.6	48.7	21.4	63.9	0.702	0.523
271	267.4	940.3	189.5	641.7	40.5	16.1	48.0	802.1	50.6	23.0	68.7	0.709	0.525

LEGEND

IPLV — Integrated Part-Load Value

*Air Conditioning and Refrigeration Institute (U.S.A.).

†IPLV shown is the lower of Sequence A or Sequence B unloading.

NOTES:

- Rated (60 Hz only) in accordance with ARI Standard 550/590-98 at standard rating conditions.
- Standard rating conditions are as follows:
Cooler Conditions:
Leaving Water Temperature: 44 F (6.7 C)
Flow: 2.4 gpm per ton (0.043 L/s per kW)
Condenser Conditions:
Entering Water temperature: 85 F (29.4 C)
Flow: 3.0 gpm per ton (0.054 L/s per kW)
Fouling Factor (Cooler):
0.00010 hr x sq ft x F per Btuh (0.000018 m² x K per W)
Fouling Factor (Condenser):
0.00025 hr x sq ft x F per Btuh (0.000044 m² x K per W)

- IPLV is a single number part-load efficiency value calculated from the system full-load efficiency values and corrected for a typical building air-conditioning application.
- All data in this table is rated (60 Hz only) in accordance with ARI Standard 550/590-98 as represented in the ECOLOGIC™ Chiller Selection Program (E-Cat) version 2.80.
- Contact Carrier for custom ratings.



Rated in accordance with
ARI Standard 550/590-98.

60 Hz only





30HXA CONDENSERLESS CHILLER RATINGS (60 Hz ONLY)

UNIT SIZE 30HXA	CAPACITY		INPUT POWER (kW)	COOLER FLOW		COOLER PRESSURE DROP		FULL-LOAD EFFICIENCY (kW/Ton)
	Tons	Output kW		GPM	L/s	Ft of Water	kPa	
076	67.7	237.9	76.2	162.4	10.2	10.4	31.1	1.127
086	76.0	267.2	84.5	182.3	11.5	12.8	38.2	1.112
096	85.8	301.9	95.1	206.0	13.0	12.6	37.7	1.108
106	96.9	340.9	106.9	232.7	14.7	11.8	35.1	1.103
116	104.9	368.9	115.0	251.8	15.9	10.1	30.3	1.097
126	113.9	400.6	125.3	273.4	17.2	11.8	35.1	1.101
136	127.0	446.5	138.5	304.7	19.2	11.3	33.7	1.091
146	137.2	482.5	150.0	329.3	20.8	13.0	38.7	1.094
161	147.3	518.1	159.9	353.6	22.3	10.7	32.0	1.086
171	159.0	559.3	173.8	381.7	24.1	12.3	36.7	1.093
186	174.3	612.8	192.7	418.2	26.4	11.8	35.1	1.106
206	198.5	698.2	216.4	476.5	30.1	11.4	34.1	1.090
246	231.9	815.4	252.4	556.5	35.1	12.5	37.2	1.089
261	244.1	858.6	267.5	585.9	37.0	13.7	40.8	1.096
271	257.9	907.0	283.9	619.0	39.1	15.1	45.0	1.101

NOTES:

- Rated (60 Hz only) in accordance with ARI Standard 550/590-98 at standard rating conditions.
- Standard rating conditions are as follows:
Cooler Conditions:
Leaving Water Temperature: 44 F (6.7 C)
Flow: 2.4 gpm per ton (0.043 L/s per kW)
Saturated Discharge Temperature: 125 F (52 C)

Fouling Factor (Cooler):

0.00010 hr x sq ft x F per Btuh (0.000018 m² x K per W)

- All data in this table is rated (60 Hz only) in accordance with ARI Standard 550/590-98 as represented in the ECOLOGIC™ Chiller Selection Program (E-Cat) version 2.80.
- Contact Carrier for custom ratings.



09DK CONDENSER RATINGS (60 Hz ONLY)

UNIT SIZE 09DK	HP	TONS	BTUH	BTUH/HP
044	3.0	56.2	674,400	224,800
054	4.0	65.8	789,600	197,400
074	6.0	95.4	1,144,800	190,800
084	6.0	103.5	1,242,000	207,000
094	6.0	116.3	1,395,600	232,600

NOTE: Rated in accordance with ARI standard 460-2000 at standard rating conditions.

- 125 F (52 C) Condensing Temperature
- R-22 Test Fluid
- 190 F (88 C) Entering Gas Temperature
- 15° F (8.3° C) Subcooling
- 95 F (35 C) Entering Dry Bulb Temperature



Physical data



ENGLISH

UNIT SIZE 30HX	076	086	096	106	116	126	136	146
UNIT OPERATING WEIGHT (lb)								
Water-Cooled (HXC)	5700	5723	5855	6177	6415	6465	6688	6718
Condenserless (HXA)	4717	4744	4835	5151	5163	5205	5309	5333
COMPRESSORS	Semi-Hermetic, Twin Screw							
Quantity	2	2	2	2	2	2	2	2
Nominal Capacity per Compressor (tons)	39/39	46/39	56/39	66/39	66/46	66/56	80/56	80/66
Economizer	No	No	No	No	No	No	No	No
No. Capacity Steps								
Standard	6	6	6	6	6	6	6	6
Optional (maximum)	8	8	8	8	8	8	8	8
Minimum Step Capacity (%)								
Standard	20	20	20	20	20	20	20	20
Optional	10	10	10	10	10	10	10	10
REFRIGERANT	R-134a							
Charge* (lb) Circuit A/Circuit B	75/75	76/75	94/70	110/70	112/89	112/89	124/89	119/100
COOLER	Shell and Tube with Enhanced Copper Tubes							
Part No. 10HX400-	401	401	402	408	406	406	405	405
Net Fluid Volume (gal)	17.0	17.0	19.0	22.6	21.4	21.4	24.0	24.0
Maximum Refrigerant Pressure (psig)	220	220	220	220	220	220	220	220
Maximum Water-Side Pressure (psig)	300	300	300	300	300	300	300	300
Water Connections								
Inlet and Outlet (in.) (Standard Pass)	4	4	4	5	5	5	5	5
Drain (in. NPT) (Standard Pass)	3/8	3/8	3/8	3/8	3/8	3/8	3/8	3/8
Relief Valve								
Connection (in. NPTF)	3/4	3/4	3/4	3/4	3/4	3/4	3/4	3/4
Flow Capacity (lb air/min)	31.7	31.7	31.7	31.7	31.7	31.7	31.7	31.7
Relief Setting (psig)	220	220	220	220	220	220	220	220
Standard Number of Passes	3	3	3	3	2	2	2	2
30HXA OIL SEPARATOR								
Part No. 09RX400-	217	217	216	216	215	215	215	215
Maximum Refrigerant Pressure (psig)	320	320	320	320	320	320	320	320
Refrigerant Connections (in.)								
Discharge Circuit A/B	2 1/8/2 1/8	2 1/8/2 1/8	2 1/8/2 1/8	2 1/8/2 1/8	2 1/8/2 1/8	2 1/8/2 1/8	2 1/8/2 1/8	2 1/8/2 1/8
Liquid Circuit A/B	1 1/8/1 1/8	1 1/8/1 1/8	1 1/8/1 1/8	1 1/8/1 1/8	1 1/8/1 1/8	1 1/8/1 1/8	1 1/8/1 1/8	1 1/8/1 1/8
Relief Valve								
Connection (in. SAE Flare)	5/8	5/8	5/8	5/8	5/8	5/8	5/8	5/8
Flow Capacity (lb air/min)	21.6	21.6	21.6	21.6	21.6	21.6	21.6	21.6
Relief Setting (psig)	320	320	320	320	320	320	320	320
CONDENSER (HXC)	Shell and Tube with Enhanced Copper Tubes							
Part No. 09RX400-	257	257	258	258	259	259	260	260
Net Fluid Volume (gal)	16.8	16.8	18.3	18.3	23.9	23.9	27.5	27.5
Maximum Refrigerant Pressure (psig)	220	220	220	220	220	220	220	220
Maximum Water-Side Pressure (psig)	300	300	300	300	300	300	300	300
Water Connections (in.)								
Inlet and Outlet (Standard Pass)	5	5	5	5	5	5	5	5
Drain (NPT) (Standard Pass)	3/8	3/8	3/8	3/8	3/8	3/8	3/8	3/8
Relief Valve								
Connection (in. NPTF)	3/4	3/4	3/4	3/4	3/4	3/4	3/4	3/4
Flow Capacity (lb air/min)	31.7	31.7	31.7	31.7	31.7	31.7	31.7	31.7
Relief Setting (psig)	220	220	220	220	220	220	220	220
Standard Number of Passes	2	2	2	2	2	2	2	2
DISCHARGE LINE†								
Relief Valve								
Connection (in. SAE Flare)	3/8	3/8	3/8	3/8	3/8	3/8	3/8	3/8
Flow Capacity (lb air/min)	6.3	6.3	6.3	6.3	6.3	6.3	6.3	6.3
Setting (psig)	350	350	350	350	350	350	350	350

LEGEND

NPTF — National Pipe Thread Female
SAE — Society of Automotive Engineers

*Charges listed are for 30HXC units. The 30HXA units are shipped with a holding charge only. To determine the refrigerant charge requirements for 30HXA units see the System Refrigerant Charge for Start-Up table in the Application Data on page 28.

†Only on units with factory-installed suction service valves.



ENGLISH (cont)

UNIT SIZE 30HX	161	171	186	206	246	261	271
UNIT OPERATING WEIGHT (lb)							
Water-Cooled (HXC)	7452	7660	7854	10,581	10,969	10,992	11,029
Condenserless (HXA)	5752	5777	5946	7,485	7,621	7,621	7,621
COMPRESSORS	Semi-Hermetic, Twin Screw						
Quantity	2	2	2	3	3	3	3
Nominal Capacity per Compressor (tons)	80/56	66/80	80/80	66/39/80	80/56/80	80/66/80	80/80/80
Economizer	Yes	Yes	Yes	Yes	Yes	Yes	Yes
No. Capacity Steps							
Standard	6	6	6	8	8	8	8
Optional (maximum)	8	8	8	11	11	11	11
Minimum Step Capacity (%)							
Standard	20	20	20	13	13	13	13
Optional	10	10	10	7	7	7	7
REFRIGERANT				R-134a			
Charge* (lb) Circuit A/Circuit B	157/110	119/140	135/135	220/135	220/135	220/135	220/135
COOLER TYPE	Shell and Tube with Enhanced Copper Tubes						
Part No. 10HX400-	601	611	621	631	632	632	632
Net Fluid Volume (gal)	28.5	28.5	33.4	43.1	47.2	47.2	47.2
Maximum Refrigerant Pressure (psig)	220	220	220	220	220	220	220
Maximum Water-Side Pressure (psig)	300	300	300	300	300	300	300
Water Connections							
Inlet and Outlet (in.) (Standard Pass)	5	5	5	6	6	6	6
Drain (NPT) (Standard Pass)	3/8	3/8	3/8	3/8	3/8	3/8	3/8
Relief Valve							
Connection (in. NPTF)	3/4	3/4	3/4	3/4	3/4	3/4	3/4
Flow Capacity (lb air/min)	31.7	31.7	31.7	31.7	31.7	31.7	31.7
Relief Setting (psig)	220	220	220	220	220	220	220
Standard Number of Passes	2	2	2	2	2	2	2
30HXA OIL SEPARATOR							
Part No. 09RX400-	215	214	214	213	213	213	213
Maximum Refrigerant Pressure (psig)	320	320	320	320	320	320	320
Refrigerant Connections (in.)							
Discharge Circuit A/B	2 1/8/2 1/8	2 1/8/2 1/8	2 1/8/2 1/8	2 1/8/2 1/8	2 1/8/2 1/8	2 1/8/2 1/8	2 1/8/2 1/8
Liquid Circuit A/B	1 3/8/1 3/8	1 3/8/1 3/8	1 3/8/1 3/8	1 5/8/1 3/8	1 5/8/1 3/8	1 5/8/1 3/8	1 5/8/1 3/8
Relief Valve							
Connection (in. SAE Flare)	5/8	5/8	5/8	5/8	5/8	5/8	5/8
Flow Capacity (lb air/min)	21.6	21.6	21.6	21.6	21.6	21.6	21.6
Relief Setting (psig)	320	320	320	320	320	320	320
CONDENSER (HXC)	Shell and Tube with Enhanced Copper Tubes						
Part No. 09RX400-	261	262	262	263	264	264	264
Net Fluid Volume (gal)	30.6	37.6	37.6	47.6	55.1	55.1	55.1
Maximum Refrigerant Pressure (psig)	220	220	220	220	220	220	220
Maximum Water-Side Pressure (psig)	300	300	300	300	300	300	300
Water Connections (in.)				Victaulic Type Connection			
Inlet and Outlet (Standard Pass)	6	6	6	8	8	8	8
Drain (NPT) (Standard Pass)	3/8	3/8	3/8	3/8	3/8	3/8	3/8
Relief Valve							
Connection (in. NPTF)	3/4	3/4	3/4	3/4	3/4	3/4	3/4
Flow Capacity (lb air/min)	31.7	31.7	31.7	31.7	31.7	31.7	31.7
Relief Setting (psig)	220	220	220	220	220	220	220
Standard Number of Passes	2	2	2	2	2	2	2
DISCHARGE LINE†							
Relief Valve							
Connection (in. SAE Flare)	3/8	3/8	3/8	3/8	3/8	3/8	3/8
Flow Capacity (lb air/min)	6.3	6.3	6.3	6.3	6.3	6.3	6.3
Setting (psig)	350	350	350	350	350	350	350

LEGEND

NPTF — National Pipe Thread Female
SAE — Society of Automotive Engineers

*Charges listed are for 30HXC units. The 30HXA units are shipped with a holding charge only. To determine the refrigerant charge requirements for 30HXA units see the System Refrigerant Charge for Start-Up table in the Application Data on page 28.
†Only on units with factory-installed suction service valves.

Physical data (cont)



SI

UNIT SIZE 30HX	076	086	096	106	116	126	136	146
UNIT OPERATING WEIGHT (kg)								
Water-Cooled (HXC)	2586	2597	2657	2803	2911	2933	3034	3048
Condenserless (HXA)	2140	2152	2194	2337	2342	2362	2408	2420
COMPRESSORS	Semi-Hermetic, Twin Screw							
Quantity	2	2	2	2	2	2	2	2
Nominal Capacity per Compressor (kW)	137/137	162/137	197/137	232/137	232/137	232/197	281/197	281/232
Economizer	No	No	No	No	No	No	No	No
No. Capacity Steps								
Standard	6	6	6	6	6	6	6	6
Optional (maximum)	8	8	8	8	8	8	8	8
Minimum Step Capacity (%)								
Standard	20	20	20	20	20	20	20	20
Optional	10	10	10	10	10	10	10	10
REFRIGERANT	R-134a							
Charge* (kg) Circuit A/Circuit B	34.1/34.1	34.5/34.1	42.7/31.8	49.9/31.8	50.8/40.4	50.8/40.4	56.3/40.4	54.0/45.4
COOLER	Shell and Tube with Enhanced Copper Tubes							
Part No. 10HX400-	401	401	402	408	406	406	405	405
Net Fluid Volume (L)	64.3	64.3	71.9	85.5	81.0	81.0	90.8	90.8
Maximum Refrigerant Pressure (kPa)	1517	1517	1517	1517	1517	1517	1517	1517
Maximum Water-Side Pressure (kPa)	2068	2068	2068	2068	2068	2068	2068	2068
Water Connections								
Inlet and Outlet (in.) (Standard Pass)	4	4	4	5	5	5	5	5
Drain (NPT) (Standard Pass)	3/8	3/8	3/8	3/8	3/8	3/8	3/8	3/8
Relief Valve								
Connection (in. NPTF)	3/4	3/4	3/4	3/4	3/4	3/4	3/4	3/4
Flow Capacity (kg air/min)	14.38	14.38	14.38	14.38	14.38	14.38	14.38	14.38
Relief Setting (kPa)	1517	1517	1517	1517	1517	1517	1517	1517
Standard Number of Passes	3	3	3	3	2	2	2	2
30HXA OIL SEPARATOR								
Part No. 09RX400-	217	217	216	216	215	215	215	215
Maximum Refrigerant Pressure (kPa)	2205	2205	2205	2205	2205	2205	2205	2205
Refrigerant Connections (in.)								
Discharge A/B	2 1/8/2 1/8	2 1/8/2 1/8	2 1/8/2 1/8	2 1/8/2 1/8	2 1/8/2 1/8	2 1/8/2 1/8	2 1/8/2 1/8	2 1/8/2 1/8
Liquid A/B	1 1/8/2 1/8	1 1/8/1 1/8	1 1/8/1 1/8	1 1/8/1 1/8	1 1/8/1 1/8	1 1/8/1 1/8	1 1/8/1 1/8	1 1/8/1 1/8
Relief Valve								
Connection (in. SAE Flare)	5/8	5/8	5/8	5/8	5/8	5/8	5/8	5/8
Flow Capacity (kg air/min)	9.80	9.80	9.80	9.80	9.80	9.80	9.80	9.80
Relief Setting (kPa)	2206	2206	2206	2206	2206	2206	2206	2206
CONDENSER (HXC)	Shell and Tube with Enhanced Copper Tubes							
Part No. 09RX400-	257	257	258	258	259	259	260	260
Net Fluid Volume (L)	63.6	63.6	69.3	69.3	90.5	90.5	104.1	104.1
Maximum Refrigerant Pressure (kPa)	1517	1517	1517	1517	1517	1517	1517	1517
Maximum Water-Side Pressure (kPa)	2068	2068	2068	2068	2068	2068	2068	2068
Water Connections (in.)								
Inlet and Outlet (Standard Pass)	5	5	5	5	5	5	5	5
Drain (NPT) (Standard Pass)	3/8	3/8	3/8	3/8	3/8	3/8	3/8	3/8
Relief Valve								
Connection (in. NPTF)	3/4	3/4	3/4	3/4	3/4	3/4	3/4	3/4
Flow Capacity (kg air/min)	14.38	14.38	14.38	14.38	14.38	14.38	14.38	14.38
Relief Setting (kPa)	1517	1517	1517	1517	1517	1517	1517	1517
Standard Number of Passes	2	2	2	2	2	2	2	2
DISCHARGE LINE†								
Relief Valve								
Connection (in. SAE Flare)	3/8	3/8	3/8	3/8	3/8	3/8	3/8	3/8
Flow Capacity (kg air/min)	2.9	2.9	2.9	2.9	2.9	2.9	2.9	2.9
Relief Pressure (kPa)	2413	2413	2413	2413	2413	2413	2413	2413

LEGEND

NPTF — National Pipe Thread Female
SAE — Society of Automotive Engineers

*Charges listed are for 30HXC units. The 30HXA units are shipped with a holding charge only. To determine the refrigerant charge requirements for 30HXA units see the System Refrigerant Charge for Start-Up table in the Application Data on page 28.

†Only on units with factory-installed suction service valves.



SI (cont)

UNIT SIZE 30HX	161	171	186	206	246	261	271
UNIT OPERATING WEIGHT (kg)							
Water-Cooled (HXC)	3381	3475	3564	4799	4976	4986	5003
Condenserless (HXA)	2610	2621	2698	3395	3457	3457	3457
COMPRESSORS	Semi-Hermetic, Twin Screw						
Quantity	2	2	2	3	3	3	3
Nominal Capacity per Compressor (kW)	281/197	232/281	281/281	232/137/281	281/197/281	281/232/281	281/281/281
Economizer	Yes	Yes	Yes	Yes	Yes	Yes	Yes
No. Capacity Steps							
Standard	6	6	6	8	8	8	8
Optional (maximum)	8	8	8	11	11	11	11
Minimum Step Capacity (%)							
Standard	20	20	20	13	13	13	13
Optional	10	10	10	7	7	7	7
REFRIGERANT	R-134a						
Charge* (kg) Circuit A/Circuit B	71.3/49.9	54.0/63.6	61.3/61.3	90.8/61.3	99.9/61.3	99.9/61.3	99.9/61.3
COOLER	Shell and Tube with Enhanced Copper Tubes						
Part No. 10HX400-	601	611	621	631	632	632	632
Net Fluid Volume (L)	107.9	107.9	126.4	163.2	178.7	178.8	178.7
Maximum Refrigerant Pressure (kPa)	1517	1517	1517	1517	1517	1517	1517
Maximum Water-Side Pressure (kPa)	2068	2068	2068	2068	2068	2068	2068
Water Connections							
Inlet and Outlet (in.) (Standard Pass)	5	5	5	6	6	6	6
Drain (NPT) (Standard Pass)	3/8	3/8	3/8	3/8	3/8	3/8	3/8
Relief Valve							
Connection (in. NPTF)	3/4	3/4	3/4	3/4	3/4	3/4	3/4
Flow Capacity (kg air/min)	14.28	14.38	14.38	14.38	14.38	14.38	14.38
Relief Setting (kPa)	1517	1517	1517	1517	1517	1517	1517
Standard Number of Passes	2	2	2	2	2	2	2
30HXA OIL SEPARATOR							
Part No. 09RX400-	215	214	214	213	213	213	213
Maximum Refrigerant Pressure (kPa)	2205	2205	2205	2205	2205	2205	2205
Refrigerant Connections (in.)							
Discharge A/B	2 1/8/2 1/8	2 1/8/2 1/8	2 1/8/2 1/8	2 1/8/2 1/8	2 1/8/2 1/8	2 1/8/2 1/8	2 1/8/2 1/8
Liquid A/B	1 3/8/1 3/8	1 3/8/1 3/8	1 3/8/1 3/8	1 5/8/1 3/8	1 5/8/1 3/8	1 5/8/1 3/8	1 5/8/1 3/8
Relief Valve							
Connection (in. SAE Flare)	5/8	5/8	5/8	5/8	5/8	5/8	5/8
Flow Capacity (kg air/min)	9.80	9.80	9.80	9.80	9.80	9.80	9.80
Relief Setting (kPa)	2206	2206	2206	2206	2206	2206	2206
CONDENSER (HXC)	Shell and Tube with Enhanced Copper Tubes						
Part No. 09RX400-	261	262	262	263	264	264	264
Net Fluid Volume (L)	115.8	142.3	142.3	177.9	208.6	208.6	208.6
Maximum Refrigerant Pressure (kPa)	1517	1517	1517	1517	1517	1517	1517
Maximum Water-Side Pressure (kPa)	2068	2068	2068	2068	2068	2068	2068
Water Connections (in.)							
Inlet and Outlet (Standard Pass)	6	6	6	8	8	8	8
Drain (NPT) (Standard Pass)	3/8	3/8	3/8	3/8	3/8	3/8	3/8
Relief Valve							
Connection (in. NPTF)	3/4	3/4	3/4	3/4	3/4	3/4	3/4
Flow Capacity (kg air/min)	14.38	14.38	14.38	14.38	14.38	14.38	14.38
Relief Setting (kPa)	1517	1517	1517	1517	1517	1517	1517
Standard Number of Passes	2	2	2	2	2	2	2
DISCHARGE LINE†							
Relief Valve							
Connection (in. SAE Flare)	3/8	3/8	3/8	3/8	3/8	3/8	3/8
Flow Capacity (kg air/min)	2.9	2.9	2.9	2.9	2.9	2.9	2.9
Relief Pressure (kPa)	2413	2413	2413	2413	2413	2413	2413

LEGEND

NPTF — National Pipe Thread Female
 SAE — Society of Automotive Engineers

*Charges listed are for 30HXC units. The 30HXA units are shipped with a holding charge only. To determine the refrigerant charge requirements for 30HXA units see the System Refrigerant Charge for Start-Up table in the Application Data on page 28.

†Only on units with factory-installed suction service valves.

Options and accessories



ITEM	FACTORY-INSTALLED OPTION	FIELD-INSTALLED ACCESSORY
Wye-Delta Start	X	
Brine	X	
Minus-One-Pass Cooler Head	X	
Plus-One-Pass Cooler Head	X	
Control Power Transformer		X
Minimum Load Control	X	X
Sound Reduction Enclosure		X
Vibration Isolation		X
Temperature Reset Sensor		X
Chillervisor™ System Manager III		X
Cooler Head Insulation		X
Suction Service Valves	X	
Energy Management Module	X	X

Factory-installed options

Wye-delta start — Generally, Wye-delta start is not required when using multiple compressors since the starting current is generally less than with one larger compressor using Wye-delta start. Wye-delta start is standard on 208/230 v, 60 Hz, 230 v, 60 Hz, and 230 v, 50 Hz units. It is available as a factory-installed option for all other unit voltages.

Brine — The brine option permits supply liquid temperatures to be set below 40 F (4.4 C). Refrigeration circuit components, such as the expansion device, are modified at the factory to correct for the lower refrigeration flow rates. Special installation requirements apply to brine units. See Cooler and Water-Cooled Condenser Freeze Protection section, page 23.

Minus-One-Pass cooler — This factory-installed option reduces pressure drop for high flow applications and/or provides same end inlet and outlet for 076-106 sizes, or opposite end inlet and outlet on 116-271 sizes.

Plus-One-Pass cooler — This factory-installed option improves low temperature brine performance. See Carrier 30HX electronic catalog for performance data.

Minimum load control — This option allows additional capacity reduction for unit operation below the minimum step of unloading (down to 10% of full load capacity). Minimum load control is also available as a field-installed accessory.

Suction service valves — Standard refrigerant discharge isolation and liquid valves enable service personnel to store the refrigerant charge in the cooler or condenser during servicing. This factory-installed option allows further isolation of the compressor from the cooler vessel.

Energy Management Module (EMM) — The EMM is used for 4 to 20 mA leaving fluid temperature reset, cooling point reset, 4 to 20 mA demand limit and two-step demand limit. Temperature reset lets the unit reset the leaving fluid temperature to a higher temperature during low load conditions. Temperature reset can also be accomplished based on return fluid, outdoor air or space temperature. (The EMM option is not required when using

entering-water, outdoor-air, or space temperature for temperature reset. These types of reset are available with the main board. However, an accessory thermistor is required for outdoor air and/or space temperature reset.) Demand limiting allows the unit capacity to be limited during periods of peak energy usage. Demand limit requires an external 4 to 20 mA signal or a 2-step remote pair of dry contacts. Both the 4 to 20 mA and 2-step demand limit percentage values are adjustable. EMM is also available as a field-installed accessory.

Field-installed accessories

Control power transformer — The transformer is sized to supply the needs of the control circuit, sourcing power from the main unit power connection.

Minimum load control — This accessory allows additional capacity reduction for unit operation below the minimum step of unloading (down to 10% of full load capacity). Minimum load control is also available as a factory-installed option.

Sound reduction enclosure — This kit contains a sound enclosure that covers the entire unit to reduce sound levels.

Vibration isolation — Neoprene isolators are field installed to reduce vibration transmission from the compressor through the floor and into the conditioned space.

Temperature reset sensor — This accessory sensor provides temperature reset capability from either the occupied space or outdoor-air temperature.

NOTE: Temperature reset capability using return temperature is standard.

Chillervisor System Manager III — This control can be used to regulate up to eight 30HXA or 30HXC chillers.

Cooler head insulation — This accessory is designed with flexible, 3/4 in. (19 mm) PVC foam (closed-cell) to insulate the cooler heads to minimize heat loss and head sweating.

Energy Management Module (EMM) is used for 4 to 20 mA leaving fluid temperature reset, cooling point reset, 4 to 20 mA demand limit and two-step demand limit. Temperature reset lets the unit reset the leaving fluid temperature to a higher temperature during low load conditions. Temperature reset can also be accomplished based on return fluid, outdoor air or space temperature. (The EMM option is not required when using entering-water, outdoor-air, or space temperature for temperature reset. These types of reset are available with the main board. However, an accessory thermistor is required for outdoor air and/or space temperature reset.) Demand limiting allows the unit capacity to be limited during periods of peak energy usage. Demand limit requires an external 4 to 20 mA signal or a 2-step remote pair of dry contacts. Both the 4 to 20 mA and 2-step demand limit percentage values are adjustable. EMM is also available as a factory-installed option.

Consult factory for other available options not listed here.

30HXC076-106

NOTES:

- Operating weight includes weight of water and refrigerant.
- Denotes center of gravity.
- Dimensions are in inches (mm).
- Recommended service clearance around machine is 36 in. (914.4 mm).
- Vitaulic nozzles are standard on all models. Flow switch factory installed in cooler outlet vitaulic nozzle.

UNIT	OPERATING WEIGHT - lb (kg)	WGT DISTRIBUTION AT EACH MTG PLATE - lb (kg)						L	E	C	B
		1	2	3	4	5	6				
30HXC076	5700 (2586)	738 (335)	943 (428)	595 (270)	1110 (503)	1418 (643)	896 (406)	65.22 (1657)	32.50 (826)	45.87 (1165)	45.87 (1165)
30HXC086	5723 (2597)	738 (335)	947 (430)	597 (271)	1112 (504)	1427 (647)	902 (409)	65.22 (1657)	32.50 (826)	45.87 (1165)	45.87 (1165)
30HXC096	5855 (2657)	738 (335)	947 (430)	597 (271)	1112 (504)	1447 (656)	1034 (468)	66.86 (1657)	32.50 (826)	45.87 (1165)	45.87 (1165)
30HXC106	6177 (2803)	738 (335)	1028 (466)	744 (337)	1073 (487)	1510 (685)	1092 (495)	67.22 (1707)	33.50 (851)	47.75 (1203)	47.75 (1203)

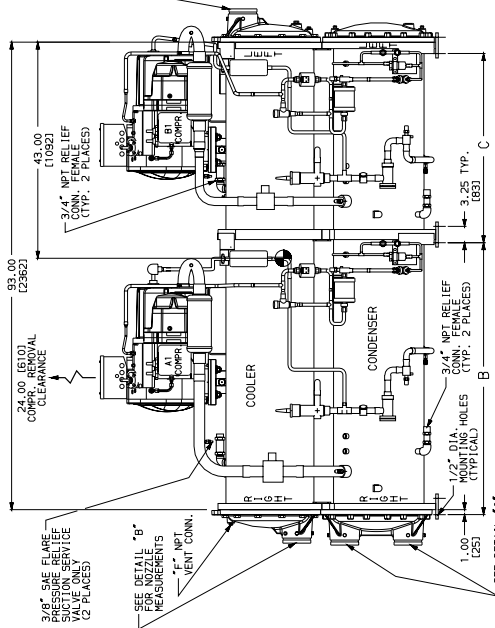
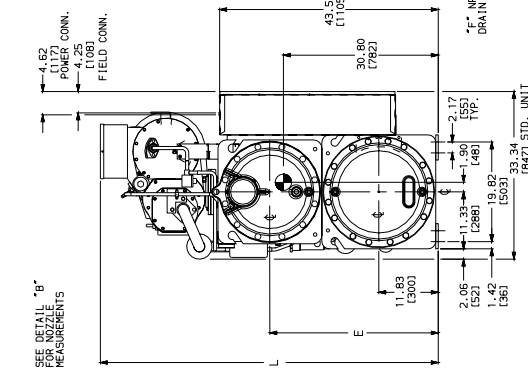
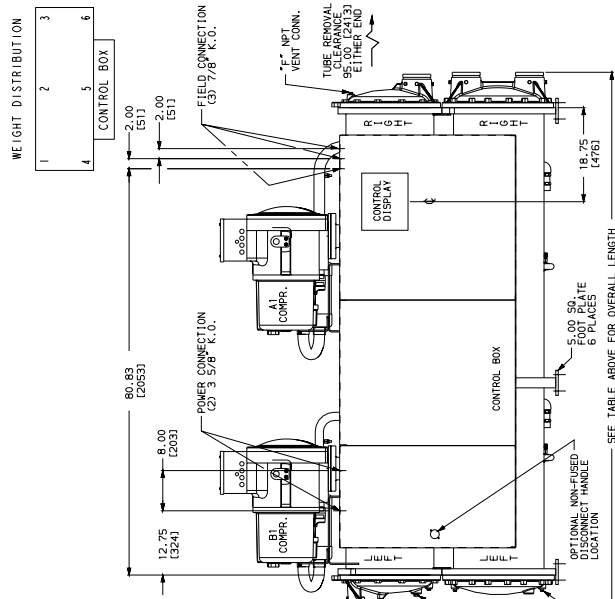

COOLER	CONDENSER	OVERALL LENGTH OVERALL LENGTH
STANDARD COOLER	STANDARD CONDENSER	106.70 (2710)
STANDARD COOLER	MINUS ONE PASS CONDENSER	113.00 (2870)
STANDARD COOLER	PLUS ONE PASS CONDENSER	113.00 (2870)
PLUS ONE PASS COOLER	STANDARD CONDENSER	103.80 (2641)
PLUS ONE PASS COOLER	MINUS ONE PASS CONDENSER	103.80 (2641)
PLUS ONE PASS COOLER	PLUS ONE PASS CONDENSER	113.00 (2870)

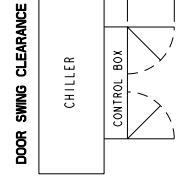
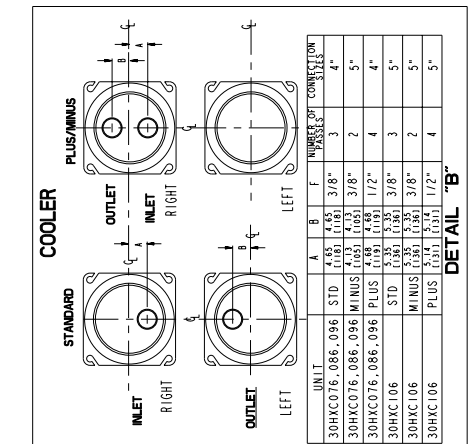
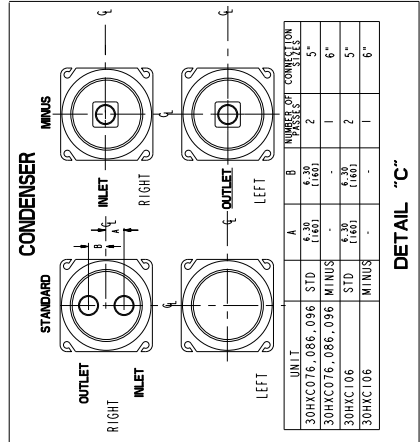



30HXC116-146

NOTES:

- Operating weight includes weight of water and refrigerant.
- Denotes center of gravity.
- Dimensions are in inches (mm).
- Recommended service clearance around machine is 36 in. (914.4 mm).
- Victaulic nozzles are standard on all models. Flow switch factory installed in cooler outlet victaulic nozzle.

UNIT	WGHT DISTRIBUTION AT EACH MTG PLATE - lb (kg)					
	1	2	3	4	5	6
30HXC116	728 (330)	1114 (505)	777 (352)	1053 (478)	1615 (733)	1127 (511)
30HXC126	738 (335)	1127 (511)	780 (354)	1061 (481)	1628 (738)	1131 (513)
30HXC136	688 (311)	1176 (533)	811 (368)	1083 (491)	1689 (766)	1171 (531)
30HXC146	671 (304)	1182 (536)	815 (370)	1085 (492)	1697 (770)	1172 (532)

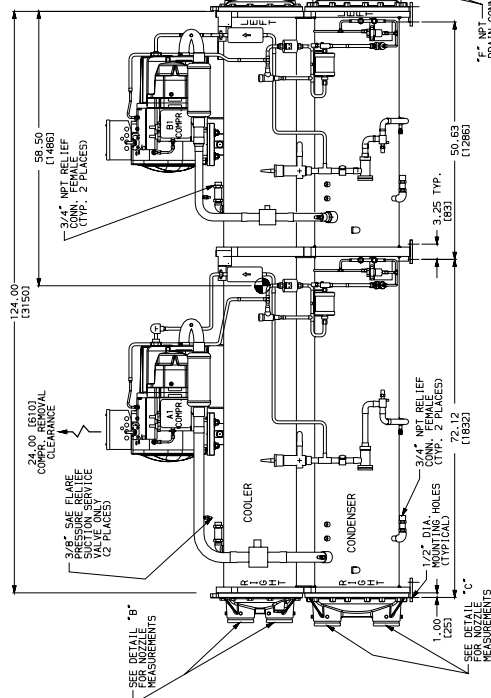
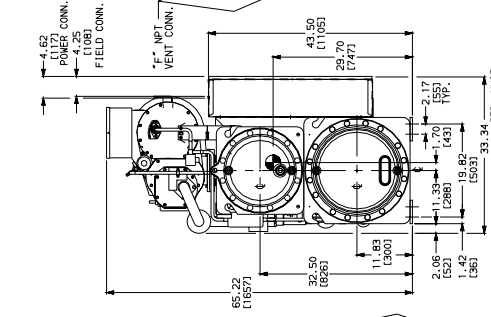
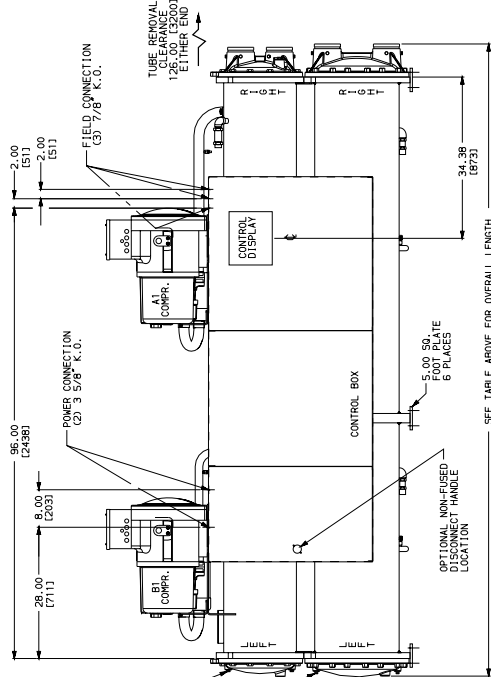
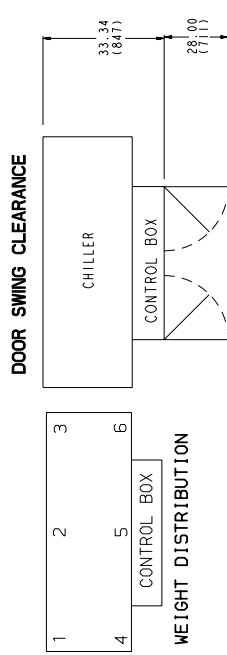

OVERALL LENGTH TABLE	
COOLER	CONDENSER OVERALL LENGTH
STANDARD COOLER	STANDARD CONDENSER (3429)
STANDARD COOLER	MINUS ONE PASS CONDENSER (3658)
PLUS ONE COOLER	STANDARD CONDENSER (3490)
PASS COOLER	MINUS ONE PASS CONDENSER (3658)
MINUS ONE COOLER	STANDARD CONDENSER (3429)
MINUS ONE PASS COOLER	MINUS ONE PASS CONDENSER (3658)

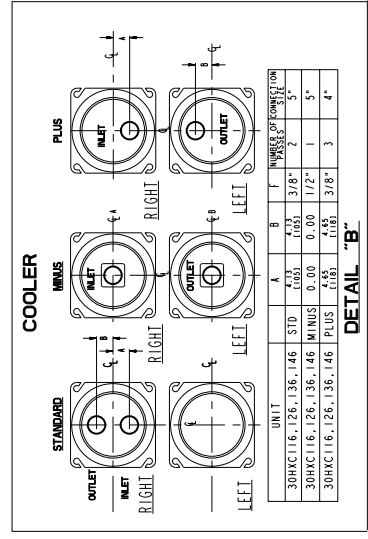
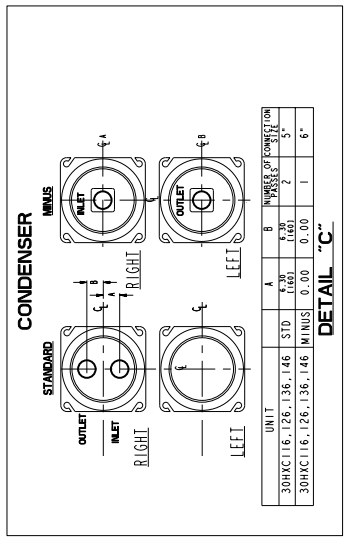

30HXC161-186

NOTES:

- Operating weight includes weight of water and refrigerant.
- Denotes center of gravity.
- Dimensions are in inches (mm).
- Recommended service clearance around machine is 36 in. (914.4 mm)
- Victaulic nozzles are standard on all models. Flow switch factory installed in cooler outlet victaulic nozzle.

UNIT	WGT DISTRIBUTION AT EACH MTG PLATE - lb (kg)					
	1	2	3	4	5	6
30HXC161	7452 (3381)	817 (371)	1272 (577)	908 (412)	1219 (553)	1890 (857)
30HXC171	7660 (3475)	61.37 (27.8)	936 (425)	1318 (598)	1379 (626)	1946 (883)
30HXC186	7854 (3564)	61.37 (27.8)	962 (436)	1361 (617)	1410 (640)	1996 (905)

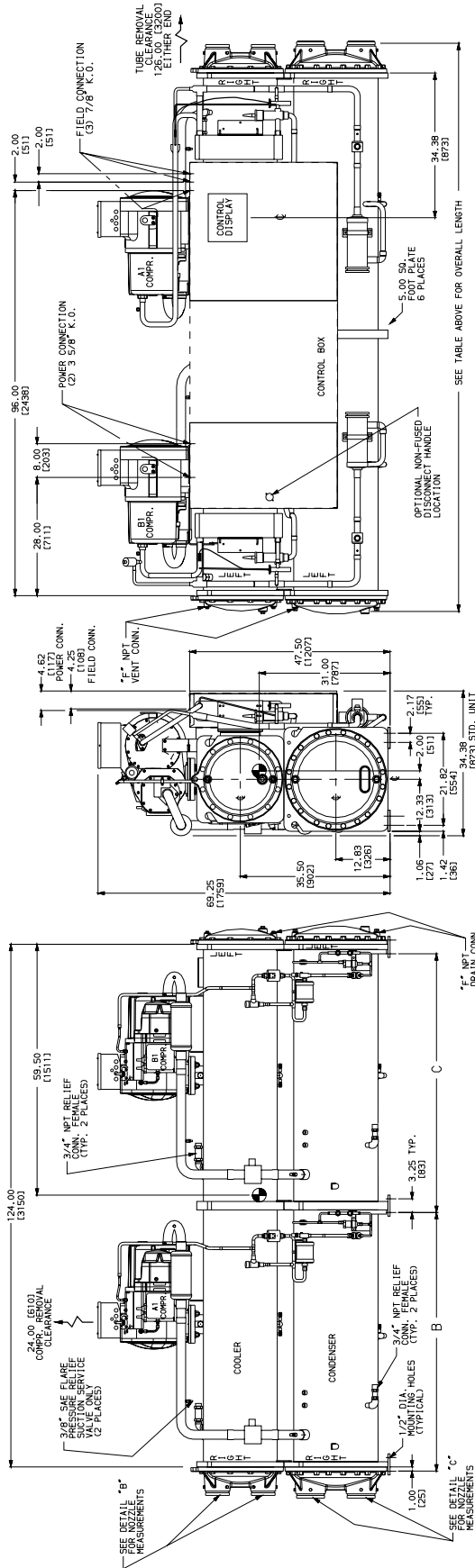
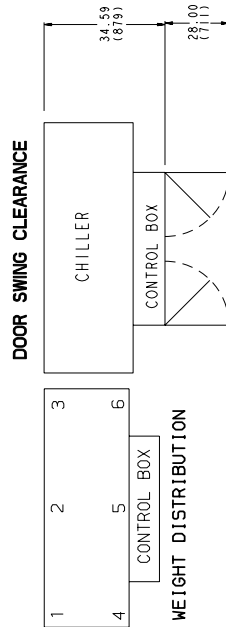

OVERALL LENGTH TABLE	
COOLER	CONDENSER
STANDARD COOLER	STANDARD CONDENSER
MINUS ONE COOLER	MINUS ONE CONDENSER
PLUS ONE COOLER	PLUS ONE CONDENSER
MINUS ONE PLUS ONE COOLER	MINUS ONE PLUS ONE CONDENSER
STANDARD COOLER	STANDARD CONDENSER
MINUS ONE COOLER	MINUS ONE CONDENSER
PLUS ONE COOLER	PLUS ONE CONDENSER
MINUS ONE PLUS ONE COOLER	MINUS ONE PLUS ONE CONDENSER

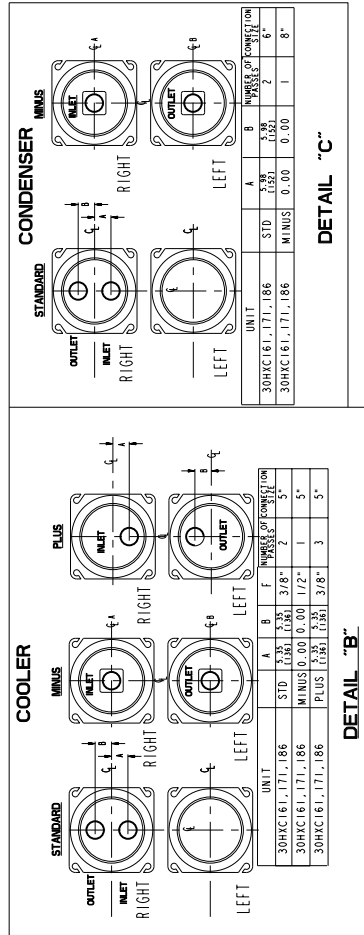

Dimensions (cont)



30HXC206-271

NOTES:

- Operating weight includes weight of water and refrigerant.
- Denotes center of gravity.
- Dimensions are in inches (mm).
- Recommended service clearance around machine is 36 in. (914.4 mm).
- Victaulic nozzles are standard on all models. Flow switch factory installed in cooler outlet victaulic nozzle.

UNIT	OPERATING WEIGHT - lb (kg)	WGT DISTRIBUTION AT EACH MTG PLATE - lb (kg)						
		A	1	2	3	4	5	6
30HXC206	10581 (4799)	33.88 (860)	948 (430)	2406 (1091)	1243 (564)	1201 (545)	3133 (1421)	1650 (748)
30HXC246	10969 (4976)	34.38 (873)	985 (447)	2515 (1141)	1306 (592)	1154 (523)	3276 (1486)	1733 (786)
30HXC261	10992 (4986)	34.38 (873)	985 (447)	2520 (1143)	1311 (595)	1154 (523)	3283 (1489)	1739 (789)
30HXC271	11029 (5003)	34.38 (873)	985 (447)	2529 (1147)	1318 (598)	1154 (523)	3294 (1494)	1749 (793)

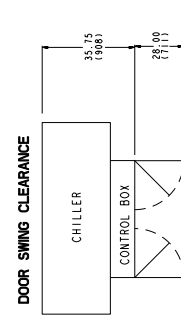
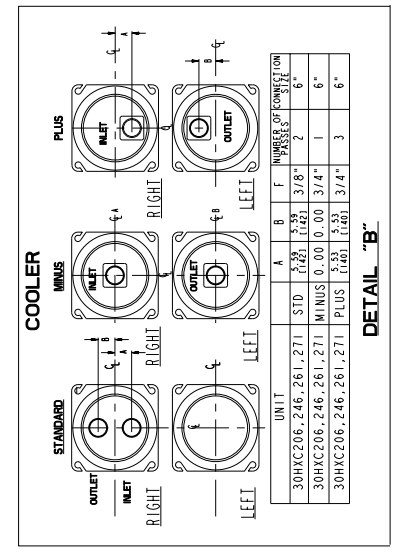
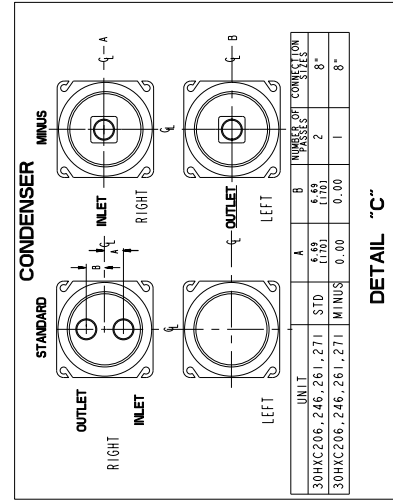
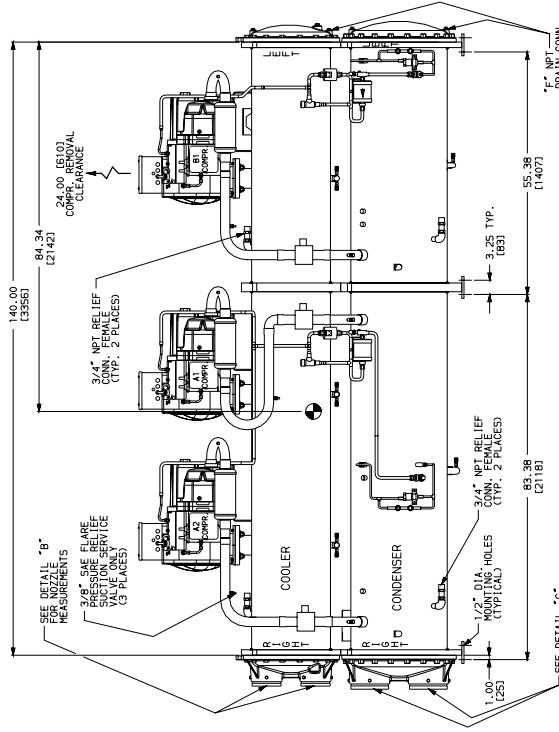
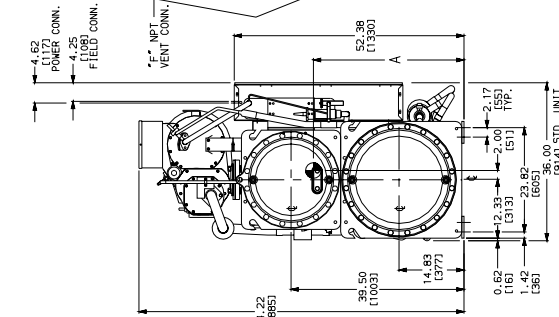
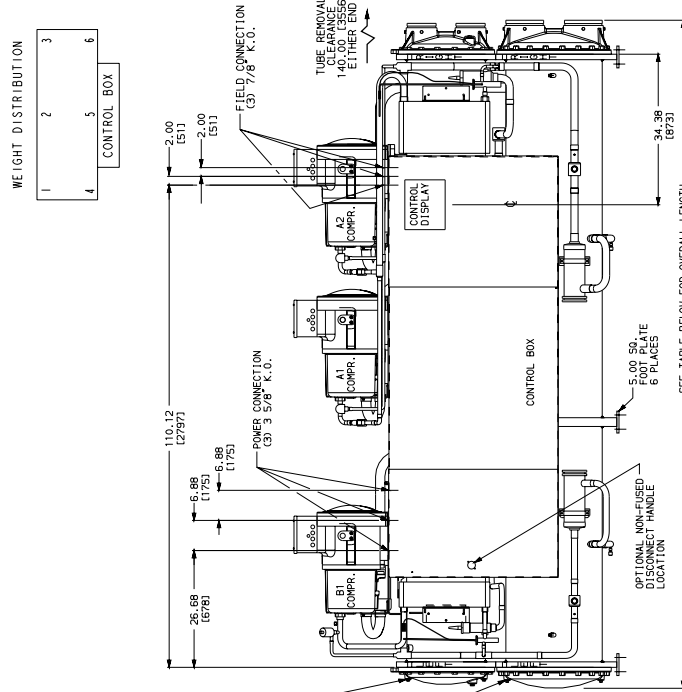

COOLER	CONDENSER	OVERALL LENGTH
STANDARD	CONDENSER	152.54 (3875)
STANDARD	COOLER	138.15 (3508)
STANDARD	PASS CONDENSER	1406.00 (35760)
PLUS ONE	STANDARD CONDENSER	160.00 (4064)
PASS COOLER	CONDENSER	1406.41 (35761)
PLUS ONE	MINUS ONE	160.00 (4064)
PASS COOLER	CONDENSER	1406.41 (35761)
MINUS ONE	STANDARD CONDENSER	160.00 (4064)
MINUS ONE	PASS CONDENSER	1406.41 (35761)
PASS COOLER	CONDENSER	1406.41 (35761)

30HX076-106

UNIT	WGT DISTRIBUTION AT EACH MTG PLATE - lb (kg)					
	1	2	3	4	5	6
30HXA076	4717 (2140)	555 (252)	793 (360)	418 (190)	926 (420)	1326 (601)
30HXA086	4744 (2152)	555 (252)	798 (362)	418 (190)	928 (421)	1340 (608)
30HXA096	4835 (2194)	509 (231)	808 (367)	493 (224)	848 (385)	1350 (612)
30HXA106	5151 (2337)	555 (252)	869 (394)	541 (245)	896 (406)	1410 (640)

OVERALL LENGTH TABLE	
COOLER	OVERALL LENGTH 976, 086, 096 106
STANDARD COOLER	105.68 (2764)
MINUS ONE PASS COOLER	103.28 (2633)
PLUS ONE PASS COOLER	107.00 (2718)

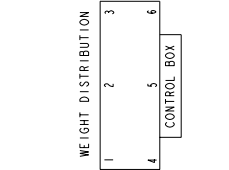
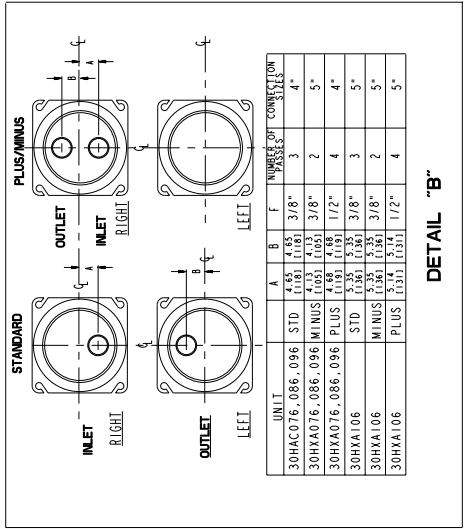
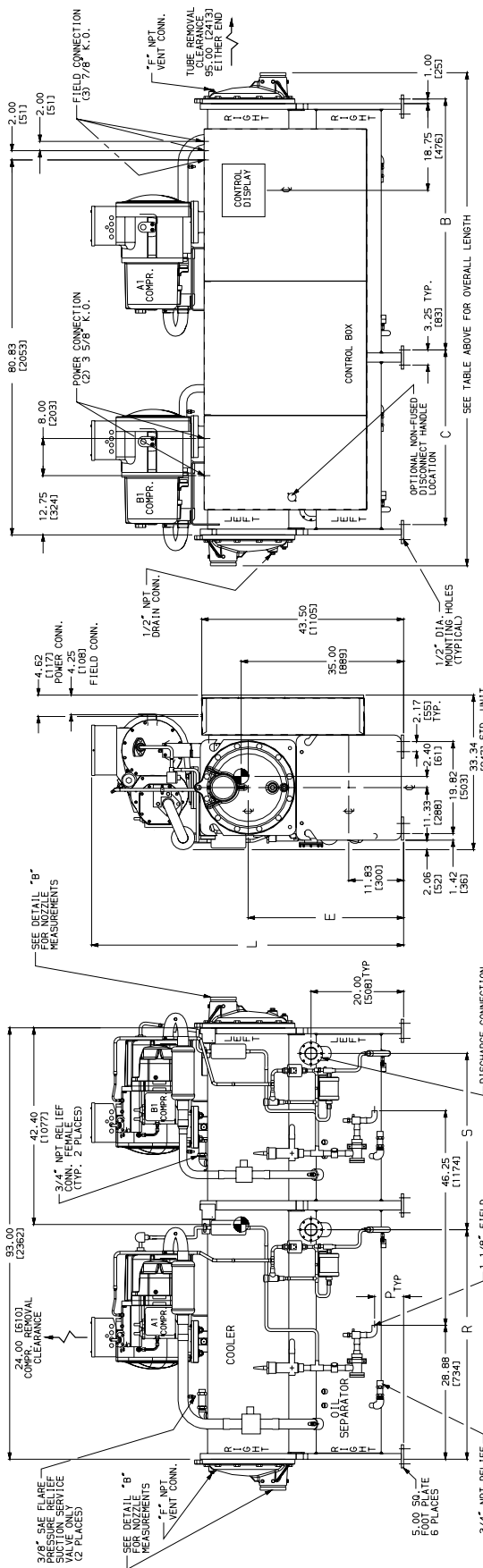
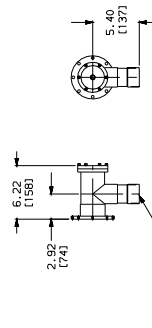

- NOTES:
- Operating weight includes weight of water and refrigerant.
 - Denotes center of gravity.
 - Dimensions are in inches (mm).
 - Recommended service clearance around machine is 36 in. (914.4 mm).
 - Victaulic nozzles are standard on all models. Flow switch factory installed in cooler outlet victaulic nozzle.

30HXAI16-146

UNIT	WGT DISTRIBUTION AT EACH MTG PLATE - lb (kg)					
	1	2	3	4	5	6
30HXAI116	530 (240)	895 (406)	540 (245)	855 (388)	1456 (660)	887 (402)
30HXAI126	5205 (2362)	905 (410)	541 (245)	864 (392)	1468 (666)	887 (402)
30HXAI136	5309 (2408)	548 (249)	926 (420)	555 (252)	874 (396)	1498 (679)
30HXAI146	5333 (2420)	551 (250)	930 (422)	555 (252)	883 (400)	1506 (683)

OVERALL LENGTH TABLE

COOLER	OVERALL LENGTH
STANDARD COOLER	134.38 (3413)
MINUS ONE PASS COOLER	144.00 (3658)
PLUS ONE PASS COOLER	135.89 (3472)

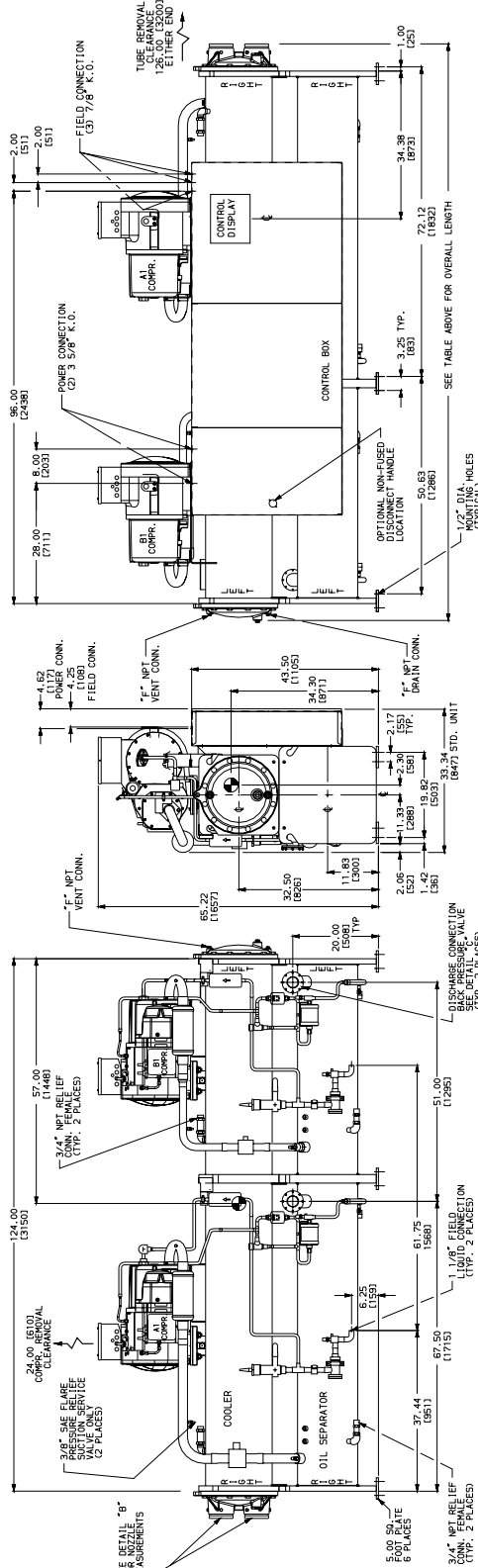
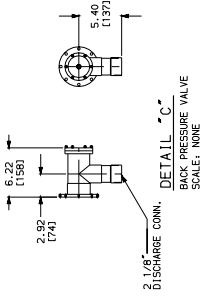

DOOR SWING CLEARANCE

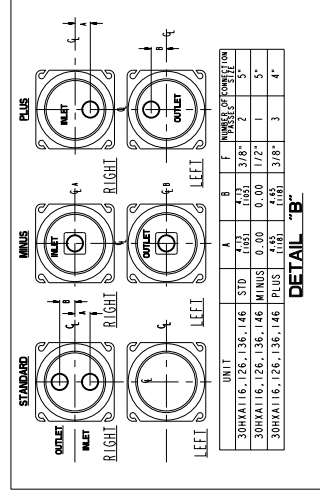
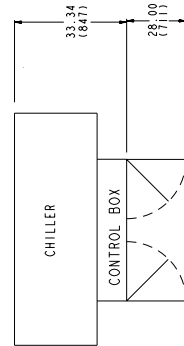

- NOTES:
- Operating weight includes weight of water and refrigerant.
 - Denotes center of gravity.
 - Dimensions are in inches (mm).
 - Recommended service clearance around machine is 36 in. (914.4 mm).
 - Victaulic nozzles are standard on all models. Flow switch factory installed in cooler outlet victaulic nozzle.

30HXA161-186

UNIT	OPERATING WEIGHT - lb (kg)	WGT DISTRIBUTION AT EACH MTG PLATE - lb (kg)						T	S	R	C	B
		1	2	3	4	5	6					
30HXA161	5752 (2610)	50.63 (1286)	67.50 (1715)	51.00 (1295)	48.75 (1238)	965 (254)	954 (438)	954 (433)	954 (433)	1650 (748)	1025 (465)	
30HXA171	5777 (2621)	61.37 (1559)	56.75 (1441)	61.75 (1532)	44.31 (1125)	627 (284)	627 (284)	534 (242)	534 (242)	1658 (752)	918 (416)	
30HXA186	5946 (2698)	61.37 (1559)	56.75 (1441)	61.75 (1532)	44.31 (1125)	648 (294)	648 (294)	1004 (455)	1110 (504)	1703 (772)	939 (426)	

OVERALL LENGTH TABLE	
COOLER	OVERALL LENGTH
STANDARD COOLER	131.48 (341.41)
MINUS ONE PASS COOLER	144.00 (365.81)
PLUS ONE PASS COOLER	137.30 (348.71)

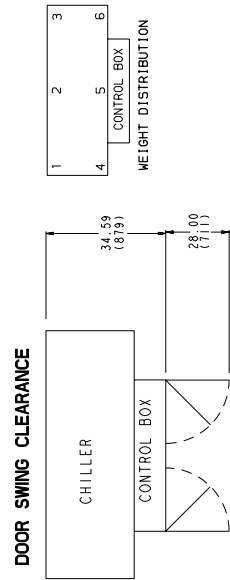
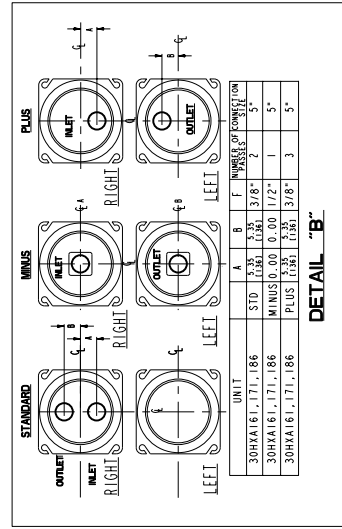
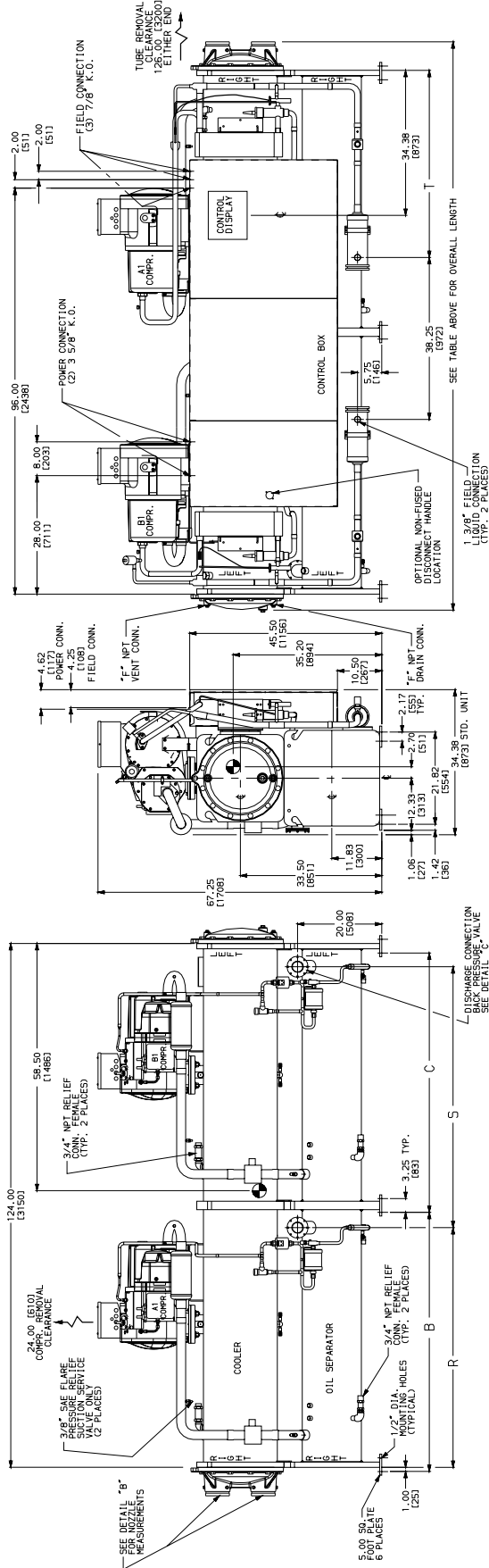
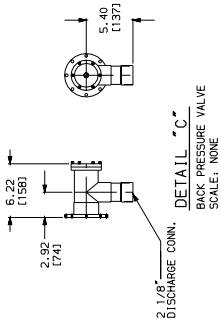

- NOTES:
- Operating weight includes weight of water and refrigerant.
 - Denotes center of gravity.
 - Dimensions are in inches (mm).
 - Recommended service clearance around machine is 36 in. (914.4 mm).
 - Victaulic nozzles are standard on all models. Flow switch factory installed in cooler outlet victaulic nozzle.



0HXA206-271

UNIT	OPERATING WEIGHT - lb (kg)	WGT DISTRIBUTION AT EACH MTG PLATE - lb (kg)					
		1	2	3	4	5	6
30HXA206	7485 (3395)	671 (304)	1702 (772)	879 (399)	850 (385)	2216 (1005)	1167 (529)
30HXA246	7621 (3457)	681 (309)	1748 (793)	911 (413)	797 (362)	2276 (1032)	1209 (548)
30HXA261	7621 (3457)	681 (309)	1748 (793)	911 (413)	797 (362)	2276 (1032)	1209 (548)
30HXA271	7621 (3457)	681 (309)	1748 (793)	911 (413)	797 (362)	2276 (1032)	1209 (548)

OVERALL LENGTH TABLE	
COOLER	OVERALL LENGTH
STANDARD COOLER	150.95 (13634)
MINUS ONE PASS COOLER	160.00 (14664)
PLUS ONE PASS COOLER	160.00 (14664)

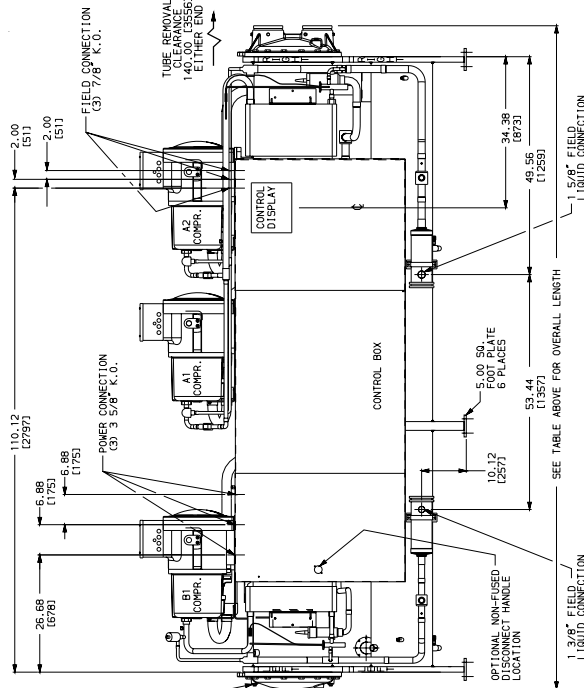
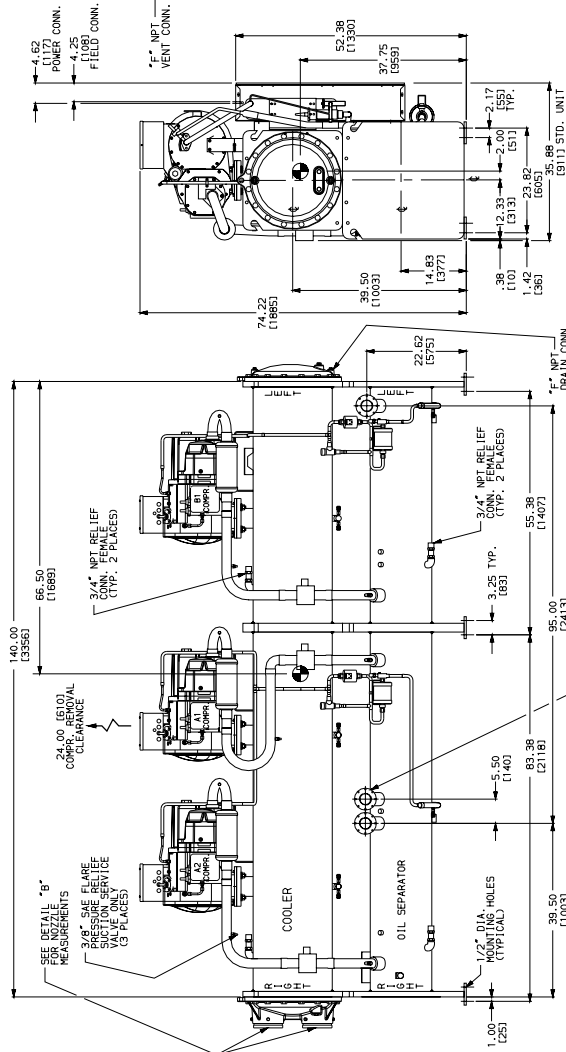
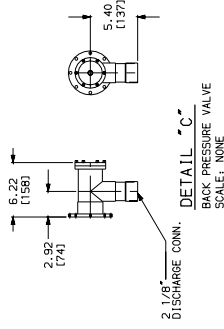

DOOR SWING CLEARANCE

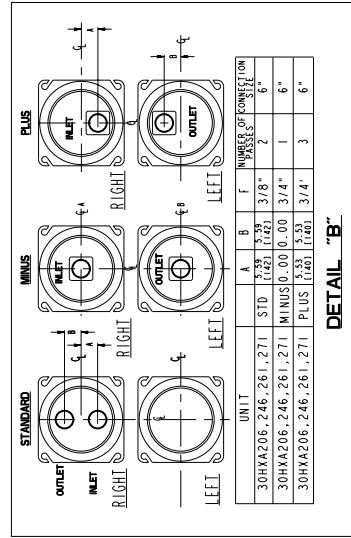
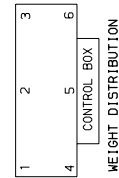
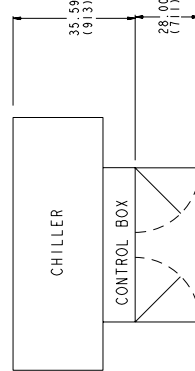

- NOTES:**
- Operating weight includes weight of water and refrigerant.
 - Denotes center of gravity.
 - Dimensions are in inches (mm).
 - Recommended service clearance around machine is 36 in. (914.4 mm).
 - Victaulic nozzles are standard on all models. Flow switch factory installed in cooler outlet victaulic nozzle.

ACCESSORY SOUND ENCLOSURE

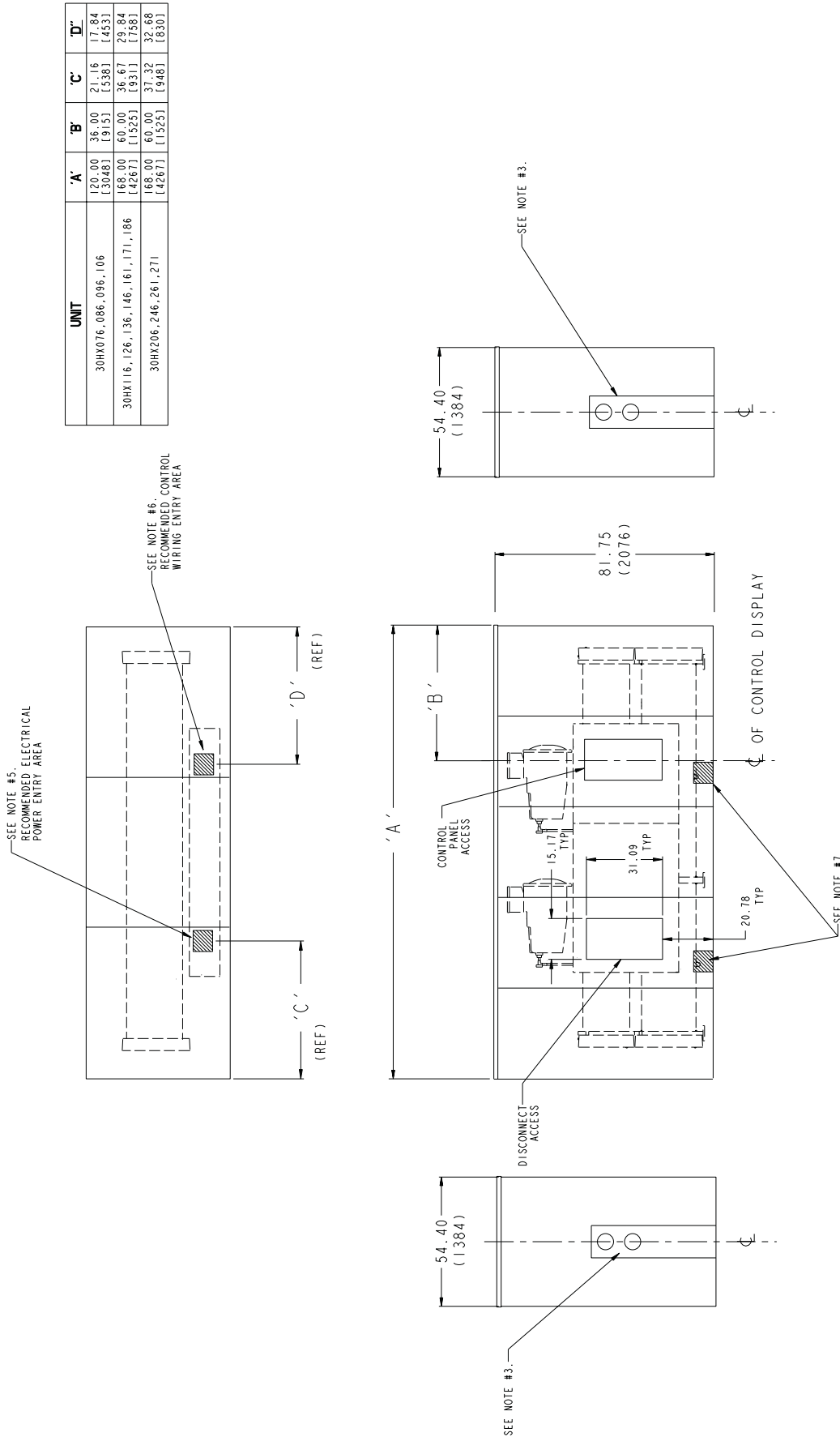

- NOTES:**
- Dimensions are in inches (millimeters).
 - Recommended service clearance around machine is 36 in. (914.4).
 - Unused portion of piping openings must be closed and insulated for acoustic purposes. Use filler panel in accessory package.
 - Field-fabricated holes must be closed and insulated for acoustic purposes.
 - Recommended electrical power supply area. Notch to suit and cover/insulate remaining open area for acoustic purposes.
 - Recommended control wiring entry area. Notch to suit and cover/insulate remaining open area for acoustic purposes.
 - Recommended cooler relief valve vent line and 30HXC condenser relief vent line entry area. The 30HXA discharge and liquid line entry areas are on opposite side. Notch enclosure to suit particular installation.
 - Model in drawing is typical and represents 30HX116-146 sizes in the 30HX-900--001 accessory sound enclosure.
 - Sound enclosure accessory should be aligned to the center lines of the control panel access and piping openings.

Dimensions (cont)



WEIGHT DISTRIBUTION AT MOUNTING PLATES

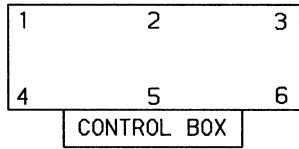

WEIGHT DISTRIBUTION AT EACH MOUNTING PLATE

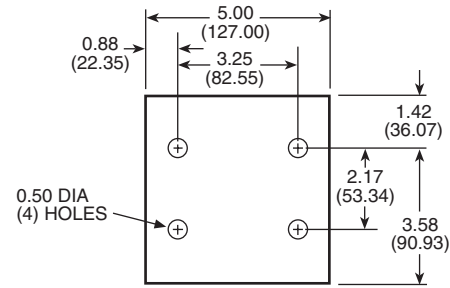

NOTE: Dimensions shown in inches (mm).
30HX FOOT

30HXC UNITS — lb (kg)

UNIT 30HXC	MOUNTING PLATE NO.					
	1	2	3	4	5	6
076	738 (335)	943 (428)	595 (270)	1110 (503)	1418 (643)	896 (406)
086	738 (335)	947 (430)	597 (271)	1112 (504)	1427 (647)	902 (409)
096	686 (311)	968 (439)	693 (314)	1027 (466)	1447 (656)	1034 (469)
106	730 (331)	1028 (466)	744 (337)	1073 (487)	1510 (685)	1092 (495)
116	728 (330)	1114 (505)	777 (352)	1053 (478)	1615 (733)	1127 (511)
126	738 (335)	1127 (511)	780 (354)	1061 (481)	1628 (738)	1131 (513)
136	758 (344)	1176 (533)	811 (368)	1083 (491)	1689 (766)	1171 (531)
146	763 (346)	1182 (536)	815 (370)	1085 (492)	1697 (770)	1172 (532)
161	817 (371)	1272 (577)	908 (412)	1219 (553)	1890 (857)	1346 (610)
171	936 (425)	1318 (598)	840 (381)	1379 (626)	1946 (883)	1241 (563)
186	962 (436)	1361 (617)	860 (390)	1410 (640)	1996 (905)	1265 (574)
206	948 (430)	2406 (1091)	1243 (564)	1201 (545)	3133 (1421)	1650 (748)
246	985 (447)	2515 (1141)	1306 (592)	1154 (523)	3276 (1486)	1733 (786)
261	985 (447)	2520 (1143)	1311 (595)	1154 (523)	3283 (1489)	1739 (789)
271	985 (447)	2529 (1147)	1318 (598)	1154 (523)	3294 (1494)	1749 (793)

30HXA UNITS — lb (kg)

UNIT 30HXA	MOUNTING PLATE NO.					
	1	2	3	4	5	6
076	555 (252)	793 (360)	418 (190)	926 (420)	1326 (601)	699 (317)
086	555 (252)	798 (362)	418 (190)	928 (421)	1340 (608)	705 (320)
096	509 (231)	808 (367)	493 (224)	848 (385)	1350 (612)	827 (375)
106	555 (252)	869 (394)	541 (245)	896 (406)	1410 (640)	880 (399)
116	530 (240)	895 (406)	540 (245)	855 (388)	1456 (660)	887 (402)
126	540 (245)	905 (410)	541 (245)	864 (392)	1468 (666)	887 (402)
136	548 (249)	926 (420)	555 (252)	873 (396)	1498 (679)	908 (412)
146	551 (250)	930 (422)	555 (252)	883 (400)	1506 (683)	908 (412)
161	560 (254)	965 (438)	598 (271)	954 (433)	1650 (748)	1025 (465)
171	627 (284)	968 (439)	534 (242)	1072 (486)	1658 (752)	918 (416)
186	648 (294)	1004 (455)	552 (250)	1110 (504)	1703 (772)	939 (426)
206	671 (304)	1702 (772)	879 (399)	850 (385)	2216 (1005)	1167 (529)
246	681 (309)	1748 (793)	911 (413)	797 (362)	2276 (1032)	1209 (548)
261	681 (309)	1748 (793)	911 (413)	797 (362)	2276 (1032)	1209 (548)
271	681 (309)	1748 (793)	911 (413)	797 (362)	2276 (1032)	1209 (548)

NOTE: See pages 11-18 for center of gravity details.

Application data



Unit location

Unit should be level (particularly in its major lengthwise dimension) to assure proper oil return.

The unit should be located indoors in an area of temperature greater than 50 F (10 C).

Good acoustic design practice should be followed, i.e., unit should not be located adjacent to sound-sensitive areas unless appropriate consideration has been made.

Cooler fluid temperature

1. *Maximum* leaving water (fluid) temperature (LWT) is 60 F (21 C). Unit can start and pull down with up to 95 F (35 C) entering water (fluid) temperature due to MOP (maximum operating pressure) feature of the expansion valve. For sustained operation, it is recommended that entering fluid temperature not exceed 70 F (21.1 C).
2. *Minimum* LWT is 40 F (4.4 C) for standard units. The brine option is required for operation with leaving fluid temperatures in the range of 39 to 12 F (4 to -9 C). For ratings below 40 F (4.4 C) LWT, contact your local Carrier representative.
3. *Minimum* entering water (fluid) temperature (EWT) is 45 F (7.2 C). *Maximum* EWT is 70 F (21.1 C).

Leaving-fluid temperature reset

The accessory reset sensor can be applied to the chiller to provide reset of in LWT constant fluid flow systems. Reset reduces compressor power usage at part load when design LWT is not necessary. Humidity control should be considered, since higher coil temperatures resulting from reset will reduce latent heat capacity. Three reset applications are offered:

From return-fluid temperature — Increases LWT set point as return (or entering) fluid temperature decreases (indicating load decrease). Reset from return fluid may be used in any application where return fluid provides accurate load indication. Limitation of return-fluid reset is that the LWT may only be reset to value of design return-fluid temperature. No additional hardware is required.

From outdoor-air temperature — Increases LWT as outdoor ambient temperature decreases (indicating load decrease). This reset should be applied only where outdoor ambient temperature is an accurate indication of load. A field-supplied thermistor is required.

From occupied space temperature — Increases LWT as space temperature decreases (indicating load decrease). This reset should be applied only where space temperature is an accurate indication of load. A field-supplied thermistor is required.

Temperature can also be reset using a 4 to 20 mA signal from the control system. This type of reset requires the Energy Management Module Accessory.

Condenser fluid temperature

1. *Maximum* leaving condenser fluid temperature is 105 F (40.5 C) on all 30HXC units.

2. *Standard* 30HXC units will start at entering condenser fluid temperatures above 55 F (12.8 C). In general, however, continuous machine operation with entering condenser fluid temperatures below 70 F (21.1 C) is not recommended. When the entering condenser fluid temperature is expected to drop below 70 F (21.1 C), it is recommended that some form of condenser flow control be used to optimize performance. Tower pump, bypass valves, or flow regulating valves may be controlled by a 4 to 20 mA output from the 30HXC control (60-second open to close time recommended for actuator).

Cooler and water-cooled condenser temperature rise

Ratings and performance data in this publication are for a cooling temperature rise of 10° F (5.6° C). Units may be operated at a different temperature rise, provided flow limits are not exceeded and corrections to capacity, etc., are made. For minimum flow rates, see the Minimum Flow Rates table. High flow rate is limited by pressure drop that can be tolerated.

Minimum cooler flow — Flow (maximum cooler temperature rise) is shown in the Minimum Flow Rates table. Minimum flow rate must be maintained to prevent fouling. When gpm (L/s) required is lower (or rise is higher), follow recommendations below:

1. Multiple smaller chillers can be applied in series, each providing a portion of the design temperature rise.
2. Chilled fluid can be recirculated to raise flow rate. However, mixed temperature entering cooler must be maintained at a minimum of at least 5° F (2.8° C) above the leaving chilled fluid temperature.
3. Special plus one-pass cooler can be used. Contact your Carrier representative for further information.

Maximum cooler flow (> 5 gpm/ton or < 5° F rise [> 0.09 L/s · kW or < 2.7° C rise]) — Maximum flow results in practical maximum pressure drop through cooler. Special minus-one-pass cooler can be used to reduce pressure drop. Contact your Carrier representative.

Return fluid can bypass the cooler to keep pressure drop through cooler within acceptable limits. This permits a higher ΔT with lower fluid flow through cooler and mixing after the cooler. Contact your Carrier representative if pressure drop appears excessive.

Variable cooler flow rates — These variable rates may be applied to standard 30HX series chillers. However, the unit will attempt to maintain a constant leaving chilled-fluid temperature. In such cases, minimum fluid loop volume must be in excess of 3 gal per ton (3.2 L per kW) and flow rate must change in steps of less than 10% per minute. Apply 6 gal per ton (6.5 L per kW) fluid loop volume minimum if flow rate changes more rapidly.

Minimum water-cooled condenser flow — This value (maximum rise) is shown in Minimum Flow Rates table. Ensure leaving-fluid temperature does not exceed 105 F (40.5 C).

Application data (cont)



MINIMUM FLOW RATES

DEVICE	UNIT SIZE 30HX	COOLER		MIN. FLOW RATE*		COOLER TEMP DIFFERENCE	
		No. of Passes	Type	GPM	L/s	F	C
COOLER	076	2	Minus 1	136.0	8.6	13	7.4
		3	Standard	90.0	5.7	20	11.1
		4	Plus 1	68.0	4.3	27	14.8
	086	2	Minus 1	149.0	9.4	13	7.4
		3	Standard	100.0	6.3	20	11.1
		4	Plus 1	75.0	4.7	27	14.8
	096	2	Minus 1	169.0	10.7	13	7.4
		3	Standard	113.0	7.1	20	11.1
		4	Plus 1	85.0	5.3	27	14.8
	106	2	Minus 1	188.0	11.8	13	7.4
		3	Standard	125.0	7.9	20	11.1
		4	Plus 1	94.0	5.9	27	14.8
	116	1	Minus 1	272.0	17.2	10	5.6
		2	Standard	136.0	8.6	20	11.1
		3	Plus 1	91.0	5.7	30	16.7
	126	1	Minus 1	295.0	18.6	10	5.6
		2	Standard	147.0	9.3	20	11.1
		3	Plus 1	98.0	6.2	30	16.7
	136	1	Minus 1	327.0	20.7	10	5.6
		2	Standard	164.0	10.3	20	11.1
		3	Plus 1	109.0	6.9	30	16.7
	146	1	Minus 1	350.0	22.1	10	5.6
		2	Standard	175.0	11.0	20	11.1
		3	Plus 1	117.0	7.4	30	16.7
	161	1	Minus 1	376.0	23.7	10	5.6
		2	Standard	188.0	11.9	20	11.1
		3	Plus 1	125.0	7.9	30	16.7
	171	1	Minus 1	399.0	25.2	10	5.6
		2	Standard	199.0	12.6	20	11.1
		3	Plus 1	133.0	8.4	30	16.7
186	1	Minus 1	426.0	26.9	10	5.6	
	2	Standard	213.0	13.4	20	11.1	
	3	Plus 1	142.0	9.0	30	16.7	
206	1	Minus 1	508.0	32.1	10	5.6	
	2	Standard	254.0	16.0	20	11.1	
	3	Plus 1	169.0	10.7	30	16.7	
246	1	Minus 1	597.0	37.7	10	5.6	
	2	Standard	309.0	18.8	20	11.1	
	3	Plus 1	199.0	12.6	30	16.7	
261	1	Minus 1	618.0	39.0	10	5.6	
	2	Standard	309.0	19.5	20	11.1	
	3	Plus 1	206.0	13.0	30	16.7	
271	1	Minus 1	642.0	40.5	10	5.6	
	2	Standard	321.0	20.3	20	11.1	
	3	Plus 1	214.0	13.5	30	16.7	
CONDENSER	076,086	2	—	105	6.6	—	—
	096,106	2	—	135	8.5	—	—
	116,126	2	—	170	10.7	—	—
	136,146	2	—	195	12.3	—	—
	161	2	—	235	14.8	—	—
	171,186	2	—	255	16.1	—	—
	206	2	—	273	17.2	—	—
	246	2	—	333	21.0	—	—
	261	2	—	333	21.0	—	—
271	2	—	333	21.0	—	—	

*Based on 20 F (11.1 C) temperature difference at ARI conditions.

NOTES:

- The 30HX units will start with loop temperatures up to 95 F (35 C).
- Minimum flow rate shown is based on ARI Ratings and is for reference only. **20 F (11.1 C) is the maximum cooler temperature differential that will determine actual minimum flow rate.**
- To obtain proper temperature control, loop fluid volume must be at least 3 gal/ton (3.23 L/kW) of chiller nominal capacity for air conditioning and at least 6 gal/ton (6.5 L/kW) for process applications.

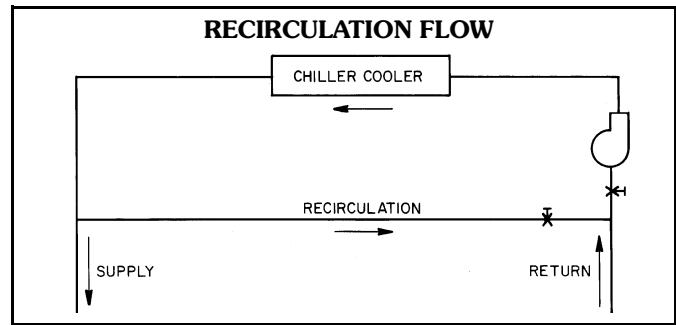

Oversizing chillers

Oversizing chillers by more than 15% at design conditions must be avoided as the system operating efficiency will be adversely affected (resulting in greater and/or excessive electrical demand and cycling of compressors). When future expansion of equipment is anticipated, install a single chiller to meet present load requirements, and install a second chiller to meet the additional load demand.

It is also recommended that the installation of 2 smaller chillers be considered where operation at minimum load is critical. The operation of 2 small chillers at higher loading is preferred to operating a single chiller at or near its minimum recommended value.

The minimum load control accessory should not be used as a means to allow oversizing chillers. Minimum load control should be given consideration where substantial operating time is anticipated below the minimum unloading step.

Parallel chillers

Where chiller capacities greater than can be supplied by a single 30HX chiller are required, or where stand-by capability is desired, chillers may be installed in parallel. Units may be of the same or different sizes. However, cooler and condenser flow rates must be balanced to ensure proper flow to each chiller. The standard 30HX *ComfortLink™* control can be configured to provide lead/lag control for two chillers. The accessory Chillervisor™ System Manager III control may be used for proper leaving chilled fluid temperature control and to ensure proper staging sequence of up to 8 chillers. Refer to the accessory Chillervisor System Manager III installation instructions for further details.

Series chillers

Chillers in series may be used for capacities greater than those supplied by a single 30HX chiller. Using the Minus-One-Pass Cooler Head option, fluid pressure drop across the cooler can be held to reasonable levels. The leaving fluid temperature sensors need not be relocated. However, the cooler minimum entering fluid temperature limitations should be considered for the chillers located downstream of other chillers. The standard 30HX control can control two 30HX chillers in series. Condensers should be piped in parallel to maximize capacity and efficiency. This should also minimize condenser pressure drop and saturated condensing temperatures. However, if condensers are piped in series, ensure that the leaving fluid temperature does not exceed 105 F (40.5 C).

Energy management

Demand limiting and load shedding are popular techniques used to reduce peak electric demands typically experienced during hot summer days when air conditioning loads are highest. When utility electricity demands exceed a certain level, electrical loads are turned off to keep the peak demands below a prescribed maximum limit. Compressor unloading reduces electrical demand while allowing the chiller to operate under part-load capacity and to maintain partial chilled fluid cooling.

Electrical demand can be limited through demand limit input to chiller control which unloads the chiller to a predetermined percentage of the load. One stage of unloading can be initiated by a remote signal to significantly reduce the chiller power consumption. This power reduction applies to the full load power at nominal conditions. The demand limit control should not be cycled less than 10 minutes on and 5 minutes off.

Duty cycling

Duty cycling will cycle an electrical load at regular intervals, regardless of electrical demand. This reduces the electrical demand by “fooling” demand measuring devices. Duty cycling of the entire compressor is **NOT** recommended since motor windings and bearings will be damaged by constant cycling.

Wye-delta start

Wye-delta start is standard on 30HX 208/230-v, 60-Hz units and 230-v, 50-Hz units and optional on all other 30HX units. This feature is not always required on 30HX units due to the use of multiple compressors that allow small electrical load increments, but is available if required. Maximum instantaneous current flow (see ICF in Electrical Data tables on pages 59-62) should be used in determining need.

Vibration isolation

External vibration isolators are available as field-installed accessories.

Strainers

A strainer with a minimum screen size of 20 mesh must be installed in both the cooler and condenser fluid lines, within 10 ft (3 m) of the inlets to both the cooler and condenser. For 30HXA units, this requirement applies only to the cooler.

Chilled fluid loop volume

The chilled fluid loop volume in circulation must equal or exceed 3 gal per nominal ton of cooling (3.2 L per kW) for temperature stability and accuracy in normal air conditioning applications. For example, a 30HXC096 with a nominal capacity of 94.0 tons would require 282 gal (1067.4 L) in circulation in the system loop.

For process jobs where accuracy is vital, or for operation at ambient temperatures below 32 F (0° C) with low unit loading conditions, there should be from 6 to 10 gal per ton (6.5 to 10.8 L per kW). To achieve this volume, it is often necessary to install a tank in the loop. Tank should be baffled to ensure there is no stratification, and that water (or brine) entering the tank is adequately mixed with liquid in the tank. See Tank Installation drawing.

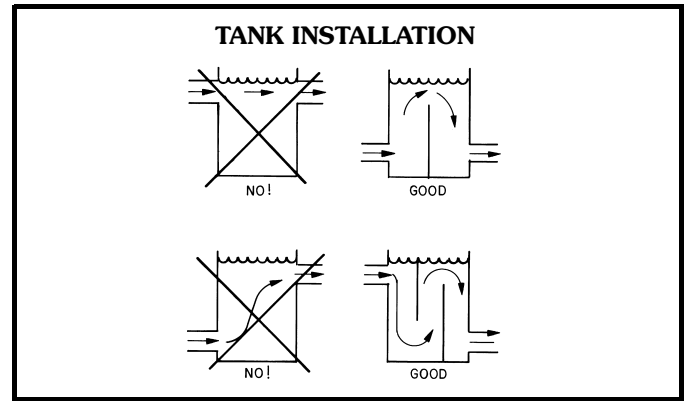

Fouling factor

The factor used to calculate tabulated ratings for the cooler is 0.00010 ft² · hr · F/Btu (0.000018 m² · K/W), and for the condenser is 0.00025 ft² · hr · F/Btu (0.00044 m² · K/W). As fouling factor is increased, unit capacity decreases and compressor power increases. To determine selections at other fouling factors, use the chiller program in the electronic catalog.

Cooler and water-cooled condenser freeze protection

If chiller refrigerant or fluid lines are in an area where ambient conditions fall below 32 F (0° C), it is recommended that an antifreeze solution be added to protect the unit and fluid piping to a temperature 12° F (6.7° C) below the lowest anticipated temperature. For corrections to performance, refer to the chiller program in the electronic catalog.

Use only antifreeze solutions approved for heat exchanger duty. Use of automotive antifreezes is not recommended because of the fouling that can occur once their relatively short-lived inhibitors break down.

If the system will not be used during freezing weather conditions and the chiller and fluid piping are not protected with an antifreeze solution, it is recommended that the chiller and outdoor piping be drained.

Refer to Cooler Fluid Temperature section, page 21, for leaving fluid temperature for brine units. When leaving chilled fluid temperatures will be lower than 40 F (4.4 C), an appropriate antifreeze solution must be used in the cooler. In addition, the following special installation instructions will apply:

1. In addition to the factory-mounted chilled water flow switch, a field-supplied condenser water flow switch must be installed.
2. The chiller must control both the chilled water pump and the condenser pump. The cooler pump must operate for a minimum of 10 minutes after the chiller has shut down and the condenser pump must operate for a minimum of 30 minutes after the chiller has shut down. In the event of a loss of condenser water flow, the flow of chilled fluid to the evaporator must be stopped or the isolation valve must be closed. This is necessary to reduce the possibility of condenser freeze-up.

Application data (cont)



3. Condenser head pressure control valves must not reduce condenser flow below 0.75 gallons per ton (0.4 L/s per kW) or the lowest detectable flow level of the condenser water flow switch. For further information, refer to the 30HX Installation Instructions or contact your Carrier representative.

30HXA remote condenser requirements

1. Do not manifold independent refrigerant circuits into a single condenser circuit.
2. Ensure each refrigerant circuit has its own head pressure control.
3. Condensing pressure control must be provided on condensers used with 30HXA to maintain a minimum 75 F (24 C) saturated discharge temperature at light loads.
4. Condenser must provide 15° F (8.3° C) subcooling, a maximum of 40° F (22.2° C) difference between saturated condensing temperature and outdoor ambient temperature (to prevent overload at high ambient temperatures), and a minimum of 20° F (11.1° C) difference (to assure subcooling).
5. Minimum saturated discharge temperature (SDT) is 90 F (32.2 C). Maximum SDT is 135 F (57.2 C) at full load.
6. Condenser should not be located more than 15 ft (4.6 m) below chiller to maintain subcooling.
7. Design discharge and liquid piping according to Carrier System Design Manual. Piping must be sized for HFC-134a. Refer to the ASHRAE Refrigeration Handbook for R-134a sizing tables. Also see 30HX Installation instructions and the Typical 30HXA Refrigerant Piping to Remote Condenser diagrams on page 29.
8. Maximum interconnecting refrigerant line length is 200 ft (61 m) actual.
9. Liquid line solenoid valves are required.
10. If accessory sound enclosure is installed, run lines along the floor so the sound enclosure can be notched to clear lines.

Refrigerant pipe sizing for 30HXA with Carrier 09D condenser combinations — For refrigerant pipe sizing of the 30HXA follow these directions:

Discharge line:

1. For applications at conditions of 40 F (4.4 C) or higher, use the Refrigerant Line Sizes for 30HXA Chiller/09DK Condenser Combinations tables on pages 25 and 26.
For applications using brine, other condensers, or LWT below 40 F (4.4 C), size lines using the ASHRAE Refrigeration Handbook, or other suitable design guide.
2. Install horizontal lines level or pitched slightly toward the base of discharge riser and the condenser (in the direction of flow).
3. If chiller is below the condenser, loop the discharge line to at least one inch (25.4 mm) above the top of condenser.

4. A double discharge riser (as shown in Refrigerant Line Sizes, Double Discharge Riser Pipe Sizes table on page 26) is required if any of the following conditions exist:
 - a. Unit is equipped with minimum load control.
 - b. Chiller is located below condenser.
 - c. Discharge line size is in shaded area in Refrigerant Line Sizes, Recommended Refrigerant Pipe Sizes table on page 25.
5. Minimize line length and restrictions to minimize pressure drop and refrigerant charge.
6. If accessory sound enclosure is applied, run lines along the floor so sound enclosure may be notched to clear lines.
7. Lines should not be buried underground.

Liquid line:

1. For applications at conditions of 40 F (4.4 C) or higher LWT, use the Refrigerant Line Sizes for 30HXA Chiller/09DK Condenser Combinations tables on pages 25 and 26.
For applications using brine, other condensers, or LWT below 40 F (4.4 C), size lines using the ASHRAE Refrigeration Handbook, or other suitable design guide.
2. If chiller is above condenser, maximum vertical separation is 15 ft (4.6 m).
3. Minimize line length and restrictions to minimize pressure drop and refrigerant charge.
4. Field-supplied liquid line solenoid valves are required. The solenoid valves must be located close to the chiller.
5. If sound enclosure is applied, run lines along floor so sound enclosure may be notched to clear lines.
6. In-line receivers are NOT recommended due to their negative effect on system subcooling. Where the use of a receiver is desired for service purposes, the receiver should be piped in parallel with the main liquid line and equipped with shut-off valves to isolate it during unit operation. See sketch below.
7. Filter driers (field supplied) are required.

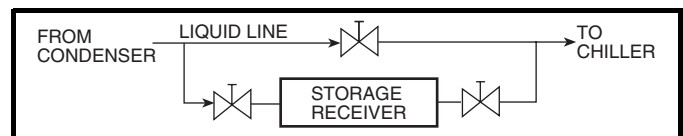

Relief valve vent lines

1. Vent per local code requirements.
2. Each chiller has a minimum of 4 refrigerant relief valves: 2 on the cooler, 2 on the condenser (30HXC) or oil separator (30HXA). Units with factory-installed suction service valves also have one relief valve on each compressor discharge line. See Dimensions section on pages 11-18 for specific locations.
3. If sound enclosure is applied, run lines along floor so sound enclosure may be notched to clear lines.



REFRIGERANT LINE SIZES FOR 30HXA CHILLER/09DK CONDENSER COMBINATIONS
RECOMMENDED REFRIGERANT PIPE SIZES (in. OD)

30HXA UNIT SIZE	CKT	TOTAL LENGTH OF INTERCONNECTING PIPING — FT (M)					
		0-50 (0-15)		50-100 (15-30)		100-200 (30-60)	
		Liquid Line*	Discharge Line†	Liquid Line*	Discharge Line†	Liquid Line*	Discharge Line†
076	A	1 ¹ / ₈	2 ¹ / ₈	1 ¹ / ₈	2 ¹ / ₈	1 ³ / ₈	2 ¹ / ₈
	B	1 ¹ / ₈	2 ¹ / ₈	1 ¹ / ₈	2 ¹ / ₈	1 ³ / ₈	2 ¹ / ₈
086	A	1 ¹ / ₈	2 ¹ / ₈	1 ³ / ₈	2 ¹ / ₈	1 ³ / ₈	2 ¹ / ₈
	B	1 ¹ / ₈	2 ¹ / ₈	1 ¹ / ₈	2 ¹ / ₈	1 ³ / ₈	2 ¹ / ₈
096	A	1 ¹ / ₈	2 ¹ / ₈	1 ³ / ₈	2 ¹ / ₈	1 ⁵ / ₈	2 ⁵ / ₈
	B	1 ¹ / ₈	2 ¹ / ₈	1 ¹ / ₈	2 ¹ / ₈	1 ³ / ₈	2 ¹ / ₈
106	A	1 ³ / ₈	2 ¹ / ₈	1 ³ / ₈	2 ⁵ / ₈	1 ⁵ / ₈	2 ⁵ / ₈
	B	1 ³ / ₈	2 ¹ / ₈	1 ¹ / ₈	2 ¹ / ₈	1 ³ / ₈	2 ¹ / ₈
116	A	1 ³ / ₈	2 ¹ / ₈	1 ³ / ₈	2 ⁵ / ₈	1 ⁵ / ₈	2 ⁵ / ₈
	B	1 ³ / ₈	2 ¹ / ₈	1 ³ / ₈	2 ¹ / ₈	1 ³ / ₈	2 ¹ / ₈
126	A	1 ³ / ₈	2 ¹ / ₈	1 ³ / ₈	2 ⁵ / ₈	1 ⁵ / ₈	2 ⁵ / ₈
	B	1 ³ / ₈	2 ¹ / ₈	1 ³ / ₈	2 ¹ / ₈	1 ⁵ / ₈	2 ⁵ / ₈
136	A	1 ³ / ₈	2 ⁵ / ₈	1 ⁵ / ₈	2 ⁵ / ₈	1 ⁵ / ₈	3 ¹ / ₈
	B	1 ³ / ₈	2 ¹ / ₈	1 ³ / ₈	2 ¹ / ₈	1 ⁵ / ₈	2 ⁵ / ₈
146	A	1 ³ / ₈	2 ⁵ / ₈	1 ⁵ / ₈	2 ⁵ / ₈	1 ⁵ / ₈	3 ¹ / ₈
	B	1 ³ / ₈	2 ¹ / ₈	1 ³ / ₈	2 ⁵ / ₈	1 ⁵ / ₈	2 ⁵ / ₈
161	A	1 ³ / ₈	2 ⁵ / ₈	1 ⁵ / ₈	2 ⁵ / ₈	2 ¹ / ₈	3 ¹ / ₈
	B	1 ³ / ₈	2 ¹ / ₈	1 ³ / ₈	2 ⁵ / ₈	1 ⁵ / ₈	2 ⁵ / ₈
171	A	1 ³ / ₈	2 ⁵ / ₈	1 ⁵ / ₈	2 ⁵ / ₈	1 ⁵ / ₈	3 ¹ / ₈
	B	1 ³ / ₈	2 ⁵ / ₈	1 ⁵ / ₈	2 ⁵ / ₈	2 ¹ / ₈	3 ¹ / ₈
186	A	1 ³ / ₈	2 ⁵ / ₈	1 ⁵ / ₈	2 ⁵ / ₈	2 ¹ / ₈	3 ¹ / ₈
	B	1 ³ / ₈	2 ⁵ / ₈	1 ⁵ / ₈	2 ⁵ / ₈	2 ¹ / ₈	3 ¹ / ₈
206	A	1 ⁵ / ₈	2 ⁵ / ₈	1 ⁵ / ₈	3 ¹ / ₈	2 ⁵ / ₈	3 ¹ / ₈
	B	1 ³ / ₈	2 ⁵ / ₈	1 ⁵ / ₈	2 ⁵ / ₈	2 ¹ / ₈	3 ¹ / ₈
246	A	2 ¹ / ₈	3 ¹ / ₈	2 ⁵ / ₈	3 ¹ / ₈	2 ⁵ / ₈	3 ¹ / ₈
	B	1 ³ / ₈	2 ⁵ / ₈	1 ⁵ / ₈	2 ⁵ / ₈	2 ⁵ / ₈	3 ¹ / ₈
261	A	2 ¹ / ₈	3 ¹ / ₈	2 ⁵ / ₈	3 ¹ / ₈	2 ⁵ / ₈	3 ¹ / ₈
	B	1 ³ / ₈	2 ⁵ / ₈	1 ⁵ / ₈	2 ⁵ / ₈	2 ¹ / ₈	3 ¹ / ₈
271	A	2 ¹ / ₈	3 ¹ / ₈	2 ⁵ / ₈	3 ¹ / ₈	2 ⁵ / ₈	3 ¹ / ₈
	B	1 ³ / ₈	2 ⁵ / ₈	1 ⁵ / ₈	2 ⁵ / ₈	2 ¹ / ₈	3 ¹ / ₈

LEGEND

OD — Outside Diameter

*Field-supplied liquid line solenoid valve is required.

†Double discharge riser is required on **ALL** units which have minimum load control installed.

█ Values indicate double discharge riser required on STANDARD unit. See Double Discharge Riser Pipe Sizes table on page 26.

NOTES:

1. Refrigerant and Double Discharge Riser Pipe Sizes tables are based on equal chiller and 09DK condenser sizes — i.e., 30HXA096 with 09DK094.
2. For other system combinations, size lines per ASHRAE (American Society of Heating, Refrigerating, and Air Conditioning Engineers) or other R-134a line sizing guide.
3. Refrigerant and Double Discharge Riser Pipe Sizes tables are based on cooler leaving water temperatures of 40 F (4.4 C) or above.
4. Pipe diameter calculation is based on actual line length plus a 50% allowance for fittings.

Application data (cont)



REFRIGERANT LINE SIZES FOR 30HXA CHILLER/09DK CONDENSER COMBINATIONS (cont) DOUBLE DISCHARGE RISER PIPE SIZES (in. OD)

30HXA UNIT SIZE	CKT	RISER "A"		RISER "B"	
		Total Length of Interconnecting Piping — FT (M)*			
		0-200 (0-60)	0-50 (0-15)	50-100 (15-30)	100-200 (30-60)
076	A	1 ¹ / ₈	1 ⁵ / ₈	1 ⁵ / ₈	1 ⁵ / ₈
	B	1 ¹ / ₈	1 ⁵ / ₈	1 ⁵ / ₈	1 ⁵ / ₈
086	A	1 ¹ / ₈	1 ⁵ / ₈	1 ⁵ / ₈	1 ⁵ / ₈
	B	1 ¹ / ₈	1 ⁵ / ₈	1 ⁵ / ₈	1 ⁵ / ₈
096	A	1 ¹ / ₈	1 ⁵ / ₈	1 ⁵ / ₈	2 ¹ / ₈
	B	1 ¹ / ₈	1 ⁵ / ₈	1 ⁵ / ₈	1 ⁵ / ₈
106	A	1 ⁵ / ₈	1 ⁵ / ₈	2 ¹ / ₈	2 ¹ / ₈
	B	1 ³ / ₈	1 ³ / ₈	1 ³ / ₈	1 ³ / ₈
116	A	1 ⁵ / ₈	1 ⁵ / ₈	2 ¹ / ₈	2 ¹ / ₈
	B	1 ³ / ₈	1 ⁵ / ₈	1 ⁵ / ₈	1 ⁵ / ₈
126	A	1 ⁵ / ₈	2 ¹ / ₈	2 ¹ / ₈	2 ¹ / ₈
	B	1 ³ / ₈	1 ⁵ / ₈	1 ⁵ / ₈	2 ¹ / ₈
136	A	1 ⁵ / ₈	2 ¹ / ₈	2 ¹ / ₈	2 ⁵ / ₈
	B	1 ³ / ₈	1 ⁵ / ₈	1 ⁵ / ₈	2 ¹ / ₈
146	A	1 ⁵ / ₈	2 ¹ / ₈	2 ¹ / ₈	2 ⁵ / ₈
	B	1 ⁵ / ₈	1 ⁵ / ₈	2 ¹ / ₈	2 ¹ / ₈
161	A	1 ⁵ / ₈	2 ¹ / ₈	2 ¹ / ₈	2 ⁵ / ₈
	B	1 ⁵ / ₈	1 ⁵ / ₈	2 ¹ / ₈	2 ¹ / ₈
171	A	1 ⁵ / ₈	2 ¹ / ₈	2 ¹ / ₈	2 ⁵ / ₈
	B	1 ⁵ / ₈	2 ¹ / ₈	2 ¹ / ₈	2 ⁵ / ₈
186	A	1 ⁵ / ₈	2 ¹ / ₈	2 ¹ / ₈	2 ⁵ / ₈
	B	1 ⁵ / ₈	2 ¹ / ₈	2 ¹ / ₈	2 ⁵ / ₈
206	A	1 ⁵ / ₈	2 ¹ / ₈	2 ¹ / ₈	2 ⁵ / ₈
	B	1 ⁵ / ₈	2 ¹ / ₈	2 ¹ / ₈	2 ⁵ / ₈
246	A	1 ⁵ / ₈	2 ¹ / ₈	2 ¹ / ₈	2 ⁵ / ₈
	B	1 ⁵ / ₈	2 ¹ / ₈	2 ¹ / ₈	2 ⁵ / ₈
261	A	1 ⁵ / ₈	2 ¹ / ₈	2 ¹ / ₈	3 ¹ / ₈
	B	1 ⁵ / ₈	2 ¹ / ₈	2 ¹ / ₈	2 ⁵ / ₈
271	A	1 ⁵ / ₈	2 ¹ / ₈	3 ¹ / ₈	3 ¹ / ₈
	B	1 ⁵ / ₈	2 ¹ / ₈	2 ¹ / ₈	2 ⁵ / ₈

LEGEND

- A** — Riser Without Trap
- B** — Riser With Trap
- OD** — Outside Diameter

*Total Length of Interconnecting Piping refers to actual length, not total equivalent length.

NOTE: Horizontal line sections should be sized according to the Total Length of Interconnecting Piping columns on the Recommended Refrigerant Pipe Sizes table on page 25.

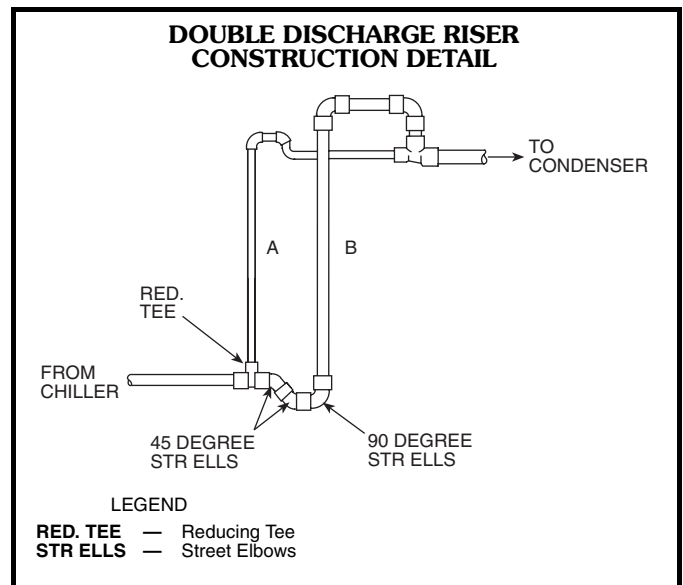



For chillers using brine or those matched with other condensers, the lines must be sized manually using design guides such as ASHRAE, or curves in the 30HXA installation instructions. In many 30HXA sizes, the individual refrigerant circuits have unequal capacities. The Circuit Cooling Capacity table below lists the percentage capacity of each circuit for line sizing purposes. The Circuit Unloading Capacity table below indicates the minimum unloading capacities per circuit as well as a sample calculation of the minimum circuit tonnage for riser design. The example below lists circuit capacity calculations based on the Circuit Cooling and Circuit Unloading Capacity tables.

CIRCUIT COOLING CAPACITY

30HXA UNIT SIZE	PERCENT OF TOTAL UNIT CAPACITY	
	Circuit A %	Circuit B %
076	50	50
086	55	45
096	59	41
106	64	36
116	60	40
126	55	45
136	59	41
146	55	45
161	59	41
171	47	53
186	50	50
206	54	46
246	61	39
261	63	37
271	64	36

CIRCUIT UNLOADING CAPACITY

30HXA UNIT	MINIMUM CIRCUIT CAPACITY — PERCENT OF FULL LOAD	
	Standard Unit	With Minimum Load Control
All Sizes, All Circuits	40%	20%

Example Calculation of Circuit Capacities:

Select (Standard) 30HXA086 Chiller

From Electronic catalog (E-cat) selection or balance diagram:

Total Unit Capacity = 74 tons (from unit selection at design conditions)

Using the Circuit Cooling Capacity table:

Ckt "A" design capacity = $74 \times 0.55 = 40.7$ tons

Using the Circuit Unloading Capacity table:

Ckt "A" minimum capacity = $40.7 \times 0.40 = 16.3$ tons

Ckt "B" design capacity = $74 \times 0.45 = 33.3$ tons

Ckt "B" minimum capacity = $33.3 \times 0.40 = 13.3$ tons

System refrigerant charge — The 30HXA units are shipped from the factory with a small holding charge of R-134a refrigerant. The approximate refrigerant charge required for starting the 30HXA system is listed in the table on next page. This initial charge will allow starting of the unit. Additional refrigerant may be required to accommodate liquid line storage. See the liquid line refrigerant storage capacity table below for liquid line storage information.

LIQUID LINE REFRIGERANT STORAGE CAPACITY

PIPING SIZE (in.)	REFRIGERANT (lb) PER FT OF TUBING LENGTH	REFRIGERANT (kg) PER M OF TUBING LENGTH
1 ¹ / ₈	0.41	0.61
1 ³ / ₈	0.63	0.94
1 ⁵ / ₈	0.89	1.33
2 ¹ / ₈	1.52	2.26
2 ⁵ / ₈	2.32	3.45

Application data (cont)



SYSTEM REFRIGERANT CHARGE FOR START-UP

30HXA	REFRIGERANT CIRCUIT	COOLER CHARGE		AIR-COOLED CONDENSER TYPE, SIZE (Qty)*	CONDENSER CHARGE		RECOMMENDED REFRIGERANT PIPE SIZES (in. OD)†	PIPING CHARGE		TOTAL REFRIGERANT CHARGE	
		Lb	Kg		Lb	Kg		Lb	Kg	Lb	Kg
076	A	48	22	09DK 084 (1)	62	28	1 ¹ / ₈	10	5	120	55
	B	48	22		62	28	1 ¹ / ₈	10	5	120	55
086	A	61	28	09DK 084 (1)	62	28	1 ¹ / ₈	10	5	133	61
	B	52	24		62	28	1 ¹ / ₈	10	5	124	57
096	A	75	34	09DK 094 (1)	68	31	1 ¹ / ₈	10	5	153	70
	B	56	25		68	31	1 ¹ / ₈	10	5	134	61
106	A	88	40	09DK 074 (1) and 09DK 044 (1)	82	37	1 ³ / ₈	16	7	186	84
	B	56	25		62	28	1 ³ / ₈	16	7	134	60
	A	88	40	09AZ 102FE (1)	24	11	1 ³ / ₈	16	7	128	58
	B	56	25		18	8	1 ³ / ₈	16	7	90	40
116	A	84	38	09DK 074 (1) and 09DK 054 (1)	82	37	1 ³ / ₈	16	7	182	82
	B	61	28		56	25	1 ³ / ₈	16	7	133	60
	A	84	38	09AZ 112FE (1)	42	19	1 ³ / ₈	16	7	142	64
	B	61	28		42	19	1 ³ / ₈	16	7	119	54
126	A	90	41	09DK 074 (2)	82	37	1 ³ / ₈	16	7	188	85
	B	71	32		82	37	1 ³ / ₈	16	7	169	76
	A	90	41	09AZ 122FE (1)	24	11	1 ³ / ₈	16	7	130	59
	B	71	32		24	11	1 ³ / ₈	16	7	112	50
136	A	99	45	09DK 074 (2)	82	37	1 ³ / ₈	16	7	197	89
	B	71	32		82	37	1 ³ / ₈	16	7	169	76
	A	99	45	09AZ 132FE (1)	57	26	1 ³ / ₈	16	7	172	78
	B	71	32		42	19	1 ³ / ₈	16	7	130	58
146	A	95	43	09DK 084 (2)	124	56	1 ³ / ₈	16	7	235	106
	B	80	36		124	56	1 ³ / ₈	16	7	220	99
	A	95	43	09AZ 142FE (1)	57	26	1 ³ / ₈	16	7	168	76
	B	80	36		57	26	1 ³ / ₈	16	7	153	69
161	A	120	54	09DK 084 (2)	124	56	1 ³ / ₈	16	7	260	117
	B	88	40		124	56	1 ³ / ₈	16	7	228	103
	A	120	54	09AZ 162FE (1)	68	31	1 ³ / ₈	16	7	204	92
	B	88	40		68	31	1 ³ / ₈	16	7	172	78
171	A	95	43	09DK 084 (2)	124	56	1 ³ / ₈	16	7	235	106
	B	112	51		124	56	1 ³ / ₈	16	7	252	114
	A	95	43	09AZ 172FE (1)	68	31	1 ³ / ₈	16	7	179	81
	B	112	51		68	31	1 ³ / ₈	16	7	196	89
186	A	108	49	09DK 084 (2)	124	56	1 ³ / ₈	16	7	248	112
	B	108	49		124	56	1 ³ / ₈	16	7	248	112
	A	108	49	09AZ 182FE (1)	68	31	1 ³ / ₈	16	7	192	87
	B	108	49		68	31	1 ³ / ₈	16	7	192	87
206	A	160	73	09DK 084 (2) and 09DK 094 (1)	272	123	1 ⁵ / ₈	22	10	454	206
	B	108	49		124	56	1 ³ / ₈	16	7	248	112
	A	160	73	09AZ 101FA (1) and 09AZ 91FA (1)	49	22	1 ⁵ / ₈	22	10	231	105
	B	108	49		37	17	1 ³ / ₈	16	7	161	73
246	A	176	80	09DK 094 (3)	272	123	2 ¹ / ₈	38	17	486	220
	B	108	49		136	62	1 ³ / ₈	16	7	260	118
	A	176	80	09AZ 151FA (1) and 09AZ 91FA (1)	113	51	2 ¹ / ₈	38	17	327	148
	B	108	49		37	17	1 ³ / ₈	16	7	161	73
261	A	176	80	09DK 094 (3)	272	123	2 ¹ / ₈	38	17	486	220
	B	108	49		136	62	1 ³ / ₈	16	7	260	118
	A	176	80	09AZ 171FA (1) and 09AZ 91FA (1)	136	62	2 ¹ / ₈	38	17	350	159
	B	108	49		37	17	1 ³ / ₈	16	7	161	73
271	A	176	80	09DK 094 (3)	272	123	2 ¹ / ₈	38	17	486	220
	B	108	49		136	62	1 ³ / ₈	16	7	260	118
	A	176	80	09AZ 181FA (1) and 09AZ 91FA (1)	136	62	2 ¹ / ₈	38	17	350	159
	B	108	49		37	17	1 ³ / ₈	16	7	161	73

*Refer to Carrier's electronic catalog for 09AZ/30HX rating data.

†Based on 25 ft (7.6 m) liquid line.

NOTE: Multiply the liquid line length (in feet) by the factor shown on page 27 for the refrigerant/ft of the tubing. Add base unit charge to liquid line charge to determine approximate refrigerant charge.

TYPICAL 30HXA REFRIGERANT PIPING TO REMOTE CONDENSER (076-096 SIZES SHOWN)

NOTES:

1. Piping shown is for general point-of-connection only and is not intended to show details for a specific installation. Certified field wiring and dimensional drawings are available upon request. The 30HXA units should be installed using certified drawings.
2. Refer to Carrier System Design Manual for details regarding piping techniques.
3. Piping and pressure relief devices are field supplied.
4. Relief valve vent piping per local codes.
5. If unit is equipped with accessory sound enclosure, run lines down to floor and notch bottom of enclosure to clear lines.

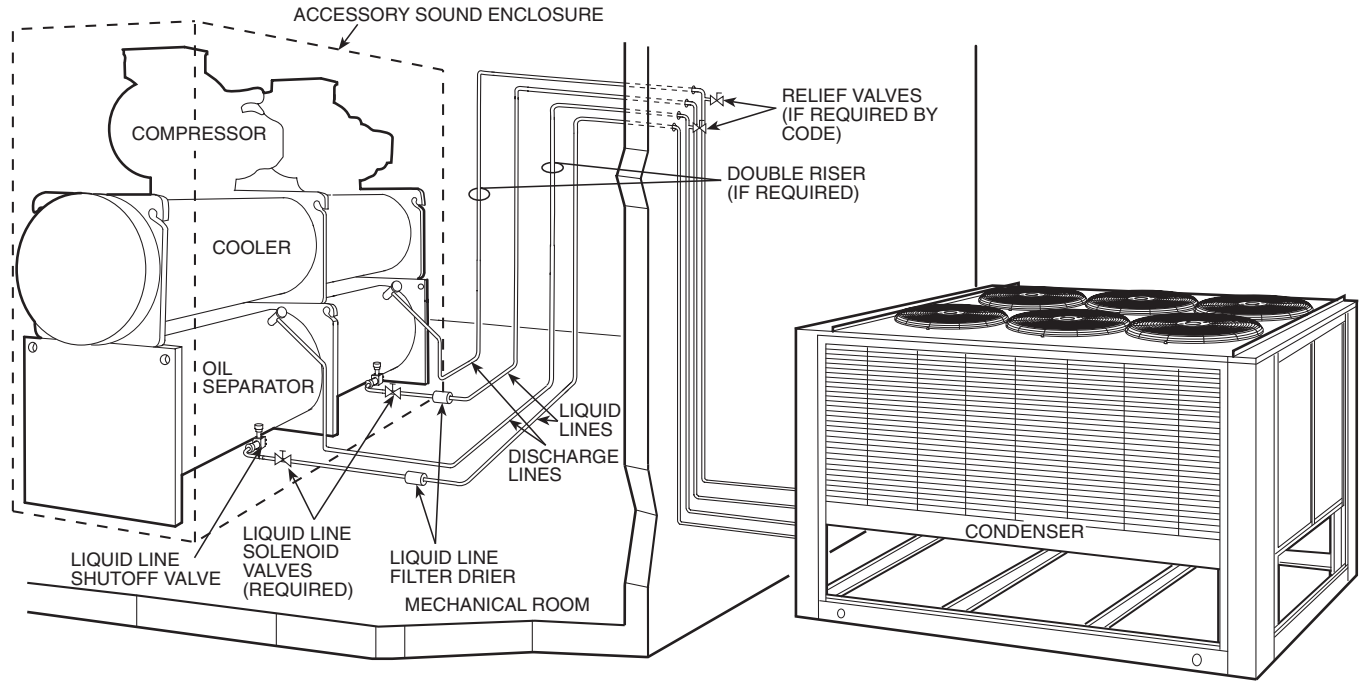

TYPICAL 30HXA REFRIGERANT PIPING TO REMOTE CONDENSER(S) (206-271 SIZES SHOWN)

NOTES:

1. Piping shown is for general point-of-connection only and is not intended to show details for a specific installation. Certified field wiring and dimensional drawings are available upon request. The 30HXA units should be installed using certified drawings.
2. Refer to Carrier System Design Manual for details regarding piping techniques.
3. Piping and pressure relief devices are field supplied.
4. Relief valve vent piping per local codes.
5. If unit is equipped with accessory sound enclosure, run lines down to floor and notch bottom of enclosure to clear lines.

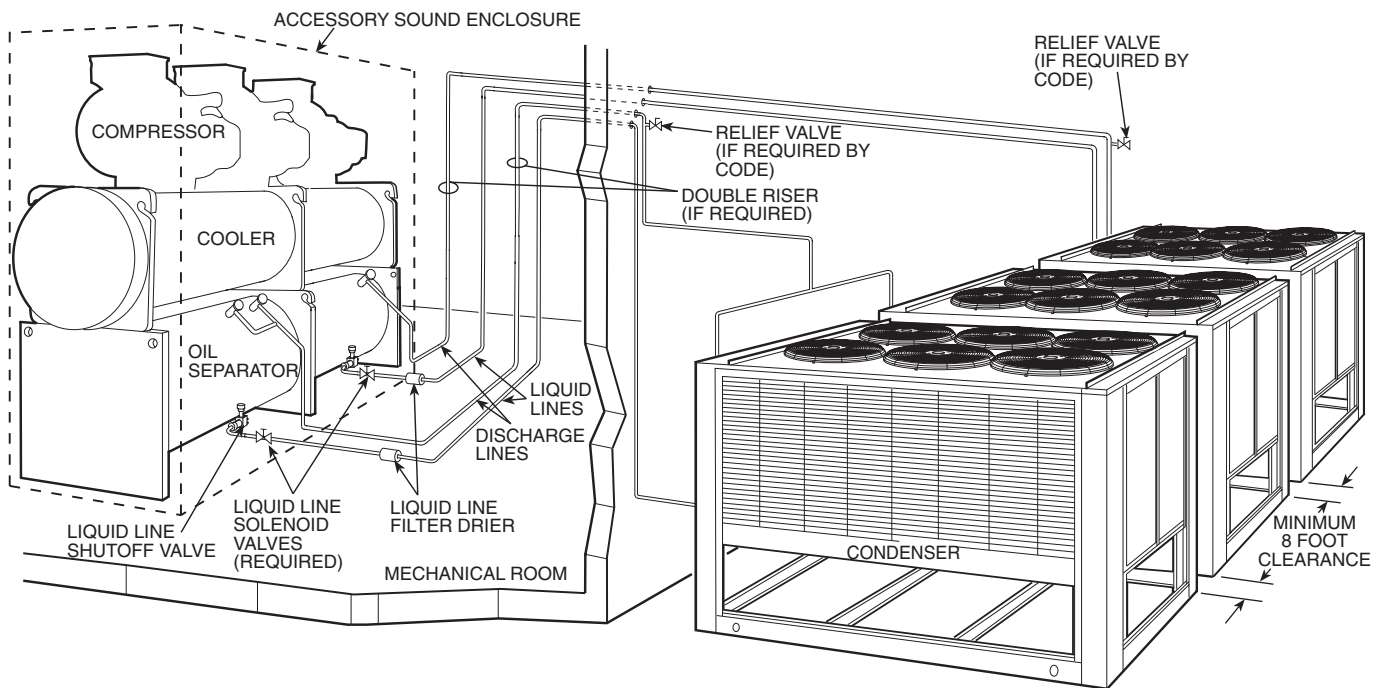

Selection procedure (with example)



Carrier's electronic catalog chiller selection program provides quick, easy selection of Carrier chillers. The program considers specific temperature and flow requirements and other factors, such as fouling and altitude correction. It can also select an air-cooled condenser for the condenserless 30HXA unit to match the required conditions. To select a 30HXA unit, use the electronic catalog or contact your Carrier representative. To select a 30HXC chiller, use the electronic catalog or follow one of the procedures below.

ENGLISH (60 Hz)

I Determine 30HXC unit size and operating conditions required to meet given capacity at given conditions.

Given:

Capacity	175 Tons
Leaving Chilled Water Temp (LCWT)	44 F
Cooler Water Temp Rise	10° F
Condenser Entering Water Temp	85 F
Condenser Water Temp Rise	10° F
Cooling Fouling Factor	0.00010
Condenser Fouling Factor	0.00025

NOTE: For other than 10° F temperature rise, data corrections must be made using the chiller program in the electronic catalog. On some units, a change of controls is also necessary.

II From Cooling Capacities table on page 31 and pressure drop curves on pages 55 and 56, determine operating data for selected unit.

Unit	30HXC186
Capacity	176.9 tons
Compressor Motor Power Input	128.5 kW
Cooler Water Flow	424.2 gpm
Cooler Pressure Drop	12.1 ft of water
Condenser Water Flow	507.7 gpm
Condenser Pressure Drop	16.7 ft of water

SI (50 Hz)

I Determine 30HXC unit size and operating conditions required to meet given capacity at given conditions.

Given:

Capacity	617 kW
Leaving Chilled Water Temp (LCWT)	7 C
Cooler Water Temp Rise	5.6° C
Condenser Entering Water Temp	30 C
Condenser Water Temp Rise	5.6° C
Cooling Fouling Factor	0.01761
Condenser Fouling Factor	0.04403

NOTE: For other than 5.6° C temperature rise, data corrections must be made using the chiller program in the electronic catalog. On some units, a change of controls is also necessary.

II From Cooling Capacities table on page 41 and pressure drop curves on pages 55 and 56, determine operating data for selected unit.

Unit	30HXC186
Capacity	627.0 kW
Compressor Motor Power Input	130.5 kW
Cooler Water Flow	26.9 L/s
Cooler Pressure Drop	36.1 kPa
Condenser Water Flow	32.3 L/s
Condenser Pressure Drop	32.0 kPa

Performance data (cont)



30HXC COOLING CAPACITIES (cont) 60 Hz, ENGLISH (cont)

LCWT (F)	UNIT SIZE 30HXC	CONDENSER ENTERING WATER TEMPERATURE (F)															
		80.0				85.0				90.0				95.0			
		Cap.	Input kW	Cooler Flow Rate (Gpm)	Cond Flow Rate (Gpm)	Cap.	Input kW	Cooler Flow Rate (Gpm)	Cond Flow Rate (Gpm)	Cap.	Input kW	Cooler Flow Rate (Gpm)	Cond Flow Rate (Gpm)	Cap.	Input kW	Cooler Flow Rate (Gpm)	Cond Flow Rate (Gpm)
45.0	076	80.1	51.5	192.1	225.5	76.9	54.2	184.3	219.5	73.5	57.2	176.2	213.5	70.2	60.2	168.3	207.6
	086	88.3	57.8	211.8	249.2	84.7	60.9	203.2	242.8	81.1	64.3	194.5	236.4	77.6	67.7	186.2	230.3
	096	99.8	64.2	239.3	280.9	95.8	67.6	229.7	273.7	91.7	71.5	219.8	266.4	87.8	75.3	210.4	259.6
	106	110.8	71.6	265.7	312.1	106.3	76.0	255.0	304.3	101.6	80.4	243.7	296.1	97.1	86.5	232.9	289.3
	116	120.5	76.2	288.9	338.4	115.8	80.6	277.6	330.1	110.9	85.5	265.9	321.6	105.9	90.4	254.1	313.1
	126	130.5	82.7	312.9	366.5	125.4	87.6	300.6	357.5	120.2	92.9	288.1	348.7	115.0	98.4	275.8	340.0
	136	144.7	92.9	347.0	407.2	139.1	97.8	333.6	397.2	133.4	103.3	319.8	387.1	128.0	108.9	306.9	378.0
	146	154.8	100.3	371.1	436.1	148.8	106.0	356.7	425.6	142.4	112.0	341.5	414.5	136.8	120.7	328.0	406.7
	161	161.8	103.6	388.1	455.2	159.2	112.8	381.8	455.1	156.3	122.9	374.7	454.7	153.7	135.6	368.6	457.0
	171	171.2	110.6	410.6	482.3	168.7	119.7	404.5	482.3	166.0	130.0	398.0	482.6	163.9	141.5	393.0	485.3
	186	182.9	118.4	438.6	515.3	180.2	128.3	432.0	515.4	177.3	139.2	425.2	515.8	175.0	151.0	419.5	518.1
	206	218.6	137.0	524.3	613.1	215.1	147.8	515.8	612.0	211.2	160.5	506.4	611.1	207.7	174.6	498.1	612.2
	246	256.4	160.2	614.9	718.8	252.8	173.3	606.1	718.8	248.4	188.8	595.6	718.7	244.0	205.4	585.1	719.2
	261	265.3	168.1	636.1	745.1	261.5	181.6	627.1	745.2	257.1	197.4	616.5	745.1	253.2	214.2	607.0	746.9
271	275.8	176.1	661.3	775.5	271.9	190.4	651.9	775.7	267.4	206.7	641.2	775.9	263.3	224.1	631.5	777.8	
46.0	076	81.9	51.9	196.4	230.0	78.7	54.3	188.7	224.0	75.2	57.5	180.3	217.8	71.8	60.6	172.2	211.7
	086	90.3	58.2	216.6	254.2	86.7	61.2	208.0	247.7	83.0	64.6	199.0	241.0	79.3	68.0	190.3	234.7
	096	102.0	64.7	244.6	286.5	98.0	67.9	235.1	279.2	93.8	71.8	224.9	271.6	89.7	75.7	215.3	264.6
	106	113.2	72.1	271.6	318.3	108.7	76.2	260.8	310.3	104.0	80.8	249.5	302.1	99.2	85.3	238.0	293.6
	116	123.1	76.7	295.3	345.0	118.4	80.9	284.0	336.6	113.4	85.9	272.1	328.0	108.4	90.8	259.9	319.2
	126	133.3	83.2	319.8	373.7	128.2	87.8	307.6	364.6	122.9	93.3	294.8	355.5	117.6	98.7	282.0	346.5
	136	147.9	93.6	354.7	415.3	142.3	98.2	341.3	405.0	136.4	103.7	327.2	394.7	130.8	109.4	313.8	385.1
	146	158.2	100.8	379.4	444.6	152.1	106.3	364.9	433.9	145.7	112.5	349.6	422.7	139.7	120.7	335.1	413.8
	161	164.7	103.8	395.0	462.2	162.2	112.6	389.0	462.1	159.2	122.7	381.8	461.7	156.3	134.3	374.9	462.4
	171	174.2	110.7	417.9	489.6	171.8	119.6	412.0	489.7	169.0	130.1	405.3	490.0	166.6	141.4	399.6	491.8
	186	186.0	118.6	446.2	523.0	183.4	128.0	440.0	523.1	180.4	139.0	432.8	523.2	177.8	150.8	426.5	524.8
	206	222.5	137.1	533.8	622.7	219.0	148.1	525.4	621.7	215.1	160.5	516.0	620.6	211.3	174.4	506.9	620.7
	246	260.9	160.3	625.7	729.6	257.4	172.7	617.4	729.7	252.9	188.5	606.7	729.5	248.5	205.1	596.0	729.9
	261	269.8	168.5	647.2	756.4	266.3	181.2	638.7	756.5	261.8	197.2	627.9	756.3	257.7	214.3	618.0	757.9
271	280.5	176.4	672.8	787.0	276.8	189.9	663.8	787.2	272.1	206.3	652.7	787.0	268.0	224.1	642.8	789.0	
48.0	076	85.5	52.6	205.2	239.2	82.2	55.0	197.4	233.0	78.7	58.1	188.9	226.6	75.1	61.2	180.3	220.2
	086	94.2	59.1	226.1	264.3	90.7	61.8	217.6	257.6	86.8	65.3	208.2	250.6	83.0	68.8	199.1	243.9
	096	106.4	65.6	255.4	297.8	102.5	68.5	245.9	290.3	98.1	72.5	235.5	282.6	93.9	76.5	225.2	275.1
	106	118.1	73.1	283.5	330.7	113.7	76.8	272.8	322.6	108.9	81.5	261.3	314.3	103.9	86.1	249.4	305.5
	116	128.5	77.6	308.4	358.6	123.8	81.6	297.0	350.0	118.7	86.5	284.8	341.1	113.5	91.6	272.4	332.1
	126	139.1	84.2	333.9	388.3	134.0	88.7	321.5	379.0	128.5	93.9	308.4	369.5	123.0	99.5	295.3	360.1
	136	154.3	94.9	370.3	431.6	148.8	98.9	357.1	421.2	142.7	104.6	342.5	410.5	136.8	110.4	328.2	400.2
	146	165.0	102.1	396.0	462.0	159.0	107.2	381.6	451.0	152.5	113.4	366.1	439.8	145.9	119.8	350.2	428.2
	161	170.4	104.0	408.9	476.1	168.1	112.1	403.5	476.2	165.2	122.4	396.5	476.1	162.0	133.3	388.9	475.7
	171	180.2	111.1	432.4	504.2	177.9	119.8	426.9	504.5	175.1	129.8	420.2	504.5	172.3	141.1	413.4	505.3
	186	192.3	119.0	461.6	538.4	190.0	127.5	455.9	538.6	186.9	138.6	448.6	538.7	184.0	150.5	441.6	539.7
	206	229.3	137.1	550.3	638.9	227.0	148.2	544.8	641.0	223.1	159.9	535.5	639.6	218.9	174.0	525.5	638.9
	246	269.9	160.3	647.6	751.3	266.5	172.8	639.6	751.7	262.3	187.8	629.5	751.7	257.7	204.6	618.4	751.9
	261	279.0	168.9	669.6	778.8	275.7	181.4	661.6	779.2	271.4	196.9	651.2	779.3	266.9	214.1	640.4	780.0
271	289.9	176.7	695.8	810.0	286.5	189.4	687.6	810.4	282.0	205.8	676.8	810.6	277.5	223.6	665.9	811.7	

LEGEND

- Cap.** — Capacity, Tons of Refrigeration
- Cond** — Condenser
- kW** — Compressor Motor Input Power at Rated Voltage
- LCWT** — Leaving Chilled-Water Temperature (F)



30HXC COOLING CAPACITIES (cont)
60 Hz, ENGLISH (cont)

LCWT (F)	UNIT SIZE 30HXC	CONDENSER ENTERING WATER TEMPERATURE (F)															
		80.0				85.0				90.0				95.0			
		Cap.	Input kW	Cooler Flow Rate (Gpm)	Cond Flow Rate (Gpm)	Cap.	Input kW	Cooler Flow Rate (Gpm)	Cond Flow Rate (Gpm)	Cap.	Input kW	Cooler Flow Rate (Gpm)	Cond Flow Rate (Gpm)	Cap.	Input kW	Cooler Flow Rate (Gpm)	Cond Flow Rate (Gpm)
50.0	076	89.0	53.1	213.7	248.0	85.9	55.8	206.1	242.3	82.3	58.5	197.7	235.7	78.6	61.8	188.8	229.0
	086	98.2	59.9	235.8	274.3	94.6	62.7	227.2	267.8	90.7	65.9	217.9	260.6	86.7	69.5	208.3	253.5
	096	110.9	66.3	266.2	309.0	106.9	69.6	256.7	301.8	102.6	73.1	246.4	293.9	98.1	77.2	235.5	285.8
	106	123.1	73.8	295.6	343.2	118.6	77.7	284.9	335.2	113.8	82.1	273.4	326.6	108.8	86.9	261.2	317.8
	116	133.7	78.2	320.9	371.4	129.2	82.6	310.2	363.6	124.1	87.0	298.0	354.6	118.8	92.3	285.2	345.4
	126	144.6	84.8	347.2	401.9	139.9	89.5	335.8	393.8	134.4	94.5	322.7	384.1	128.7	100.3	309.0	374.3
	136	160.9	96.0	386.4	448.3	155.3	100.5	372.8	437.9	149.2	105.5	358.4	426.9	142.9	111.4	343.2	415.7
	146	171.9	103.2	412.8	479.3	166.0	108.3	398.5	468.6	159.5	114.3	383.0	457.2	152.6	120.9	366.5	445.1
	161	176.2	104.0	423.0	490.1	174.0	112.4	417.7	490.5	171.3	122.0	411.2	490.4	168.0	133.0	403.5	490.0
	171	185.5	111.1	445.4	517.0	184.1	119.7	442.0	519.4	181.4	129.5	435.5	519.6	178.4	140.9	428.3	520.0
	186	198.6	119.0	476.9	553.6	196.4	127.9	471.7	554.4	193.6	138.3	464.9	554.7	190.4	150.2	457.2	555.0
	206	236.1	136.8	566.9	655.1	235.1	148.2	564.5	660.5	231.3	160.2	555.4	659.5	227.1	173.7	545.2	658.4
	246	277.4	159.4	666.0	768.9	275.6	173.3	661.8	774.1	271.8	186.9	652.7	774.2	267.1	204.0	641.2	774.2
	261	287.1	168.4	689.4	798.1	285.0	182.1	684.3	802.2	281.1	196.1	675.0	802.4	276.3	213.5	663.3	802.4
	271	298.9	176.3	717.6	831.3	296.1	190.2	711.0	834.2	292.1	205.1	701.2	834.5	287.1	223.0	689.3	834.5
55.0	076	93.0	53.6	223.4	257.8	90.6	56.8	217.7	254.3	87.0	59.4	209.2	247.6	83.2	62.6	200.0	240.7
	086	103.7	60.7	249.3	288.2	100.8	64.1	242.3	283.6	96.9	66.9	233.0	276.3	92.8	70.6	223.0	268.7
	096	116.8	67.0	280.6	323.6	113.9	71.1	273.9	319.6	109.6	74.3	263.4	311.5	103.6	78.1	249.0	299.7
	106	130.0	74.5	312.5	360.2	126.4	79.2	303.7	354.7	121.6	83.1	292.2	345.9	116.4	88.1	279.7	336.9
	116	141.9	78.8	341.0	391.5	138.8	84.2	333.6	387.9	133.6	88.6	321.2	378.5	128.2	93.5	308.0	368.8
	126	154.8	85.6	372.2	427.1	151.6	91.6	364.4	423.4	144.4	96.1	347.1	409.4	138.5	101.7	332.9	398.9
	136	170.5	97.0	409.8	472.1	166.8	102.8	400.9	467.1	160.7	107.5	386.2	455.8	154.2	113.1	370.7	444.2
	146	184.3	104.3	443.0	509.9	179.9	110.9	432.5	503.9	173.4	116.2	416.8	492.0	164.5	122.5	395.3	474.8
	161	184.2	102.8	442.8	508.8	184.3	112.7	442.9	515.5	181.9	121.6	437.1	515.8	178.8	132.5	429.8	515.8
	171	194.5	110.2	467.5	538.2	194.7	120.1	468.1	545.5	192.6	129.3	463.0	546.7	189.6	140.2	455.8	546.9
	186	206.4	118.0	496.0	571.7	206.3	128.3	495.9	578.5	203.8	137.7	489.9	579.0	200.6	149.7	482.2	579.3
	206	245.4	135.7	589.8	676.9	245.6	148.4	590.2	685.9	243.0	160.1	584.1	687.8	238.9	173.0	574.1	686.5
	246	287.8	157.2	691.7	792.6	289.1	172.9	694.9	806.5	286.1	187.1	687.6	808.8	281.7	202.8	677.1	809.0
	261	297.7	166.5	715.6	822.4	299.4	182.3	719.6	837.1	295.8	196.4	710.8	838.0	291.3	212.6	700.2	838.3
	271	309.7	174.4	744.4	856.3	310.9	190.5	747.3	870.1	307.2	204.9	738.4	871.0	302.6	222.1	727.2	871.5
60.0	076	93.0	53.6	223.8	258.0	90.7	56.8	218.2	254.6	87.1	59.4	209.6	247.8	83.3	62.6	200.4	240.9
	086	103.8	60.7	249.8	288.5	100.9	64.1	242.8	283.9	97.0	66.9	233.4	276.5	92.9	70.6	223.4	269.0
	096	116.9	67.0	281.1	323.9	112.7	70.8	271.1	316.5	108.4	74.0	260.7	308.3	103.7	78.1	249.5	300.0
	106	130.1	74.5	313.0	360.5	126.5	79.2	304.4	355.1	121.7	83.1	292.7	346.3	115.6	87.9	278.0	334.8
	116	142.0	78.8	341.6	391.9	139.0	84.3	334.3	388.3	132.1	88.3	317.9	374.7	126.7	93.4	304.7	365.1
	126	153.6	85.6	369.5	424.1	150.2	91.5	361.2	419.9	144.6	96.2	347.9	409.8	138.7	101.7	333.6	399.4
	136	170.7	97.0	410.6	472.5	167.0	102.8	401.7	467.6	160.9	107.5	387.1	456.3	152.5	112.8	366.8	439.7
	146	184.5	104.3	443.8	510.4	178.1	110.5	428.5	499.4	171.7	115.7	413.0	487.6	164.7	122.5	396.1	475.3
	161	183.1	103.0	440.6	506.3	182.8	112.6	439.7	512.0	180.4	121.4	433.9	512.1	177.3	132.6	426.5	512.2
	171	193.5	110.4	465.6	536.0	193.7	120.2	466.0	543.1	191.3	129.2	460.3	543.5	188.3	140.3	452.9	543.7
	186	206.5	118.0	496.8	572.0	206.5	128.3	496.7	579.0	204.0	137.7	490.8	579.5	200.8	149.7	483.0	579.8
	206	245.6	135.7	590.7	677.3	245.7	148.4	591.1	686.3	243.2	160.1	585.1	688.3	239.0	173.0	575.0	687.0
	246	288.0	157.1	692.7	793.0	289.3	172.9	696.0	806.9	286.3	187.1	688.8	809.4	278.8	203.1	670.7	802.1
	261	297.9	166.5	716.6	822.8	299.6	182.3	720.6	837.5	296.0	196.4	712.1	838.6	291.6	212.5	701.4	838.9
	271	309.9	174.4	745.5	856.8	311.2	190.5	748.6	870.7	307.5	204.9	739.7	871.7	302.9	222.0	728.5	872.1

LEGEND

- Cap.** — Capacity, Tons of Refrigeration
- Cond** — Condenser
- kW** — Compressor Motor Input Power at Rated Voltage
- LCWT** — Leaving Chilled-Water Temperature (F)

Performance data (cont)



30HXC COOLING CAPACITIES (cont) 60 Hz, SI

LCWT (C)	UNIT SIZE 30HXC	CONDENSER ENTERING WATER TEMPERATURE (C)											
		25				30				35			
		Cap.	Input kW	Cooler Flow Rate (L/s)	Cond Flow Rate (L/s)	Cap.	Input kW	Cooler Flow Rate (L/s)	Cond Flow Rate (L/s)	Cap.	Input kW	Cooler Flow Rate (L/s)	Cond Flow Rate (L/s)
4.0	076	253.3	48.2	10.9	12.8	234.3	53.2	10.1	12.2	219.0	58.9	9.4	11.8
	086	279.3	54.2	12.0	14.2	258.8	59.8	11.1	13.6	242.8	66.3	10.4	13.1
	096	315.5	60.1	13.5	16.0	292.4	66.5	12.5	15.3	274.3	73.8	11.8	14.8
	106	350.4	67.5	15.0	17.8	323.9	74.8	13.9	17.0	304.3	83.6	13.1	16.5
	116	380.9	71.7	16.3	19.3	352.8	79.7	15.1	18.4	330.6	88.9	14.2	17.9
	126	412.5	77.8	17.7	20.9	382.6	86.7	16.4	20.0	359.0	96.8	15.4	19.4
	136	457.2	87.4	19.6	23.2	425.0	96.5	18.2	22.2	400.3	107.0	17.2	21.6
	146	489.2	94.6	21.0	24.9	454.2	104.7	19.5	23.8	428.3	116.7	18.4	23.2
	161	516.5	99.2	22.2	26.2	500.1	115.5	21.5	26.2	494.5	135.8	21.2	26.8
	171	547.2	105.5	23.5	27.8	532.8	122.4	22.9	27.9	526.6	142.9	22.6	28.5
	186	584.8	113.6	25.1	29.8	569.1	131.4	24.4	29.8	563.8	153.4	24.2	30.5
	206	697.8	130.3	29.9	35.3	676.3	150.8	29.0	35.2	663.7	175.8	28.5	35.7
	246	819.9	152.7	35.2	41.5	795.2	178.2	34.1	41.5	782.7	208.6	33.6	42.2
	261	848.6	160.3	36.4	43.0	824.6	186.1	35.4	43.0	814.2	217.4	34.9	43.9
271	882.7	168.4	37.9	44.8	858.2	195.3	36.8	44.9	848.5	228.0	36.4	45.8	
5.0	076	264.0	48.6	11.3	13.3	244.2	53.7	10.5	12.7	227.2	59.3	9.8	12.2
	086	291.1	54.7	12.5	14.7	269.7	60.4	11.6	14.1	251.8	66.7	10.8	13.6
	096	328.8	60.6	14.1	16.6	304.8	67.1	13.1	15.8	284.5	74.3	12.2	15.3
	106	365.2	67.9	15.7	18.5	337.9	75.5	14.5	17.6	315.4	84.1	13.5	17.0
	116	396.9	72.2	17.0	20.0	368.2	80.4	15.8	19.1	342.8	89.4	14.7	18.4
	126	429.7	78.5	18.4	21.7	399.0	87.3	17.1	20.7	372.1	97.3	16.0	20.0
	136	476.5	88.0	20.5	24.1	442.8	97.2	19.0	23.0	415.1	107.6	17.8	22.3
	146	509.7	95.3	21.9	25.8	472.9	105.4	20.3	24.6	443.9	117.3	19.1	23.9
	161	534.4	98.8	22.9	27.0	517.4	115.3	22.2	27.0	508.5	135.2	21.8	27.4
	171	565.5	105.2	24.3	28.6	549.8	121.8	23.6	28.6	541.4	142.1	23.2	29.1
	186	604.6	113.2	26.0	30.6	587.8	131.1	25.2	30.6	579.4	152.8	24.9	31.2
	206	721.6	130.2	31.0	36.3	699.3	150.2	30.0	36.2	683.0	174.9	29.3	36.5
	246	847.2	152.7	36.4	42.6	822.6	177.7	35.3	42.6	804.8	207.6	34.5	43.1
	261	877.0	159.8	37.6	44.2	852.1	185.4	36.6	44.2	836.9	216.1	35.9	44.8
271	912.2	167.9	39.2	46.0	886.5	194.8	38.1	46.1	872.0	226.9	37.4	46.8	
6.0	076	274.8	49.3	11.8	13.8	254.6	54.2	10.9	13.2	235.6	59.7	10.1	12.6
	086	303.0	55.3	13.0	15.3	281.0	60.9	12.1	14.6	261.1	67.2	11.2	14.0
	096	342.1	61.5	14.7	17.2	317.5	67.7	13.6	16.4	295.0	74.8	12.7	15.8
	106	380.0	68.6	16.3	19.1	352.4	76.2	15.1	18.3	326.9	86.5	14.0	17.6
	116	413.0	73.0	17.7	20.7	383.9	81.0	16.5	19.8	355.4	90.5	15.3	19.0
	126	447.2	79.1	19.2	22.4	415.9	88.0	17.9	21.5	385.7	98.2	16.6	20.6
	136	495.8	89.2	21.3	24.9	461.3	98.0	19.8	23.8	430.3	108.1	18.5	22.9
	146	530.4	96.2	22.8	26.7	493.0	106.3	21.2	25.5	460.1	117.8	19.8	24.6
	161	551.9	98.9	23.7	27.8	535.3	115.1	23.0	27.7	522.7	134.7	22.5	28.0
	171	584.0	105.3	25.1	29.4	568.2	121.7	24.4	29.4	556.5	141.7	23.9	29.7
	186	624.0	113.3	26.8	31.4	607.0	130.8	26.1	31.4	595.3	152.0	25.6	31.8
	206	745.8	130.4	32.0	37.4	723.5	150.2	31.1	37.3	703.4	174.7	30.2	37.4
	246	874.5	153.0	37.6	43.8	850.6	177.1	36.5	43.8	827.4	207.0	35.5	44.1
	261	904.8	160.3	38.9	45.4	880.4	184.9	37.8	45.4	860.1	215.0	36.9	45.8
271	940.9	168.5	40.4	47.3	915.5	194.2	39.3	47.3	895.9	225.6	38.5	47.8	

LEGEND

- Cap. — Capacity, kW
- Cond — Condenser
- kW — Compressor Motor Input Power at Rated Voltage
- LCWT — Leaving Chilled-Water Temperature (C)



30HXC COOLING CAPACITIES (cont)
60 Hz, SI (cont)

LCWT (C)	UNIT SIZE 30HXC	CONDENSER ENTERING WATER TEMPERATURE (C)											
		25				30				35			
		Cap.	Input kW	Cooler Flow Rate (L/s)	Cond Flow Rate (L/s)	Cap.	Input kW	Cooler Flow Rate (L/s)	Cond Flow Rate (L/s)	Cap.	Input kW	Cooler Flow Rate (L/s)	Cond Flow Rate (L/s)
7.0	076	285.8	50.0	12.3	14.3	265.5	54.7	11.4	13.7	244.7	60.1	10.5	13.0
	086	315.0	56.1	13.5	15.8	292.7	61.5	12.6	15.1	270.7	67.6	11.6	14.4
	096	355.7	62.3	15.3	17.8	330.9	68.3	14.2	17.0	305.9	75.2	13.1	16.2
	106	395.0	69.4	17.0	19.8	367.3	76.8	15.8	18.9	338.8	86.9	14.6	18.1
	116	429.4	73.8	18.5	21.5	400.0	81.5	17.2	20.5	369.2	90.3	15.9	19.6
	126	465.0	80.0	20.0	23.3	433.2	88.5	18.6	22.2	400.9	98.3	17.2	21.3
	136	515.5	90.3	22.2	25.8	480.7	98.8	20.7	24.7	446.1	108.7	19.2	23.6
	146	551.5	97.2	23.7	27.7	514.0	107.1	22.1	26.5	477.0	120.3	20.5	25.4
	161	569.5	99.1	24.5	28.5	553.9	114.9	23.8	28.5	537.3	136.0	23.1	28.7
	171	602.5	105.7	25.9	30.2	587.0	121.7	25.2	30.2	572.7	141.5	24.6	30.4
	186	643.4	113.6	27.7	32.3	627.0	130.5	26.9	32.3	611.5	151.2	26.3	32.5
	206	767.9	130.7	33.0	38.3	748.2	150.1	32.2	38.3	725.6	174.6	31.2	38.4
	246	902.1	153.1	38.8	45.0	879.4	176.5	37.8	45.0	852.2	205.5	36.6	45.1
	261	933.1	160.9	40.1	46.7	910.0	184.8	39.1	46.7	884.3	214.3	38.0	46.8
271	970.1	168.8	41.7	48.6	946.0	193.8	40.7	48.6	920.3	224.4	39.6	48.8	
8.0	076	297.0	50.5	12.8	14.8	276.7	55.1	11.9	14.2	254.9	60.7	11.0	13.5
	086	327.4	56.9	14.1	16.4	305.0	62.0	13.1	15.7	281.6	68.2	12.1	14.9
	096	369.8	63.0	15.9	18.5	344.8	68.8	14.8	17.6	318.5	75.9	13.7	16.8
	106	410.5	70.2	17.7	20.5	382.6	77.3	16.5	19.6	352.2	85.5	15.1	18.7
	116	446.2	74.5	19.2	22.2	416.7	82.0	17.9	21.3	384.6	90.9	16.5	20.3
	126	482.7	80.8	20.8	24.0	451.2	89.0	19.4	23.1	417.2	98.9	17.9	22.0
	136	535.7	91.4	23.0	26.8	500.7	99.4	21.5	25.6	464.2	109.6	20.0	24.5
	146	573.0	98.2	24.6	28.6	535.4	107.7	23.0	27.4	495.5	120.4	21.3	26.3
	161	587.4	99.2	25.3	29.3	572.5	114.5	24.6	29.3	553.3	133.5	23.8	29.3
	171	620.0	106.1	26.7	31.0	606.4	121.7	26.1	31.1	589.7	141.4	25.4	31.2
	186	663.1	113.8	28.5	33.1	647.6	130.1	27.8	33.2	629.4	150.7	27.1	33.3
	206	788.8	130.7	33.9	39.2	773.3	150.4	33.3	39.4	748.2	174.3	32.2	39.3
	246	927.6	152.7	39.9	46.1	908.8	175.7	39.1	46.3	880.2	205.0	37.8	46.3
	261	961.0	161.1	41.3	47.9	940.1	184.3	40.4	48.0	912.6	214.3	39.2	48.1
271	999.8	168.9	43.0	49.9	977.1	193.0	42.0	49.9	949.1	224.0	40.8	50.0	
9.0	076	307.1	50.9	13.2	15.3	288.1	55.6	12.4	14.7	265.4	61.3	11.4	13.9
	086	339.3	57.5	14.6	16.9	317.5	62.5	13.7	16.2	293.1	68.9	12.6	15.4
	096	382.7	63.6	16.5	19.0	358.9	69.3	15.4	18.3	331.5	76.6	14.3	17.4
	106	425.6	70.8	18.3	21.2	398.2	77.7	17.1	20.3	367.1	86.2	15.8	19.3
	116	461.5	74.9	19.9	22.9	433.7	82.6	18.7	22.0	401.0	91.7	17.3	21.0
	126	499.3	81.2	21.5	24.8	469.5	89.7	20.2	23.9	434.6	99.6	18.7	22.8
	136	554.9	92.1	23.9	27.6	521.4	100.0	22.4	26.5	483.1	110.5	20.8	25.3
	146	593.6	99.0	25.5	29.6	557.2	108.4	24.0	28.4	515.4	119.9	22.2	27.1
	161	604.3	99.0	26.0	30.0	591.4	114.0	25.4	30.1	571.9	133.3	24.6	30.1
	171	636.5	105.9	27.4	31.7	625.9	121.6	26.9	31.9	607.9	141.1	26.2	31.9
	186	681.5	113.6	29.3	33.9	668.5	129.6	28.8	34.1	649.4	150.5	27.9	34.1
	206	810.0	130.3	34.8	40.1	798.6	150.5	34.4	40.5	772.8	174.0	33.2	40.4
	246	950.1	151.7	40.9	47.0	937.9	175.5	40.3	47.5	909.5	204.6	39.1	47.5
	261	983.6	160.4	42.3	48.8	970.2	184.0	41.7	49.3	941.7	214.0	40.5	49.3
271	1023.9	168.1	44.1	50.9	1008.4	192.0	43.4	51.2	979.1	223.6	42.1	51.3	

LEGEND

- Cap. — Capacity, kW
- Cond — Condenser
- kW — Compressor Motor Input Power at Rated Voltage
- LCWT — Leaving Chilled-Water Temperature (C)

Performance data (cont)



30HXC COOLING CAPACITIES (cont) 60 Hz, SI (cont)

LCWT (C)	UNIT SIZE 30HXC	CONDENSER ENTERING WATER TEMPERATURE (C)											
		25				30				35			
		Cap.	Input kW	Cooler Flow Rate (L/s)	Cond Flow Rate (L/s)	Cap.	Input kW	Cooler Flow Rate (L/s)	Cond Flow Rate (L/s)	Cap.	Input kW	Cooler Flow Rate (L/s)	Cond Flow Rate (L/s)
10.0	076	316.8	51.2	13.6	15.7	299.5	56.3	12.9	15.2	276.5	61.8	11.9	14.4
	086	350.6	57.9	15.1	17.4	330.2	63.2	14.2	16.8	305.0	69.5	13.1	16.0
	096	394.6	63.9	17.0	19.6	373.1	70.2	16.1	18.9	345.0	77.2	14.8	18.0
	106	439.6	71.1	18.9	21.8	414.1	78.4	17.8	21.0	382.5	87.0	16.5	20.0
	116	476.2	75.1	20.5	23.5	450.9	83.4	19.4	22.8	417.7	92.3	18.0	21.8
	126	515.7	81.5	22.2	25.5	488.1	90.5	21.0	24.7	452.5	100.4	19.5	23.6
	136	572.0	92.6	24.6	28.4	541.9	101.3	23.3	27.5	502.6	111.4	21.6	26.2
	146	613.8	99.6	26.4	30.5	579.2	109.5	24.9	29.4	536.8	120.9	23.1	28.1
	161	618.4	98.4	26.6	30.6	610.2	114.0	26.3	30.9	590.9	133.0	25.4	30.9
	171	652.7	105.5	28.1	32.4	645.5	121.6	27.8	32.7	627.4	140.9	27.0	32.8
	186	697.0	113.0	30.0	34.6	689.2	129.6	29.7	35.0	669.6	150.2	28.8	35.0
	206	830.5	129.5	35.7	41.0	824.3	150.5	35.5	41.6	798.6	173.7	34.4	41.5
	246	971.5	150.3	41.8	47.9	966.9	175.9	41.6	48.8	939.2	204.0	40.4	48.8
	261	1005.3	159.3	43.3	49.7	999.8	184.7	43.0	50.6	971.6	213.5	41.8	50.6
271	1046.2	166.9	45.0	51.8	1038.9	192.9	44.7	52.6	1009.6	223.0	43.5	52.6	
13.0	076	333.2	51.5	14.4	16.4	318.8	57.5	13.7	16.1	295.3	62.7	12.7	15.3
	086	371.6	58.5	16.0	18.4	351.4	64.7	15.1	17.8	322.0	70.4	13.9	16.7
	096	414.1	64.3	17.8	20.4	396.1	71.7	17.1	20.0	367.5	78.3	15.8	19.0
	106	462.7	71.3	19.9	22.8	441.4	80.0	19.0	22.3	404.1	87.9	17.4	21.0
	116	503.0	75.3	21.7	24.7	482.5	85.1	20.8	24.3	444.8	93.3	19.2	23.0
	126	549.3	81.8	23.7	27.0	523.1	92.4	22.5	26.3	486.7	101.6	21.0	25.1
	136	604.3	93.2	26.0	29.8	580.0	103.7	25.0	29.2	540.2	113.0	23.3	27.9
	146	653.5	99.9	28.2	32.2	626.2	111.9	27.0	31.5	577.9	122.5	24.9	29.9
	161	644.6	96.7	27.8	31.7	644.8	114.5	27.8	32.4	627.2	132.5	27.0	32.4
	171	680.9	104.1	29.3	33.5	683.3	122.1	29.4	34.4	666.1	140.3	28.7	34.4
	186	721.9	111.6	31.1	35.6	722.7	130.3	31.1	36.4	704.3	149.7	30.3	36.5
	206	867.6	128.6	37.4	42.6	868.0	150.8	37.4	43.5	840.0	173.0	36.2	43.3
	246	1005.8	148.1	43.3	49.3	1012.4	176.1	43.6	50.8	986.6	203.0	42.5	50.8
	261	1035.5	157.4	44.6	51.0	1040.5	185.1	44.8	52.4	1014.1	212.8	43.7	52.4
271	1085.7	164.3	46.8	53.4	1092.2	193.4	47.1	54.9	1065.4	222.0	45.9	55.0	
16.0	076	330.1	51.4	14.2	16.3	315.2	57.3	13.6	15.9	291.7	62.6	12.6	15.1
	086	368.2	58.4	15.9	18.2	350.8	64.6	15.1	17.7	325.2	70.5	14.0	16.9
	096	414.4	64.3	17.9	20.4	396.5	71.7	17.1	20.0	363.2	78.1	15.7	18.8
	106	461.4	71.3	19.9	22.8	439.8	79.9	19.0	22.2	408.0	88.0	17.6	21.2
	116	503.5	75.2	21.7	24.7	483.2	85.1	20.8	24.3	449.3	93.5	19.4	23.2
	126	549.5	81.7	23.7	27.0	522.1	92.4	22.5	26.3	485.7	101.6	20.9	25.1
	136	604.9	93.2	26.1	29.8	580.7	103.7	25.0	29.2	540.9	113.0	23.3	27.9
	146	653.8	100.0	28.2	32.2	626.6	111.9	27.0	31.5	576.7	122.4	24.9	29.9
	161	644.7	96.7	27.8	31.7	645.0	114.5	27.8	32.4	627.4	132.5	27.1	32.5
	171	680.8	104.2	29.4	33.5	682.8	122.0	29.4	34.4	665.5	140.3	28.7	34.4
	186	725.8	111.4	31.3	35.8	728.0	130.3	31.4	36.7	703.9	149.7	30.4	36.5
	206	861.0	128.7	37.1	42.3	861.3	150.9	37.1	43.2	837.8	173.1	36.1	43.2
	246	1007.7	148.2	43.5	49.4	1014.1	176.0	43.7	50.9	988.3	202.9	42.6	50.9
	261	1041.2	157.0	44.9	51.2	1048.1	185.2	45.2	52.7	1022.1	212.6	44.1	52.7
271	1083.0	164.5	46.7	53.3	1088.6	193.4	46.9	54.8	1061.6	222.1	45.8	54.8	

LEGEND

- Cap. — Capacity, kW
- Cond — Condenser
- kW — Compressor Motor Input Power at Rated Voltage
- LCWT — Leaving Chilled-Water Temperature (C)



30HXC COOLING CAPACITIES (cont)
50 Hz, ENGLISH

LCWT (F)	UNIT SIZE 30HXC	CONDENSER ENTERING WATER TEMPERATURE (F)															
		80.0				85.0				90.0				95.0			
		Cap.	Input kW	Cooler Flow Rate (Gpm)	Cond Flow Rate (Gpm)	Cap.	Input kW	Cooler Flow Rate (Gpm)	Cond Flow Rate (Gpm)	Cap.	Input kW	Cooler Flow Rate (Gpm)	Cond Flow Rate (Gpm)	Cap.	Input kW	Cooler Flow Rate (Gpm)	Cond Flow Rate (Gpm)
40.0	076	70.1	48.8	167.8	199.6	67.1	51.6	160.6	194.3	64.3	54.5	153.8	189.5	62.0	57.8	148.4	186.3
	086	78.5	55.9	187.9	224.4	75.5	59.2	180.7	219.3	72.5	62.6	173.6	214.5	70.0	66.3	167.6	211.0
	096	89.4	62.7	214.1	255.0	86.1	66.7	206.2	249.8	82.9	70.6	198.4	244.5	80.0	74.9	191.6	240.6
	106	98.1	69.4	234.8	280.0	93.8	73.6	224.6	272.6	90.1	78.0	215.8	266.8	87.4	83.3	209.3	263.8
	116	107.8	74.6	258.1	306.8	103.6	79.4	247.9	299.8	99.2	84.0	237.5	292.4	96.1	89.6	230.0	288.7
	126	117.7	81.9	281.7	335.1	113.1	87.2	270.7	327.6	108.5	92.4	259.7	320.1	105.0	98.4	251.3	315.7
	136	130.4	91.5	312.2	371.8	125.5	96.9	300.5	363.7	120.8	102.3	289.3	356.2	117.0	108.5	280.1	351.2
	146	138.1	98.0	330.6	394.5	132.3	103.5	316.8	384.4	127.7	109.8	305.6	377.4	124.0	117.0	296.8	373.4
	161	147.7	104.3	353.6	421.5	145.0	113.4	347.1	421.1	143.2	123.7	342.8	423.6	142.5	135.5	341.1	429.7
	171	156.0	110.4	373.3	445.3	153.5	119.8	367.5	445.7	151.9	130.3	363.7	448.9	151.2	142.1	361.9	454.9
	186	167.2	119.2	400.1	477.8	164.6	129.2	394.1	478.4	162.9	140.3	390.1	481.8	162.3	153.1	388.5	488.7
	206	199.4	136.3	477.4	566.4	196.1	148.4	469.4	566.3	193.5	161.6	463.3	569.0	191.9	176.1	459.4	574.8
	246	234.4	160.7	561.2	666.1	230.4	174.9	551.7	666.0	226.7	190.1	542.8	667.2	225.5	208.1	539.7	676.1
	261	242.1	168.0	579.6	689.2	238.2	182.4	570.2	689.4	235.0	197.9	562.5	691.9	233.9	216.2	560.0	701.7
271	252.3	176.9	603.9	719.2	248.3	191.9	594.5	719.8	245.2	208.3	587.1	723.3	244.2	227.5	584.6	733.6	
42.0	076	73.4	49.2	175.9	208.0	70.3	52.1	168.3	202.3	67.2	55.0	161.0	197.0	64.6	58.2	154.7	192.8
	086	82.0	56.3	196.5	233.0	78.9	59.8	189.0	228.0	75.7	63.2	181.4	222.6	73.0	66.9	174.8	218.5
	096	93.4	63.0	223.7	264.7	90.1	67.2	215.7	259.5	86.5	71.2	207.3	253.7	83.4	75.5	199.8	249.1
	106	102.7	69.9	246.0	291.5	98.3	74.2	235.6	283.9	93.9	78.4	225.0	276.1	90.9	84.4	217.7	272.9
	116	112.7	75.0	269.9	318.7	108.4	80.0	259.7	311.9	103.9	84.8	248.8	304.2	99.9	90.6	239.4	298.7
	126	122.9	82.2	294.5	348.0	118.3	87.8	283.5	340.7	113.5	93.2	271.9	332.7	109.2	99.5	261.6	326.6
	136	136.3	92.0	326.4	386.3	131.3	97.6	314.4	378.1	126.2	103.1	302.3	369.7	121.8	109.2	291.9	363.3
	146	144.6	98.7	346.5	410.6	138.7	104.4	332.2	400.2	133.1	110.4	318.9	391.0	128.9	117.5	308.8	385.6
	161	153.4	103.9	367.4	435.0	150.6	113.2	360.8	434.5	148.0	123.0	354.4	434.7	146.9	134.8	352.0	440.1
	171	161.9	110.2	387.8	459.4	159.3	119.6	381.6	459.5	157.1	129.9	376.4	461.2	155.9	141.6	373.4	465.9
	186	173.5	118.8	415.5	492.7	170.7	128.8	408.8	492.7	168.2	139.5	403.0	494.0	167.3	152.3	400.7	500.3
	206	206.9	136.6	495.7	584.6	203.6	148.1	487.7	584.3	200.3	160.9	479.9	585.1	198.0	175.3	474.3	589.0
	246	243.4	159.9	583.1	687.2	239.2	174.3	573.1	686.8	235.1	189.4	563.2	687.0	232.6	207.3	557.3	692.9
	261	251.3	167.4	602.0	710.9	247.1	181.9	591.9	710.5	243.3	197.3	582.8	711.7	241.2	215.1	577.8	718.5
271	261.8	176.1	627.1	741.7	257.4	191.2	616.7	741.3	253.6	207.2	607.5	742.8	251.7	226.1	603.0	750.9	
44.0	076	76.8	49.9	184.2	216.5	73.6	52.6	176.5	210.7	70.4	55.6	168.7	204.9	67.3	58.6	161.3	199.6
	086	85.6	56.6	205.1	241.8	82.5	60.2	197.7	236.8	79.2	63.7	189.8	231.3	76.0	67.3	182.1	226.0
	096	97.4	63.5	233.6	274.8	94.0	67.6	225.3	269.3	90.4	71.8	216.7	263.6	86.8	75.9	208.2	257.7
	106	107.4	70.5	257.5	303.2	103.0	74.8	246.9	295.6	98.4	79.2	235.9	287.5	94.4	86.5	226.3	282.6
	116	117.6	75.5	281.9	330.9	113.3	80.4	271.7	324.0	108.8	85.5	260.7	316.4	104.0	90.4	249.4	308.5
	126	128.2	82.9	307.4	361.2	123.7	88.3	296.6	354.0	118.7	93.9	284.6	345.8	113.8	99.4	272.8	337.7
	136	142.3	92.5	341.0	401.1	137.2	98.3	328.8	392.8	131.9	104.0	316.2	384.0	126.8	109.8	304.1	375.8
	146	151.2	99.5	362.5	427.1	145.2	105.3	348.2	416.6	139.0	111.2	333.3	405.7	134.0	119.1	321.2	398.9
	161	159.1	103.5	381.4	448.6	156.4	113.0	375.0	448.4	153.5	122.9	367.9	448.0	151.9	136.4	364.1	453.1
	171	167.8	110.3	402.1	473.7	165.2	119.4	396.0	473.6	162.5	129.5	389.6	474.0	160.8	140.9	385.4	477.4
	186	179.8	118.4	431.0	507.8	176.9	128.5	424.2	507.7	174.2	139.3	417.6	508.4	172.3	151.4	413.1	512.0
	206	214.5	136.7	514.1	602.9	211.2	147.5	506.4	602.4	207.6	160.5	497.7	602.4	204.8	174.8	490.9	605.2
	246	252.2	159.9	604.5	708.4	248.3	173.7	595.2	708.3	244.0	189.1	584.9	708.2	239.9	205.6	575.1	709.5
	261	260.3	167.5	624.0	732.7	256.4	181.5	614.5	732.7	252.1	197.1	604.4	732.9	248.6	213.8	595.9	735.6
271	271.2	175.8	650.0	764.2	267.0	190.8	640.0	764.2	262.7	207.0	629.9	764.8	259.4	224.8	621.7	768.5	

LEGEND

- Cap.** — Capacity, Tons of Refrigeration
Cond — Condenser
kW — Compressor Motor Input Power at Rated Voltage
LCWT — Leaving Chilled-Water Temperature (F)

Performance data (cont)



30HXC COOLING CAPACITIES (cont) 50 Hz, ENGLISH (cont)

LCWT (F)	UNIT SIZE 30HXC	CONDENSER ENTERING WATER TEMPERATURE (F)															
		80.0				85.0				90.0				95.0			
		Cap.	Input kW	Cooler Flow Rate (Gpm)	Cond Flow Rate (Gpm)	Cap.	Input kW	Cooler Flow Rate (Gpm)	Cond Flow Rate (Gpm)	Cap.	Input kW	Cooler Flow Rate (Gpm)	Cond Flow Rate (Gpm)	Cap.	Input kW	Cooler Flow Rate (Gpm)	Cond Flow Rate (Gpm)
45.0	076	78.5	50.3	188.3	220.9	75.3	52.8	180.7	215.0	72.0	55.8	172.6	209.0	68.8	58.9	164.9	203.4
	086	87.4	56.8	209.5	246.3	84.2	60.3	202.0	241.2	80.9	64.0	194.1	235.7	77.6	67.5	186.1	230.1
	096	99.5	64.0	238.6	280.0	96.0	67.8	230.2	274.3	92.4	72.1	221.6	268.6	88.7	76.2	212.6	262.3
	106	109.8	70.8	263.3	309.2	105.3	75.1	252.6	301.4	100.7	79.6	241.5	293.3	96.3	85.7	230.9	286.7
	116	120.1	75.8	288.0	337.1	115.8	80.5	277.8	330.1	111.3	85.7	266.8	322.7	106.4	90.7	255.2	314.4
	126	131.0	83.1	314.0	367.9	126.4	88.5	303.1	360.7	121.4	94.2	291.2	352.6	116.4	99.8	279.0	344.2
	136	145.3	93.2	348.4	408.8	140.2	98.6	336.2	400.2	134.8	104.4	323.4	391.4	129.6	110.3	310.7	382.7
	146	154.6	100.0	370.7	435.5	148.6	105.6	356.3	424.9	142.3	111.7	341.1	413.8	136.8	120.4	327.9	406.5
	161	161.9	103.6	388.3	455.5	159.3	112.8	382.1	455.4	156.4	122.8	375.0	454.9	154.3	136.2	369.9	458.7
	171	170.7	110.3	409.4	480.9	168.2	119.2	403.4	480.8	165.5	129.4	396.8	481.1	163.4	140.7	391.9	483.7
	186	182.9	118.4	438.6	515.3	180.2	128.3	432.0	515.4	177.3	139.2	425.2	515.8	175.0	151.0	419.5	518.1
	206	218.3	136.6	523.5	612.1	215.1	147.6	515.8	611.8	211.5	160.4	507.1	611.7	208.3	174.6	499.5	613.5
	246	256.6	160.1	615.2	719.1	252.9	173.2	606.4	719.1	248.5	188.8	595.9	718.9	244.1	205.3	585.4	719.5
	261	264.8	167.8	635.0	743.8	261.1	181.1	626.0	743.8	256.6	196.8	615.4	743.6	252.7	213.5	606.0	745.4
	271	275.8	176.1	661.3	775.5	271.9	190.4	651.9	775.7	267.4	206.7	641.2	775.8	263.3	224.1	631.5	777.8
46.0	076	80.3	50.6	192.5	225.3	77.1	53.0	184.9	219.4	73.7	56.1	176.7	213.3	70.4	59.2	168.8	207.4
	086	89.2	57.2	214.0	251.0	86.1	60.5	206.5	245.7	82.7	64.2	198.5	240.2	79.3	67.8	190.2	234.4
	096	101.6	64.4	243.6	285.3	98.1	67.9	235.3	279.3	94.4	72.4	226.5	273.6	90.6	76.6	217.4	267.3
	106	112.2	71.3	269.1	315.3	107.8	75.4	258.5	307.4	103.1	79.9	247.2	299.2	98.3	84.4	235.8	290.8
	116	122.6	76.2	294.2	343.5	118.4	80.6	283.9	336.3	113.8	86.0	272.9	328.9	108.9	91.0	261.1	320.5
	126	133.7	83.5	320.7	374.8	129.1	88.6	309.7	367.3	124.2	94.5	297.8	359.3	119.0	100.2	285.3	350.7
	136	148.3	93.8	355.8	416.6	143.3	98.8	343.6	407.8	137.8	104.8	330.6	398.9	132.4	110.7	317.6	389.8
	146	158.0	100.5	378.9	443.9	152.0	106.0	364.5	433.3	145.6	112.1	349.2	422.1	139.6	120.4	334.9	413.3
	161	164.8	103.8	395.2	462.4	162.3	112.5	389.3	462.3	159.3	122.6	382.1	461.9	156.6	134.6	375.7	463.4
	171	173.7	110.3	416.7	488.1	171.3	119.0	410.8	488.1	168.5	129.4	404.2	488.3	166.1	140.5	398.5	490.1
	186	186.0	118.6	446.2	523.0	183.4	128.0	440.0	523.1	180.4	139.0	432.8	523.2	177.8	150.8	426.5	524.8
	206	222.2	136.6	532.9	621.4	219.0	147.7	525.3	621.3	215.4	160.2	516.6	621.0	211.8	174.2	508.1	621.9
	246	261.0	160.3	626.1	729.9	257.5	172.7	617.7	730.0	253.1	188.4	607.0	729.8	248.6	205.0	596.3	730.2
	261	269.3	168.1	646.0	754.9	265.8	180.7	637.6	755.0	261.3	196.5	626.7	754.7	257.2	213.4	616.9	756.2
	271	280.5	176.4	672.8	787.0	276.8	189.9	663.8	787.2	272.1	206.3	652.7	787.0	268.0	224.0	642.8	789.0
48.0	076	83.8	51.3	201.1	234.3	80.6	53.7	193.4	228.2	77.2	56.6	185.2	222.0	73.6	59.8	176.7	215.7
	086	93.0	58.0	223.1	260.5	89.8	60.8	215.4	254.8	86.4	64.7	207.4	249.4	82.8	68.4	198.8	243.4
	096	105.8	65.2	254.0	296.1	102.3	68.3	245.5	289.8	98.5	72.8	236.4	283.8	94.7	77.2	227.2	277.5
	106	117.0	72.3	280.9	327.6	112.6	76.0	270.3	319.6	107.9	80.6	258.9	311.3	103.0	85.2	247.1	302.6
	116	127.8	76.9	306.8	356.5	123.5	81.1	296.3	348.9	118.9	86.4	285.3	341.5	113.9	91.7	273.4	333.2
	126	139.3	84.3	334.4	388.9	134.6	89.3	323.1	381.0	129.7	95.1	311.3	373.1	124.4	100.9	298.6	364.3
	136	154.6	95.0	371.1	432.5	149.5	99.3	358.7	423.2	144.0	105.6	345.5	414.2	138.3	111.7	331.9	404.7
	146	164.8	101.8	395.5	461.3	158.8	106.8	381.1	450.4	152.4	113.1	365.7	439.1	145.7	119.4	349.7	427.5
	161	170.5	104.0	409.2	476.4	168.2	112.1	403.7	476.4	165.3	122.3	396.8	476.3	162.2	133.2	389.1	475.9
	171	179.7	110.6	431.2	502.7	177.4	119.1	425.7	502.9	174.6	129.0	419.0	502.8	171.8	140.1	412.2	503.5
	186	192.3	118.9	461.6	538.4	190.0	127.5	455.9	538.6	186.9	138.6	448.6	538.7	184.0	150.5	441.6	539.7
	206	228.7	136.5	548.8	637.1	226.8	147.7	544.3	640.2	223.3	159.6	535.9	639.7	219.4	173.8	526.5	639.8
	246	270.0	160.3	648.0	751.6	266.6	172.7	639.9	752.0	262.4	187.7	629.8	752.0	257.8	204.5	618.7	752.1
	261	278.5	168.4	668.4	777.3	275.2	180.7	660.4	777.6	270.9	196.1	650.0	777.6	266.4	213.1	639.2	778.2
	271	289.9	176.7	695.8	810.0	286.5	189.3	687.6	810.4	282.0	205.8	676.8	810.6	277.5	223.6	665.9	811.6

LEGEND

- Cap. — Capacity, Tons of Refrigeration
- Cond — Condenser
- kW — Compressor Motor Input Power at Rated Voltage
- LCWT — Leaving Chilled-Water Temperature (F)



30HXC COOLING CAPACITIES (cont)
50 Hz, ENGLISH (cont)

LCWT (F)	UNIT SIZE 30HXC	CONDENSER ENTERING WATER TEMPERATURE (F)															
		80.0				85.0				90.0				95.0			
		Cap.	Input kW	Cooler Flow Rate (Gpm)	Cond Flow Rate (Gpm)	Cap.	Input kW	Cooler Flow Rate (Gpm)	Cond Flow Rate (Gpm)	Cap.	Input kW	Cooler Flow Rate (Gpm)	Cond Flow Rate (Gpm)	Cap.	Input kW	Cooler Flow Rate (Gpm)	Cond Flow Rate (Gpm)
50.0	076	87.2	51.9	209.3	242.8	84.1	54.5	202.0	237.3	80.7	57.1	193.8	230.9	77.1	60.3	185.0	224.3
	086	96.7	58.6	232.2	270.0	93.5	61.6	224.6	264.4	90.1	65.1	216.4	258.6	86.5	69.0	207.7	252.6
	096	110.1	65.8	264.4	306.8	106.5	69.3	255.8	300.6	102.7	73.1	246.7	294.1	98.8	77.8	237.2	287.9
	106	121.9	73.0	292.8	339.9	117.6	76.9	282.3	332.0	112.8	81.2	270.9	323.6	107.8	86.0	258.8	314.8
	116	132.8	77.4	318.9	368.9	128.7	82.0	309.0	362.1	124.1	86.7	297.9	354.3	119.1	92.4	286.0	346.2
	126	144.6	84.9	347.2	402.0	140.3	89.9	336.9	395.1	135.3	95.4	325.0	387.0	130.0	101.7	312.2	378.4
	136	161.1	95.9	386.7	448.6	155.8	100.7	374.0	439.2	150.2	106.2	360.8	429.7	144.4	112.6	346.8	420.1
	146	171.7	102.9	412.3	478.6	165.8	108.0	398.0	467.9	159.3	113.9	382.5	456.5	152.4	120.5	366.0	444.5
	161	176.3	104.0	423.3	490.3	174.1	112.3	418.0	490.7	171.4	122.0	411.5	490.7	168.2	132.9	403.7	490.3
	171	184.9	110.6	444.0	515.3	183.5	119.1	440.7	517.8	180.9	128.7	434.3	517.9	177.9	140.0	427.1	518.2
	186	198.6	119.0	476.9	553.6	196.4	127.9	471.7	554.4	193.6	138.2	464.9	554.6	190.4	150.2	457.2	554.9
	206	235.3	136.1	564.9	652.8	234.8	147.7	563.7	659.3	231.3	159.8	555.4	659.3	227.4	173.5	546.0	659.1
	246	277.5	159.4	666.4	769.3	275.8	173.2	662.2	774.4	272.0	186.8	653.0	774.5	267.2	203.9	641.5	774.4
	261	286.6	167.9	688.1	796.5	284.5	181.5	683.1	800.6	280.6	195.4	673.8	800.8	275.8	212.6	662.2	800.7
	271	298.9	176.3	717.6	831.3	296.1	190.2	711.0	834.1	292.1	205.0	701.2	834.4	287.1	222.9	689.3	834.5
55.0	076	91.0	52.3	218.8	252.4	88.8	55.5	213.4	249.2	85.3	58.0	205.0	242.6	81.6	61.1	196.1	235.7
	086	102.0	59.3	245.2	283.2	99.4	62.8	239.0	279.4	95.9	65.8	230.5	273.1	92.2	69.8	221.7	267.0
	096	115.9	66.5	278.6	321.2	113.2	70.5	272.2	317.6	109.3	74.1	262.8	310.7	105.2	78.5	252.9	303.9
	106	128.8	73.7	309.5	356.8	125.2	78.3	301.0	351.4	120.5	82.2	289.5	342.7	114.4	87.0	275.0	331.4
	116	140.9	77.8	338.6	388.5	137.9	83.4	331.6	385.3	133.1	87.9	320.0	376.9	128.1	93.2	307.9	368.5
	126	154.7	85.5	371.9	426.7	150.0	91.5	360.5	419.4	144.8	96.4	348.1	410.5	139.4	102.5	335.1	401.7
	136	170.6	97.0	410.1	472.3	167.0	102.7	401.3	467.5	161.3	107.7	387.6	457.3	155.3	113.8	373.3	447.2
	146	184.1	104.0	442.4	509.1	179.7	110.5	431.9	503.1	173.2	115.8	416.3	491.3	164.3	122.1	394.8	474.1
	161	184.4	102.8	443.1	509.1	184.4	112.6	443.2	515.8	182.0	121.5	437.5	516.1	179.0	132.4	430.1	516.1
	171	192.8	110.0	463.5	534.0	194.2	119.6	466.7	543.7	192.1	128.7	461.7	545.0	187.6	139.5	450.8	541.4
	186	206.4	118.0	496.0	571.7	206.3	128.3	495.9	578.5	203.8	137.7	489.9	579.0	200.6	149.6	482.2	579.3
	206	244.4	135.0	587.4	674.0	245.0	147.8	588.8	684.2	242.9	159.7	583.8	687.2	239.1	172.8	574.6	686.9
	246	287.9	157.1	692.1	793.0	289.3	172.9	695.3	806.8	286.2	187.1	688.0	809.1	281.9	202.8	677.5	809.3
	261	297.1	166.1	714.2	820.8	298.8	181.8	718.2	835.3	295.2	195.7	709.6	836.3	290.8	211.7	698.9	836.5
	271	309.7	174.4	744.4	856.3	310.9	190.4	747.3	870.1	307.2	204.9	738.4	871.0	302.6	222.0	727.2	871.5
60.0	076	91.1	52.3	219.2	252.6	88.9	55.5	213.9	249.4	85.4	58.0	205.4	242.8	81.7	61.1	196.5	236.0
	086	102.1	59.3	245.6	283.4	99.5	62.8	239.5	279.7	96.0	65.8	231.0	273.3	92.3	69.8	222.1	267.3
	096	116.0	66.5	279.1	321.5	113.4	70.6	272.7	317.9	108.2	73.8	260.2	307.7	104.1	78.4	250.4	301.1
	106	128.9	73.7	310.1	357.1	125.4	78.3	301.5	351.8	119.7	82.0	287.9	340.7	114.6	87.0	275.6	331.8
	116	141.0	77.8	339.2	388.9	138.1	83.4	332.3	385.7	131.6	87.6	316.7	373.1	126.6	93.1	304.6	364.8
	126	153.5	85.5	369.2	423.8	150.2	91.5	361.2	419.9	145.0	96.5	348.8	410.9	139.6	102.6	335.8	402.1
	136	170.8	97.0	410.9	472.8	167.2	102.8	402.1	468.0	161.5	107.8	388.4	457.8	153.5	113.6	369.4	442.8
	146	184.2	104.0	443.2	509.6	177.9	110.2	428.0	498.6	171.5	115.4	412.4	486.8	164.5	122.1	395.6	474.6
	161	183.3	102.9	440.9	506.6	182.9	112.6	440.1	512.3	180.5	121.3	434.3	512.4	177.4	132.5	426.8	512.5
	171	193.0	110.0	464.2	534.4	193.2	119.7	464.7	541.4	190.8	128.6	459.0	541.8	187.8	139.5	451.7	541.9
	186	206.5	118.0	496.8	572.0	206.5	128.3	496.7	579.0	204.0	137.7	490.8	579.5	200.8	149.6	483.0	579.8
	206	244.5	134.9	588.2	674.3	245.1	147.8	589.7	684.5	243.1	159.7	584.7	687.6	239.2	172.7	575.5	687.3
	246	288.1	157.1	693.1	793.4	289.5	172.9	696.3	807.3	286.5	187.1	689.1	809.7	279.0	203.1	671.1	802.4
	261	297.3	166.1	715.3	821.2	299.0	181.7	719.3	835.8	295.5	195.7	710.8	836.9	291.1	211.7	700.1	837.1
	271	309.9	174.3	745.5	856.8	311.2	190.5	748.6	870.7	307.5	204.9	739.7	871.7	302.9	222.0	728.5	872.1

LEGEND

- Cap.** — Capacity, Tons of Refrigeration
- Cond** — Condenser
- kW** — Compressor Motor Input Power at Rated Voltage
- LCWT** — Leaving Chilled-Water Temperature (F)

Performance data (cont)



30HXC COOLING CAPACITIES (cont) 50 Hz, SI

LCWT (C)	UNIT SIZE 30HXC	CONDENSER ENTERING WATER TEMPERATURE (C)											
		25				30				35			
		Cap.	Input kW	Cooler Flow Rate (L/s)	Cond Flow Rate (L/s)	Cap.	Input kW	Cooler Flow Rate (L/s)	Cond Flow Rate (L/s)	Cap.	Input kW	Cooler Flow Rate (L/s)	Cond Flow Rate (L/s)
4.0	076	248.2	47.0	10.6	12.6	229.6	52.0	9.8	12.0	214.4	57.7	9.2	11.6
	086	277.4	53.6	11.9	14.1	258.6	59.6	11.1	13.5	242.2	66.0	10.4	13.1
	096	315.8	60.2	13.5	16.0	295.2	67.2	12.7	15.4	276.8	74.6	11.9	15.0
	106	347.2	66.7	14.9	17.6	320.9	74.0	13.8	16.8	302.7	83.2	13.0	16.4
	116	380.9	71.5	16.3	19.3	354.4	80.0	15.2	18.5	332.6	89.3	14.3	18.0
	126	415.6	78.5	17.8	21.1	387.2	88.0	16.6	20.2	363.4	98.2	15.6	19.6
	136	460.4	88.0	19.7	23.4	430.2	97.6	18.5	22.5	404.8	108.2	17.4	21.8
	146	488.6	94.3	21.0	24.8	453.8	104.4	19.5	23.8	429.2	116.8	18.4	23.2
	161	516.9	99.1	22.2	26.2	500.4	115.4	21.5	26.2	494.8	135.7	21.2	26.8
	171	545.6	105.1	23.4	27.7	531.2	122.0	22.8	27.8	525.1	142.2	22.5	28.4
	186	584.8	113.6	25.1	29.8	569.1	131.4	24.4	29.8	563.8	153.3	24.2	30.5
	206	697.4	130.3	29.9	35.3	677.5	151.0	29.1	35.3	666.5	176.4	28.6	35.9
	246	820.3	152.7	35.2	41.5	795.6	178.1	34.1	41.5	783.2	208.5	33.6	42.2
	261	847.1	159.8	36.3	42.9	823.2	185.5	35.3	43.0	812.7	216.6	34.9	43.8
271	882.6	168.4	37.9	44.8	858.2	195.3	36.8	44.9	848.5	227.9	36.4	45.8	
5.0	076	258.7	47.4	11.1	13.1	239.3	52.4	10.3	12.4	222.5	58.0	9.6	11.9
	086	288.4	54.0	12.4	14.6	269.2	60.2	11.6	14.0	251.4	66.6	10.8	13.5
	096	328.3	60.5	14.1	16.6	307.4	67.8	13.2	16.0	287.3	75.2	12.3	15.4
	106	361.8	67.2	15.5	18.3	334.8	74.7	14.4	17.4	313.5	83.5	13.5	16.9
	116	396.1	72.0	17.0	20.0	369.6	80.6	15.9	19.2	344.7	89.8	14.8	18.5
	126	432.0	79.0	18.5	21.8	403.4	88.6	17.3	21.0	376.6	98.6	16.2	20.2
	136	479.0	88.4	20.6	24.2	447.9	98.4	19.2	23.3	419.9	108.8	18.0	22.5
	146	509.1	95.0	21.9	25.7	472.3	105.1	20.3	24.6	444.6	117.3	19.1	23.9
	161	534.8	98.7	23.0	27.0	517.8	115.3	22.2	27.0	508.8	135.1	21.8	27.4
	171	563.8	105.3	24.2	28.5	548.2	121.6	23.5	28.5	539.8	141.9	23.2	29.0
	186	604.6	113.2	26.0	30.6	587.8	131.1	25.2	30.6	579.4	152.8	24.9	31.2
	206	720.7	130.4	30.9	36.3	700.2	150.7	30.1	36.3	685.5	175.8	29.4	36.7
	246	847.7	152.6	36.4	42.7	823.0	177.6	35.3	42.6	805.3	207.5	34.6	43.1
	261	875.4	159.8	37.6	44.1	850.5	185.2	36.5	44.1	835.4	215.7	35.9	44.8
271	912.2	167.9	39.2	46.0	886.5	194.8	38.1	46.1	872.0	226.9	37.4	46.8	
6.0	076	269.3	48.2	11.6	13.5	249.5	52.9	10.7	12.9	230.8	58.4	9.9	12.3
	086	299.6	54.5	12.9	15.1	280.2	60.7	12.0	14.5	260.7	67.1	11.2	14.0
	096	341.0	61.2	14.6	17.2	319.8	68.2	13.7	16.5	298.1	75.7	12.8	15.9
	106	376.5	67.8	16.2	18.9	349.2	75.3	15.0	18.1	324.5	85.9	13.9	17.5
	116	411.6	72.6	17.7	20.7	385.1	81.2	16.5	19.9	357.0	90.8	15.3	19.1
	126	448.7	79.5	19.3	22.5	420.2	89.1	18.0	21.7	390.0	99.4	16.8	20.8
	136	497.6	89.4	21.4	25.0	466.2	99.0	20.0	24.1	435.5	109.5	18.7	23.2
	146	529.8	95.9	22.8	26.7	492.5	105.9	21.2	25.5	460.4	117.7	19.8	24.6
	161	552.3	98.8	23.7	27.8	535.7	115.0	23.0	27.7	523.3	134.7	22.5	28.0
	171	582.4	105.3	25.0	29.3	566.6	121.5	24.3	29.3	554.9	141.3	23.8	29.7
	186	624.0	113.3	26.8	31.4	607.0	130.8	26.1	31.4	595.3	152.0	25.6	31.8
	206	744.6	130.3	32.0	37.3	724.2	150.4	31.1	37.3	705.6	175.1	30.3	37.5
	246	874.9	152.9	37.6	43.8	851.0	177.1	36.6	43.8	828.3	207.0	35.6	44.1
	261	903.2	160.3	38.8	45.4	878.8	184.8	37.7	45.3	858.5	214.6	36.9	45.7
271	940.9	168.5	40.4	47.3	915.5	194.2	39.3	47.3	895.9	225.6	38.5	47.8	

LEGEND

- Cap. — Capacity, kW
- Cond — Condenser
- kW — Compressor Motor Input Power at Rated Voltage
- LCWT — Leaving Chilled-Water Temperature (C)



30HXC COOLING CAPACITIES (cont)
50 Hz, SI (cont)

LCWT (C)	UNIT SIZE 30HXC	CONDENSER ENTERING WATER TEMPERATURE (C)											
		25				30				35			
		Cap.	Input kW	Cooler Flow Rate (L/s)	Cond Flow Rate (L/s)	Cap.	Input kW	Cooler Flow Rate (L/s)	Cond Flow Rate (L/s)	Cap.	Input kW	Cooler Flow Rate (L/s)	Cond Flow Rate (L/s)
7.0	076	280.1	48.8	12.0	14.0	260.2	53.4	11.2	13.4	239.7	58.8	10.3	12.7
	086	311.0	55.2	13.4	15.6	291.5	61.0	12.5	15.0	270.6	67.4	11.6	14.4
	096	354.0	62.0	15.2	17.7	332.3	68.6	14.3	17.1	309.1	76.1	13.3	16.4
	106	391.5	68.7	16.8	19.6	364.0	75.9	15.6	18.8	336.0	86.1	14.4	18.0
	116	427.5	73.3	18.4	21.4	400.7	81.6	17.2	20.6	370.8	90.6	15.9	19.7
	126	465.9	80.3	20.0	23.3	437.3	89.6	18.8	22.5	405.5	99.7	17.4	21.5
	136	516.8	90.4	22.2	25.9	485.1	99.7	20.8	24.9	451.7	110.1	19.4	23.9
	146	550.9	96.9	23.7	27.6	513.4	106.7	22.1	26.4	477.0	120.1	20.5	25.4
	161	569.9	99.1	24.5	28.5	554.3	114.8	23.8	28.5	539.3	136.4	23.2	28.8
	171	600.8	105.5	25.8	30.1	585.3	121.3	25.2	30.1	571.0	140.8	24.5	30.3
	186	643.4	113.6	27.7	32.3	627.0	130.5	26.9	32.3	611.5	151.2	26.3	32.5
	206	766.1	130.3	32.9	38.2	748.5	150.0	32.2	38.3	727.6	174.7	31.3	38.5
	246	902.6	153.0	38.8	45.0	879.8	176.5	37.8	45.1	852.6	205.4	36.6	45.1
	261	931.4	160.7	40.0	46.6	908.4	184.4	39.0	46.6	882.7	213.6	37.9	46.7
271	970.1	168.8	41.7	48.6	946.0	193.8	40.7	48.6	920.3	224.3	39.6	48.8	
8.0	076	291.0	49.3	12.5	14.5	271.2	53.7	11.7	13.9	249.8	59.3	10.7	13.2
	086	322.8	55.7	13.9	16.1	303.0	61.3	13.0	15.5	281.3	67.9	12.1	14.9
	096	367.4	62.6	15.8	18.3	345.3	68.9	14.8	17.7	321.5	76.7	13.8	17.0
	106	406.7	69.4	17.5	20.3	379.1	76.4	16.3	19.4	348.9	84.6	15.0	18.5
	116	443.7	73.8	19.1	22.1	416.7	81.8	17.9	21.3	386.3	91.2	16.6	20.4
	126	483.1	80.9	20.8	24.1	454.6	89.9	19.5	23.2	422.1	100.3	18.2	22.3
	136	536.5	91.4	23.1	26.8	504.3	100.1	21.7	25.8	469.7	110.9	20.2	24.8
	146	572.3	97.9	24.6	28.6	534.8	107.4	23.0	27.4	495.0	120.1	21.3	26.2
	161	587.9	99.2	25.3	29.3	572.9	114.4	24.6	29.3	553.8	133.5	23.8	29.3
	171	618.0	105.6	26.6	30.9	604.7	121.0	26.0	31.0	588.0	140.4	25.3	31.1
	186	663.1	113.8	28.5	33.1	647.6	130.1	27.8	33.2	629.4	150.7	27.1	33.3
	206	786.3	130.1	33.8	39.1	773.2	150.0	33.2	39.4	750.0	174.1	32.2	39.4
	246	928.1	152.6	39.9	46.1	909.2	175.6	39.1	46.3	880.7	205.0	37.9	46.3
	261	959.2	160.7	41.2	47.8	938.4	183.7	40.4	47.9	910.9	213.4	39.2	47.9
271	999.8	168.9	43.0	49.9	977.1	193.0	42.0	49.9	949.1	224.0	40.8	50.0	
9.0	076	300.8	49.7	12.9	15.0	282.4	54.2	12.1	14.4	260.2	59.8	11.2	13.7
	086	334.1	56.2	14.4	16.7	314.7	61.6	13.5	16.1	292.6	68.5	12.6	15.4
	096	379.9	63.1	16.3	18.9	358.6	69.1	15.4	18.3	334.3	77.3	14.4	17.6
	106	421.6	70.0	18.1	21.0	394.6	76.9	17.0	20.1	363.7	85.3	15.6	19.1
	116	458.4	74.1	19.7	22.7	432.9	82.1	18.6	22.0	402.5	91.8	17.3	21.1
	126	499.1	81.2	21.5	24.8	472.1	90.4	20.3	24.0	439.5	101.0	18.9	23.1
	136	555.4	92.1	23.9	27.6	524.1	100.5	22.5	26.7	488.5	111.8	21.0	25.6
	146	592.8	98.7	25.5	29.5	556.6	108.0	23.9	28.4	514.8	119.5	22.1	27.1
	161	604.7	99.0	26.0	30.0	591.8	114.0	25.5	30.1	572.3	133.2	24.6	30.1
	171	634.5	105.5	27.3	31.6	624.1	121.0	26.9	31.8	606.1	140.1	26.1	31.8
	186	681.5	113.6	29.3	33.9	668.5	129.5	28.8	34.1	649.4	150.5	27.9	34.1
	206	806.9	129.6	34.7	40.0	798.1	150.1	34.3	40.5	774.3	173.8	33.3	40.5
	246	950.6	151.6	40.9	47.1	938.3	175.4	40.4	47.5	909.9	204.5	39.1	47.6
	261	981.7	160.0	42.2	48.7	968.5	183.3	41.7	49.2	940.0	213.0	40.4	49.2
271	1023.9	168.1	44.1	50.9	1008.4	192.0	43.4	51.2	979.1	223.6	42.1	51.3	

LEGEND

- Cap. — Capacity, kW
- Cond — Condenser
- kW — Compressor Motor Input Power at Rated Voltage
- LCWT — Leaving Chilled-Water Temperature (C)

Performance data (cont)



30HXC COOLING CAPACITIES (cont) 50 Hz, SI (cont)

LCWT (C)	UNIT SIZE 30HXC	CONDENSER ENTERING WATER TEMPERATURE (C)											
		25				30				35			
		Cap.	Input kW	Cooler Flow Rate (L/s)	Cond Flow Rate (L/s)	Cap.	Input kW	Cooler Flow Rate (L/s)	Cond Flow Rate (L/s)	Cap.	Input kW	Cooler Flow Rate (L/s)	Cond Flow Rate (L/s)
10.0	076	310.3	50.0	13.4	15.4	293.6	55.0	12.6	14.9	271.0	60.3	11.7	14.1
	086	344.9	56.5	14.8	17.1	326.6	62.1	14.1	16.6	304.2	69.0	13.1	15.9
	096	391.7	63.4	16.9	19.4	372.1	70.0	16.0	18.9	347.5	77.8	15.0	18.1
	106	435.4	70.3	18.7	21.6	410.3	77.6	17.7	20.8	379.0	86.0	16.3	19.8
	116	472.8	74.2	20.4	23.4	449.4	82.8	19.3	22.7	418.9	92.4	18.0	21.8
	126	515.3	81.4	22.2	25.5	489.9	90.9	21.1	24.8	457.2	101.7	19.7	23.9
	136	572.4	92.5	24.6	28.4	544.0	101.6	23.4	27.6	507.9	112.6	21.9	26.5
	146	613.0	99.3	26.4	30.4	578.5	109.1	24.9	29.4	536.1	120.5	23.1	28.0
	161	618.9	98.3	26.6	30.6	610.7	114.0	26.3	30.9	591.4	133.0	25.5	30.9
	171	650.8	105.2	28.0	32.3	643.7	121.0	27.7	32.6	625.6	140.0	26.9	32.7
	186	697.0	113.0	30.0	34.6	689.2	129.6	29.7	35.0	669.6	150.2	28.8	35.0
	206	826.8	128.8	35.6	40.8	823.3	150.0	35.4	41.6	799.7	173.5	34.4	41.5
	246	972.0	150.3	41.8	47.9	967.4	175.8	41.6	48.8	939.6	203.9	40.4	48.8
	261	1003.4	158.8	43.2	49.6	998.0	184.1	43.0	50.5	969.9	212.6	41.7	50.5
271	1046.2	166.9	45.0	51.8	1038.9	192.8	44.7	52.6	1009.6	223.0	43.5	52.6	
13.0	076	326.3	50.2	14.1	16.1	312.5	56.2	13.5	15.7	289.5	61.2	12.5	15.0
	086	362.7	57.0	15.6	17.9	346.7	63.4	14.9	17.5	320.4	69.7	13.8	16.7
	096	411.1	63.8	17.7	20.3	394.1	71.2	17.0	19.9	368.7	78.5	15.9	19.1
	106	458.4	70.5	19.7	22.6	437.4	79.1	18.8	22.1	400.4	86.9	17.3	20.8
	116	499.4	74.4	21.5	24.5	479.8	84.3	20.7	24.1	445.0	93.1	19.2	23.0
	126	548.8	81.7	23.6	26.9	523.5	92.5	22.6	26.3	490.1	102.6	21.1	25.3
	136	604.8	93.1	26.1	29.8	580.8	103.6	25.0	29.2	543.8	113.7	23.4	28.1
	146	652.6	99.6	28.1	32.1	619.9	111.2	26.7	31.2	577.2	122.1	24.9	29.9
	161	645.1	96.6	27.8	31.7	645.3	114.4	27.8	32.5	627.7	132.4	27.0	32.5
	171	678.9	103.8	29.3	33.4	681.4	121.6	29.4	34.3	664.2	139.5	28.6	34.3
	186	721.9	111.6	31.1	35.6	722.7	130.3	31.1	36.4	704.3	149.7	30.3	36.5
	206	863.2	127.9	37.2	42.3	866.1	150.3	37.3	43.4	840.7	172.7	36.2	43.3
	246	1006.3	148.0	43.4	49.3	1012.9	176.0	43.6	50.8	987.1	202.9	42.5	50.8
	261	1033.5	157.0	44.5	50.9	1044.3	184.6	45.0	52.5	1012.3	212.0	43.6	52.3
271	1085.7	164.3	46.8	53.4	1092.2	193.4	47.1	54.9	1065.4	222.0	45.9	55.0	
16.0	076	323.3	50.2	13.9	16.0	308.9	56.0	13.3	15.6	286.0	61.0	12.3	14.8
	086	362.2	57.0	15.6	17.9	346.3	63.4	14.9	17.5	323.5	69.8	14.0	16.8
	096	411.5	63.8	17.7	20.3	394.4	71.2	17.0	19.9	369.0	78.5	15.9	19.1
	106	457.1	70.5	19.7	22.5	435.8	79.1	18.8	22.0	404.4	87.0	17.4	21.0
	116	500.0	74.3	21.6	24.5	480.5	84.3	20.7	24.1	449.3	93.2	19.4	23.2
	126	549.0	81.6	23.7	26.9	522.5	92.5	22.5	26.3	489.0	102.5	21.1	25.3
	136	605.3	93.1	26.1	29.8	581.7	103.7	25.1	29.3	544.7	113.8	23.5	28.1
	146	652.9	99.6	28.2	32.1	625.8	111.5	27.0	31.5	576.0	122.0	24.8	29.8
	161	645.2	96.7	27.8	31.7	645.5	114.4	27.8	32.5	627.9	132.4	27.1	32.5
	171	678.9	103.9	29.3	33.4	680.8	121.5	29.4	34.3	663.6	139.5	28.6	34.3
	186	725.8	111.4	31.3	35.8	728.0	130.3	31.4	36.7	703.9	149.7	30.4	36.5
	206	856.8	128.0	36.9	42.1	859.6	150.3	37.1	43.2	838.5	172.8	36.2	43.2
	246	1008.3	148.1	43.5	49.4	1014.6	175.9	43.8	50.9	988.9	202.8	42.6	50.9
	261	1039.3	156.7	44.8	51.1	1046.2	184.6	45.1	52.6	1020.2	211.8	44.0	52.6
271	1083.0	164.5	46.7	53.3	1088.6	193.4	46.9	54.8	1061.6	222.1	45.8	54.8	
261	1034.8	147.1	44.6	50.9	1041.5	173.3	44.9	51.4	1026.5	198.7	44.2	52.3	
271	1087.7	154.0	46.9	53.5	1094.3	181.4	47.1	54.9	1080.1	208.3	46.5	54.9	

LEGEND

- Cap. — Capacity, kW
- Cond — Condenser
- kW — Compressor Motor Input Power at Rated Voltage
- LCWT — Leaving Chilled-Water Temperature (C)

Performance data (cont)



COMBINATION RATINGS (cont) 60 Hz, ENGLISH (cont)

LCWT (F)	UNIT SIZE 30HXA	09DK AIR-COOLED CONDENSER Unit (Qty)		CONDENSER ENTERING AIR TEMPERATURE (F)														
				85			95			105			115			125		
				Cap.	Input kW	Cooler Flow Rate (Gpm)	Cap.	Input kW	Cooler Flow Rate (Gpm)	Cap.	Input kW	Cooler Flow Rate (Gpm)	Cap.	Input kW	Cooler Flow Rate (Gpm)	Cap.	Input kW	Cooler Flow Rate (Gpm)
45	076	084	(1)	74.3	73.3	178.1	68.9	77.6	165.2	63.3	81.9	151.8	57.3	87.0	137.4	51.6	93.8	123.8
	086	084	(1)	81.1	83.1	194.6	75.3	87.8	180.6	69.0	92.8	165.6	62.4	99.2	149.7	56.4	106.7	135.1
	096	094	(1)	90.8	94.4	217.7	84.2	99.7	202.0	77.3	105.7	185.3	70.2	112.9	168.2	60.5	119.1	145.1
	106	074 (1) and 044	(1)	104.3	104.4	250.0	97.1	110.4	232.8	89.3	116.5	214.2	81.2	124.5	194.8	73.7	133.9	176.8
	116	074 (1) and 054	(1)	111.8	112.9	268.1	104.1	119.5	249.7	95.7	126.3	229.4	87.0	135.4	208.6	79.0	145.5	189.4
	126	074	(2)	123.2	121.2	295.4	115.0	128.4	275.7	105.9	135.8	254.0	96.5	145.3	231.5	87.7	156.4	210.3
	136	074	(2)	133.7	137.4	320.7	124.4	144.9	298.3	114.7	153.5	275.0	104.8	164.2	251.2	90.2	172.7	216.3
	146	084	(2)	148.8	144.8	356.8	139.2	152.9	333.7	128.6	161.2	308.4	117.6	172.2	281.9	107.2	185.6	257.0
	161	084	(2)	152.3	152.1	365.1	146.3	166.1	350.8	139.2	181.4	333.8	131.7	199.3	315.9	114.2	215.6	273.8
	171	084	(2)	163.6	167.6	392.2	157.1	183.1	376.6	148.8	199.9	356.9	141.1	219.2	338.3	125.6	239.7	301.1
	186	084	(2)	177.5	191.0	425.6	169.4	207.5	406.1	160.6	225.8	385.2	152.4	248.7	365.4	124.8	266.6	299.3
	206	084 (2) and 094	(1)	208.4	196.9	499.8	201.4	215.5	482.8	192.9	236.4	462.5	181.7	259.7	435.8	171.6	285.8	411.5
	246	094	(3)	241.7	234.7	579.6	233.8	256.3	560.7	222.1	280.0	532.7	210.2	306.3	504.2	198.6	338.8	476.3
	261	094	(3)	253.5	251.7	607.9	245.0	274.7	587.5	231.8	300.4	555.9	219.9	328.0	527.4	207.7	364.1	498.0
271	094	(3)	266.6	271.6	639.4	257.0	295.1	616.3	242.4	322.5	581.3	230.6	352.8	553.1	217.7	391.8	522.0	
46	076	084	(1)	75.6	74.2	181.4	70.3	78.4	168.6	64.6	82.8	154.9	58.5	87.8	140.2	52.7	94.3	126.4
	086	084	(1)	82.7	84.0	198.3	76.7	88.8	184.0	70.4	93.7	168.7	63.8	99.9	152.9	57.6	107.2	138.1
	096	094	(1)	92.4	95.5	221.7	85.8	100.7	205.9	78.7	106.7	188.9	71.6	113.8	171.7	61.1	119.3	146.5
	106	074 (1) and 044	(1)	106.2	105.5	254.6	99.0	111.5	237.4	91.0	117.8	218.4	82.8	125.6	198.7	75.1	134.9	180.2
	116	074 (1) and 054	(1)	113.8	114.1	272.9	106.1	120.8	254.5	97.5	127.7	233.9	88.8	136.4	213.1	80.6	146.5	193.2
	126	074	(2)	125.5	122.5	301.0	117.1	129.7	280.9	108.2	137.1	259.5	98.6	146.4	236.5	89.5	157.5	214.6
	136	074	(2)	136.2	138.9	326.6	126.8	146.4	304.1	116.9	155.0	280.3	106.8	165.5	256.2	91.0	173.2	218.3
	146	084	(2)	151.6	146.3	363.5	141.8	154.4	340.1	131.2	162.9	314.7	120.0	173.5	287.9	109.3	186.7	262.2
	161	084	(2)	154.7	153.3	371.0	148.7	167.4	356.8	141.6	183.0	339.6	134.0	200.6	321.4	115.1	215.9	276.1
	171	084	(2)	166.1	169.1	398.5	159.7	184.7	383.0	151.5	201.6	363.3	143.4	220.9	344.1	126.6	240.3	303.7
	186	084	(2)	180.4	192.6	432.6	172.3	209.4	413.4	163.2	228.0	391.5	154.9	250.4	371.6	124.9	266.6	299.5
	206	084 (2) and 094	(1)	211.8	198.3	507.9	204.7	217.2	491.1	196.0	238.2	470.2	185.0	261.5	443.8	174.6	287.5	418.7
	246	094	(3)	245.5	236.5	588.9	237.7	258.2	570.3	226.1	282.1	542.4	213.8	308.6	512.9	200.9	340.0	481.8
	261	094	(3)	257.4	253.9	617.4	249.1	276.9	597.4	235.9	303.1	565.8	223.6	330.6	536.4	210.0	365.4	503.8
271	094	(3)	270.9	273.7	649.8	261.6	297.3	627.5	246.5	325.4	591.2	234.6	354.9	562.6	217.7	391.9	522.3	
48	076	084	(1)	78.5	75.9	188.4	73.0	80.0	175.3	67.3	84.4	161.4	61.0	89.1	146.4	54.7	95.7	131.3
	086	084	(1)	85.7	85.8	205.7	79.7	90.6	191.3	73.2	95.6	175.6	66.4	101.4	159.4	59.8	108.7	143.5
	096	094	(1)	95.8	97.6	229.9	89.1	102.9	213.8	81.9	108.6	196.6	74.4	115.7	178.7	62.1	120.0	149.1
	106	074 (1) and 044	(1)	110.1	107.7	264.2	102.7	113.9	246.5	94.7	120.2	227.4	86.3	127.6	207.0	78.1	136.7	187.4
	116	074 (1) and 054	(1)	118.0	116.4	283.1	110.0	123.5	264.0	101.4	130.3	243.4	92.5	138.5	221.9	83.7	148.6	200.9
	126	074	(2)	130.0	125.2	312.0	121.6	132.4	291.9	112.3	140.0	269.6	102.6	148.7	246.2	93.1	159.6	223.4
	136	074	(2)	141.1	142.0	338.6	131.6	149.4	315.9	121.5	157.8	291.7	111.0	168.0	266.4	92.7	174.0	222.5
	146	084	(2)	157.1	149.4	376.9	147.2	157.6	353.2	136.4	166.2	327.4	125.0	176.3	299.9	113.6	189.4	272.7
	161	084	(2)	159.5	155.8	382.9	153.8	170.0	369.1	146.5	185.8	351.5	138.4	203.5	332.2	116.9	216.7	280.6
	171	084	(2)	171.4	172.0	411.3	165.1	187.7	396.1	156.7	205.1	376.0	148.2	224.3	355.7	128.8	241.3	309.1
	186	084	(2)	186.0	196.0	446.5	178.4	213.0	428.1	168.6	232.2	404.6	160.0	254.0	383.9	124.9	266.6	299.8
	206	084 (2) and 094	(1)	218.6	201.1	524.7	211.6	220.5	507.8	202.4	242.0	485.8	191.8	264.9	460.2	178.2	289.9	427.6
	246	094	(3)	253.2	239.9	607.7	245.5	262.1	589.3	234.3	286.6	562.4	221.0	313.3	530.5	205.3	342.2	492.6
	261	094	(3)	265.4	257.8	637.0	257.2	281.5	617.1	244.5	308.0	586.7	231.1	336.0	554.6	214.7	368.1	515.2
271	094	(3)	279.3	278.1	670.3	270.1	302.7	648.1	255.4	331.0	613.0	242.3	360.5	581.6	217.9	391.7	522.9	

LEGEND

- Cap. — Capacity, Tons of Refrigeration
- kW — Compressor Motor Input Power at Rated Voltages
- LCWT — Leaving Chilled-Water Temperature (F)



COMBINATION RATINGS (cont)
60 Hz, ENGLISH (cont)

LCWT (F)	UNIT SIZE 30HXA	09DK AIR-COOLED CONDENSER Unit (Qty)		CONDENSER ENTERING AIR TEMPERATURE (F)														
				85			95			105			115			125		
				Cap.	Input kW	Cooler Flow Rate (Gpm)	Cap.	Input kW	Cooler Flow Rate (Gpm)	Cap.	Input kW	Cooler Flow Rate (Gpm)	Cap.	Input kW	Cooler Flow Rate (Gpm)	Cap.	Input kW	Cooler Flow Rate (Gpm)
50	076	084	(1)	81.3	77.7	195.1	75.8	81.7	181.9	69.9	86.1	167.9	63.6	90.8	152.6	57.1	97.2	137.1
	086	084	(1)	88.8	87.7	213.1	82.6	92.6	198.4	76.1	97.6	182.7	69.1	103.2	165.8	60.9	109.5	146.3
	096	094	(1)	99.3	99.7	238.4	92.4	105.1	221.9	85.0	110.8	204.2	77.3	117.8	185.7	63.4	120.8	152.3
	106	074 (1) and 044	(1)	114.0	110.3	273.8	106.5	116.3	255.7	98.5	122.7	236.4	89.8	129.8	215.7	81.2	138.8	194.9
	116	074 (1) and 054	(1)	122.1	119.3	293.1	114.0	126.2	273.7	105.4	133.1	253.0	96.1	140.8	230.8	87.0	150.6	208.9
	126	074	(2)	134.7	128.0	323.3	126.0	135.2	302.6	116.8	142.8	280.5	106.8	151.0	256.4	96.7	161.9	232.2
	136	074	(2)	146.1	145.2	350.7	136.4	152.6	327.6	126.2	160.7	303.0	115.3	170.8	276.8	94.4	175.1	226.6
	146	084	(2)	162.8	152.8	390.8	152.6	160.8	366.5	141.7	169.6	340.3	130.0	179.1	312.1	118.0	192.0	283.4
	161	084	(2)	164.5	158.3	395.0	158.8	172.7	381.4	151.2	189.0	363.0	143.0	206.6	343.4	117.6	217.4	282.5
	171	084	(2)	176.7	174.9	424.2	170.4	190.9	409.2	161.9	208.8	388.8	153.1	227.6	367.5	129.9	241.9	311.9
	186	084	(2)	191.8	199.6	460.5	184.6	216.7	443.3	173.9	236.5	417.6	165.3	257.3	396.8	123.9	266.7	297.6
	206	084 (2) and 094	(1)	225.5	204.2	541.5	218.2	224.2	523.9	209.1	245.8	502.1	198.6	269.0	476.9	181.8	292.5	436.5
	246	094	(3)	260.9	243.3	626.5	253.2	266.4	607.9	242.7	291.1	582.6	228.4	318.7	548.4	209.8	344.7	503.8
261	094	(3)	273.5	261.7	656.6	265.2	286.3	636.7	253.2	313.0	608.0	238.6	341.9	573.0	219.4	370.7	526.8	
271	094	(3)	287.5	282.7	690.4	278.5	308.4	668.7	264.6	336.6	635.3	250.2	367.2	600.7	217.9	392.0	523.2	
55	076	084	(1)	85.1	79.8	204.6	79.3	83.8	190.7	73.3	88.5	176.1	66.8	93.3	160.6	60.2	99.1	144.6
	086	084	(1)	93.6	90.7	224.9	87.1	95.6	209.5	79.7	100.1	191.6	72.6	105.5	174.6	62.1	110.4	149.4
	096	094	(1)	103.6	102.3	248.9	96.6	107.9	232.1	88.9	113.8	213.8	81.2	120.4	195.1	65.4	121.9	157.1
	106	074 (1) and 044	(1)	120.2	114.0	289.0	111.6	119.6	268.3	103.4	126.2	248.8	93.5	132.1	224.6	83.4	140.3	200.5
	116	074 (1) and 054	(1)	129.5	124.0	311.3	119.9	129.8	288.1	111.0	137.0	266.8	101.5	144.1	243.8	90.0	152.6	216.2
	126	074	(2)	142.9	132.6	343.4	133.8	139.9	321.5	124.2	147.8	298.6	113.0	155.2	271.5	101.3	164.6	243.4
	136	074	(2)	153.5	149.5	368.9	143.6	157.2	345.1	132.9	165.4	319.4	121.6	175.6	292.4	97.5	176.6	234.2
	146	084	(2)	172.6	158.2	414.9	162.0	166.3	389.4	150.8	175.5	362.5	138.7	184.7	333.5	125.1	196.1	300.7
	161	084	(2)	173.2	162.5	416.2	167.4	177.6	402.3	158.1	193.2	380.1	150.1	211.0	360.8	121.4	220.0	291.8
	171	084	(2)	184.9	179.5	444.5	178.7	196.1	429.6	170.4	214.5	409.5	160.6	233.7	386.0	129.0	241.9	310.0
	186	084	(2)	200.5	204.8	482.0	193.6	222.8	465.3	182.9	243.2	439.6	171.8	263.1	413.0	124.1	266.5	298.4
	206	084 (2) and 094	(1)	235.4	208.5	565.7	227.9	229.5	547.7	219.0	251.4	526.4	208.2	275.6	500.4	184.4	294.1	443.1
	246	094	(3)	270.2	247.4	649.5	262.4	271.7	630.7	252.1	297.1	606.0	237.8	325.1	571.5	214.4	348.3	515.4
261	094	(3)	285.8	267.4	687.0	277.5	293.4	666.9	266.6	320.7	640.8	247.8	348.9	595.7	222.0	372.3	533.5	
271	094	(3)	300.4	289.1	722.0	291.5	316.6	700.6	278.6	345.2	669.7	262.3	377.2	630.4	218.1	391.9	524.3	
60	076	084	(1)	85.2	79.9	204.9	79.4	83.9	190.9	73.4	88.5	176.5	66.9	93.3	161.0	59.6	98.8	143.3
	086	084	(1)	93.6	90.8	225.1	86.4	95.1	208.0	79.7	100.2	191.8	72.0	105.1	173.3	62.3	110.3	149.8
	096	094	(1)	103.7	102.4	249.4	96.5	108.1	232.2	89.0	113.8	214.2	81.2	120.5	195.4	65.4	121.9	157.3
	106	074 (1) and 044	(1)	119.6	113.7	287.6	111.7	119.7	268.7	102.3	125.5	246.1	93.5	132.2	225.0	83.5	140.4	200.8
	116	074 (1) and 054	(1)	128.3	123.3	308.7	120.0	129.9	288.6	111.1	137.0	267.2	100.8	143.6	242.4	90.0	152.6	216.5
	126	074	(2)	143.0	132.7	344.1	133.9	139.9	322.2	124.4	147.9	299.1	113.1	155.2	272.0	101.4	164.6	243.8
	136	074	(2)	153.7	149.5	369.7	143.8	157.2	345.9	133.1	165.4	320.1	121.8	175.6	293.0	98.6	177.4	237.1
	146	084	(2)	172.8	158.3	415.7	162.2	166.4	390.1	151.0	175.5	363.6	137.8	184.0	331.4	125.2	196.1	301.2
	161	084	(2)	171.9	161.7	413.5	166.1	176.7	399.6	158.3	193.3	380.8	150.2	211.1	361.4	120.6	219.3	290.0
	171	084	(2)	185.1	179.6	445.2	178.9	196.1	430.4	170.5	214.6	410.2	160.7	233.8	386.6	130.1	241.8	313.0
	186	084	(2)	200.7	205.0	482.8	193.7	223.1	465.9	181.5	242.2	436.7	171.9	263.3	413.6	124.2	266.6	298.7
	206	084 (2) and 094	(1)	235.5	208.6	566.6	228.0	229.5	548.6	219.2	251.5	527.2	208.3	275.7	501.2	184.5	294.1	443.9
	246	094	(3)	270.4	247.6	650.5	262.6	271.9	631.6	252.3	297.2	607.0	238.0	325.2	572.4	214.6	348.5	516.2
261	094	(3)	286.0	267.5	688.0	277.7	293.5	668.0	264.0	319.3	635.1	248.0	349.0	596.5	222.1	372.5	534.3	
271	094	(3)	300.6	289.2	723.1	291.7	316.7	701.7	278.9	345.4	670.8	262.5	377.3	631.5	218.2	392.3	524.9	

LEGEND

- Cap. — Capacity, Tons of Refrigeration
kW — Compressor Motor Input Power at Rated Voltages
LCWT — Leaving Chilled-Water Temperature (F)

Performance data (cont)



COMBINATION RATINGS (cont) 60 Hz, SI

LCWT (C)	UNIT SIZE 30HXA	09DK AIR-COOLED CONDENSER Unit (Qty)		CONDENSER ENTERING AIR TEMPERATURE (C)														
				30			35			40			45			50		
				Cap.	Input kW	Cooler Flow Rate (L/s)	Cap.	Input kW	Cooler Flow Rate (L/s)	Cap.	Input kW	Cooler Flow Rate (L/s)	Cap.	Input kW	Cooler Flow Rate (L/s)	Cap.	Input kW	Cooler Flow Rate (L/s)
4	076	084	(1)	231.7	69.2	9.9	216.1	72.9	9.2	198.6	76.7	8.5	181.2	81.9	7.7	166.4	88.5	7.1
	086	084	(1)	254.3	78.4	10.8	236.2	82.6	10.1	217.3	87.5	9.3	198.8	93.6	8.5	182.0	100.5	7.8
	096	094	(1)	284.3	89.1	12.1	264.7	93.6	11.3	243.5	99.6	10.4	223.3	106.5	9.5	204.7	114.1	8.7
	106	074 (1) and 044	(1)	326.4	98.8	13.9	304.5	103.9	13.0	281.1	109.9	12.0	258.4	117.4	11.0	237.3	126.2	10.1
	116	074 (1) and 054	(1)	350.2	107.1	14.9	326.4	112.7	13.9	301.7	119.4	12.8	277.4	127.9	11.8	254.4	137.0	10.8
	126	074	(2)	386.0	114.9	16.4	360.7	121.2	15.4	333.7	128.2	14.2	307.5	137.1	13.1	282.6	147.2	12.0
	136	074	(2)	418.9	130.0	17.8	391.3	136.5	16.7	362.0	144.8	15.4	334.2	154.9	14.2	307.2	165.9	13.1
	146	084	(2)	466.3	137.5	19.9	436.6	144.4	18.6	405.3	152.1	17.3	373.9	162.7	15.9	345.0	174.5	14.7
	161	084	(2)	485.5	146.3	20.7	465.8	158.5	19.8	444.4	171.7	18.9	424.1	187.5	18.1	402.9	206.8	17.2
	171	084	(2)	521.1	161.4	22.2	498.8	174.5	21.2	476.3	189.0	20.3	454.6	206.6	19.4	432.3	228.5	18.4
	186	084	(2)	564.4	182.9	24.0	536.9	197.1	22.9	514.8	213.2	21.9	490.5	233.9	20.9	465.6	258.3	19.8
	206	084 (2) and 094	(1)	665.3	190.3	28.3	641.2	206.8	27.3	613.6	224.2	26.1	583.6	244.7	24.9	555.1	268.7	23.6
	246	094	(3)	772.8	226.4	32.9	743.9	245.0	31.7	707.4	265.1	30.1	676.2	288.4	28.8	643.0	317.4	27.4
	261	094	(3)	810.1	242.7	34.5	777.0	262.6	33.1	740.5	283.8	31.5	707.8	309.5	30.1	673.0	340.6	28.7
271	094	(3)	851.7	260.9	36.3	812.7	282.1	34.6	777.3	304.2	33.1	742.6	333.0	31.6	705.9	365.4	30.1	
5	076	084	(1)	240.0	70.5	10.2	224.4	74.2	9.6	206.6	78.2	8.8	188.7	83.1	8.0	172.7	89.4	7.4
	086	084	(1)	263.1	79.9	11.2	245.1	84.1	10.4	225.6	89.0	9.6	206.4	94.9	8.8	188.7	101.7	8.0
	096	094	(1)	294.6	90.7	12.6	274.0	95.5	11.7	252.7	101.2	10.8	232.1	107.9	9.9	212.1	115.6	9.0
	106	074 (1) and 044	(1)	337.9	100.6	14.4	315.8	105.8	13.5	292.1	111.5	12.5	268.2	119.0	11.4	246.2	127.7	10.5
	116	074 (1) and 054	(1)	362.3	109.1	15.4	338.4	114.8	14.4	313.1	121.2	13.3	287.7	129.6	12.3	264.2	138.6	11.3
	126	074	(2)	399.2	117.1	17.0	373.8	123.4	15.9	346.8	129.9	14.8	318.8	138.9	13.6	293.0	149.0	12.5
	136	074	(2)	433.6	132.3	18.5	405.4	138.8	17.3	375.4	147.0	16.0	346.6	157.0	14.8	318.5	168.0	13.6
	146	084	(2)	482.3	140.0	20.6	453.2	146.9	19.3	420.8	154.3	17.9	387.9	164.7	16.5	357.9	176.6	15.3
	161	084	(2)	500.7	148.2	21.3	480.3	160.8	20.5	458.9	174.0	19.6	437.5	189.8	18.6	415.5	208.6	17.7
	171	084	(2)	537.5	163.6	22.9	515.1	176.9	22.0	491.5	191.4	20.9	469.0	208.9	20.0	445.7	230.1	19.0
	186	084	(2)	583.3	185.5	24.9	553.9	200.3	23.6	531.2	215.9	22.6	506.4	236.8	21.6	480.2	260.1	20.5
	206	084 (2) and 094	(1)	685.0	193.1	29.2	661.5	209.5	28.2	634.3	227.3	27.0	602.6	247.8	25.7	573.0	270.7	24.4
	246	094	(3)	795.7	229.6	33.9	768.7	248.3	32.8	730.8	268.9	31.1	697.8	291.8	29.7	663.6	320.5	28.3
	261	094	(3)	834.1	246.1	35.5	803.7	266.1	34.3	763.9	288.0	32.6	730.3	312.9	31.1	694.4	344.2	29.6
271	094	(3)	876.6	265.1	37.4	840.2	286.1	35.8	801.4	309.0	34.2	766.4	336.7	32.7	728.4	369.5	31.0	
6	076	084	(1)	248.7	71.8	10.6	232.3	75.7	9.9	214.3	79.7	9.1	196.1	84.3	8.4	179.0	90.4	7.6
	086	084	(1)	272.2	81.5	11.6	253.8	85.8	10.8	234.3	90.4	10.0	214.5	96.1	9.1	196.0	102.7	8.4
	096	094	(1)	304.7	92.6	13.0	283.9	97.4	12.1	262.2	103.0	11.2	240.4	109.5	10.3	219.7	117.0	9.4
	106	074 (1) and 044	(1)	349.7	102.5	14.9	327.3	107.9	14.0	302.8	113.5	12.9	278.2	120.6	11.9	255.4	129.1	10.9
	116	074 (1) and 054	(1)	374.6	111.2	16.0	350.9	116.9	15.0	324.9	122.9	13.9	298.2	131.2	12.7	273.9	140.3	11.7
	126	074	(2)	413.1	119.2	17.6	387.7	125.6	16.5	359.6	132.0	15.3	330.6	140.8	14.1	303.9	150.8	13.0
	136	074	(2)	448.7	134.7	19.1	419.9	141.4	17.9	389.2	149.5	16.6	359.2	159.1	15.3	330.0	170.2	14.1
	146	084	(2)	499.0	142.5	21.3	469.4	149.5	20.0	436.3	156.9	18.6	402.3	167.0	17.2	371.1	178.7	15.8
	161	084	(2)	515.5	150.5	22.0	495.6	163.1	21.1	473.6	176.7	20.2	451.2	192.3	19.2	428.7	210.7	18.3
	171	084	(2)	554.1	165.8	23.6	531.9	179.6	22.7	506.7	194.4	21.6	483.4	211.4	20.6	459.2	232.3	19.6
	186	084	(2)	601.2	188.5	25.6	572.4	203.5	24.4	547.4	219.6	23.3	522.4	239.9	22.3	495.6	262.9	21.1
	206	084 (2) and 094	(1)	705.3	195.7	30.1	682.2	212.3	29.1	655.5	230.4	28.0	621.8	251.0	26.5	591.4	273.4	25.2
	246	094	(3)	818.3	232.9	34.9	792.6	251.9	33.8	755.2	272.8	32.2	719.8	295.8	30.7	684.8	324.0	29.2
	261	094	(3)	858.6	249.6	36.6	830.9	269.6	35.4	788.3	292.3	33.6	753.2	316.6	32.1	716.4	347.9	30.6
271	094	(3)	902.4	269.1	38.5	868.5	290.2	37.0	825.8	313.8	35.2	790.1	340.6	33.7	751.3	374.1	32.0	

LEGEND

- Cap. — Capacity, kW
- kW — Compressor Motor Input Power at Rated Voltages
- LCWT — Leaving Chilled-Water Temperature (C)



COMBINATION RATINGS (cont)
60 Hz, SI (cont)

LCWT (C)	UNIT SIZE 30HXA	09DK AIR-COOLED CONDENSER Unit (Qty)		CONDENSER ENTERING AIR TEMPERATURE (C)														
				30			35			40			45			50		
				Cap.	Input kW	Cooler Flow Rate (L/s)	Cap.	Input kW	Cooler Flow Rate (L/s)	Cap.	Input kW	Cooler Flow Rate (L/s)	Cap.	Input kW	Cooler Flow Rate (L/s)	Cap.	Input kW	Cooler Flow Rate (L/s)
7	076	084	(1)	257.3	73.4	11.0	240.4	77.3	10.3	222.6	81.2	9.5	204.0	85.5	8.7	185.3	91.3	7.9
	086	084	(1)	281.2	83.2	12.0	262.8	87.5	11.2	243.1	91.9	10.4	222.5	97.4	9.5	202.9	103.9	8.7
	096	094	(1)	314.9	94.5	13.4	293.7	99.3	12.5	272.3	104.6	11.6	249.7	110.9	10.7	227.8	118.3	9.7
	106	074 (1) and 044	(1)	361.6	104.5	15.4	338.7	109.9	14.5	314.4	115.4	13.4	288.8	122.4	12.3	264.7	130.6	11.3
	116	074 (1) and 054	(1)	387.5	113.2	16.5	363.4	119.1	15.5	336.6	125.2	14.4	309.3	133.2	13.2	283.7	142.1	12.1
	126	074	(2)	427.4	121.3	18.2	401.3	127.9	17.1	372.7	134.6	15.9	343.2	142.8	14.6	315.1	152.6	13.4
	136	074	(2)	464.0	137.4	19.8	434.3	144.2	18.5	403.5	152.0	17.2	372.3	161.3	15.9	341.9	172.3	14.6
	146	084	(2)	516.2	144.9	22.0	485.8	152.3	20.7	452.5	159.8	19.3	417.7	169.3	17.8	384.5	180.9	16.4
	161	084	(2)	530.3	152.9	22.6	511.1	165.5	21.8	488.9	179.2	20.9	465.0	195.0	19.8	433.5	211.2	18.5
	171	084	(2)	569.9	168.3	24.3	548.7	182.4	23.4	522.9	197.5	22.3	498.1	214.6	21.3	473.4	234.9	20.2
	186	084	(2)	618.9	191.7	26.4	591.2	206.9	25.2	564.0	223.1	24.1	538.3	243.0	23.0	498.3	263.3	21.3
	206	084 (2) and 094	(1)	725.9	198.3	31.0	703.4	214.9	30.0	676.6	233.5	28.9	642.4	254.0	27.4	610.2	276.6	26.0
	246	094	(3)	842.4	236.1	35.9	816.8	255.5	34.9	780.1	276.7	33.3	742.3	299.7	31.7	706.3	327.5	30.1
	261	094	(3)	883.5	253.1	37.7	856.0	273.8	36.5	814.0	296.9	34.7	776.4	321.1	33.1	738.8	351.8	31.5
271	094	(3)	928.9	273.1	39.6	897.4	294.3	38.3	850.9	318.6	36.3	814.4	344.5	34.8	774.3	378.9	33.0	
8	076	084	(1)	266.1	74.9	11.4	249.0	78.7	10.6	231.1	82.6	9.9	211.8	86.7	9.0	192.3	92.4	8.2
	086	084	(1)	290.7	84.8	12.4	272.2	89.1	11.6	251.7	93.6	10.7	230.7	98.9	9.8	210.1	105.3	9.0
	096	094	(1)	325.4	96.4	13.9	304.2	101.2	13.0	281.9	106.3	12.0	258.6	112.7	11.0	236.2	119.9	10.1
	106	074 (1) and 044	(1)	373.6	106.6	16.0	350.5	112.0	15.0	325.7	117.6	13.9	299.8	124.2	12.8	274.2	132.3	11.7
	116	074 (1) and 054	(1)	400.4	115.3	17.1	375.8	121.3	16.0	348.8	127.5	14.9	321.1	135.0	13.7	294.2	143.8	12.6
	126	074	(2)	441.4	123.7	18.8	415.2	130.2	17.7	386.4	137.0	16.5	356.3	144.8	15.2	326.5	154.4	13.9
	136	074	(2)	479.9	140.2	20.5	449.4	147.0	19.2	417.9	154.5	17.8	385.3	163.6	16.5	350.2	173.8	14.9
	146	084	(2)	533.4	147.7	22.8	502.7	155.0	21.5	468.9	162.7	20.0	433.4	171.7	18.5	398.3	183.1	17.0
	161	084	(2)	545.7	155.2	23.3	526.7	167.9	22.5	504.1	181.9	21.5	479.4	197.3	20.5	442.7	212.7	18.9
	171	084	(2)	586.2	171.0	25.0	565.6	185.1	24.1	539.3	200.6	23.0	513.6	217.4	21.9	479.5	235.7	20.5
	186	084	(2)	636.2	194.8	27.2	610.4	210.1	26.1	580.6	226.9	24.8	554.6	246.0	23.7	505.2	264.9	21.6
	206	084 (2) and 094	(1)	747.2	200.8	31.9	724.7	217.9	30.9	696.5	236.9	29.7	663.6	257.1	28.3	629.3	280.3	26.9
	246	094	(3)	866.5	239.4	37.0	841.8	258.9	35.9	805.9	280.4	34.4	765.1	303.8	32.7	728.3	330.9	31.1
	261	094	(3)	908.4	256.8	38.8	881.8	277.8	37.6	840.6	301.3	35.9	800.1	325.9	34.2	761.5	355.8	32.5
271	094	(3)	955.8	277.1	40.8	926.2	298.3	39.5	878.7	323.6	37.5	839.2	349.4	35.8	798.3	383.3	34.1	
9	076	084	(1)	275.1	76.5	11.7	257.6	80.2	11.0	239.9	84.1	10.2	219.8	88.3	9.4	199.6	93.9	8.5
	086	084	(1)	300.5	86.5	12.8	281.4	90.8	12.0	260.8	95.3	11.1	239.2	100.4	10.2	217.9	106.7	9.3
	096	094	(1)	335.9	98.4	14.3	314.5	103.1	13.4	291.8	108.2	12.5	267.8	114.5	11.4	239.6	120.5	10.2
	106	074 (1) and 044	(1)	386.0	108.6	16.5	362.6	114.1	15.5	337.6	119.8	14.4	310.8	126.2	13.3	284.1	134.1	12.1
	116	074 (1) and 054	(1)	431.7	117.4	17.7	388.2	123.8	16.6	361.0	130.0	15.4	332.7	136.9	14.2	304.2	145.7	13.0
	126	074	(2)	456.1	126.1	19.5	429.0	132.7	18.3	400.3	139.5	17.1	369.4	146.8	15.8	338.3	156.4	14.5
	136	074	(2)	494.5	143.1	21.1	464.7	149.8	19.8	432.5	157.1	18.5	399.1	165.9	17.0	355.2	174.5	15.2
	146	084	(2)	551.0	150.4	23.5	519.5	157.9	22.2	485.5	165.7	20.7	449.4	174.1	19.2	412.8	185.5	17.6
	161	084	(2)	561.1	157.4	24.0	542.7	170.2	23.2	519.4	184.5	22.2	494.3	199.8	21.1	447.6	213.5	19.1
	171	084	(2)	602.7	173.7	25.7	582.3	188.0	24.9	556.0	203.6	23.7	528.9	220.3	22.6	489.7	237.6	20.9
	186	084	(2)	654.2	198.0	27.9	629.7	213.4	26.9	597.5	230.8	25.5	571.1	248.8	24.4	503.8	264.6	21.5
	206	084 (2) and 094	(1)	768.8	203.3	32.8	746.5	220.8	31.9	717.4	240.3	30.6	685.2	260.6	29.3	648.6	283.8	27.7
	246	094	(3)	890.8	242.6	38.0	866.2	262.6	37.0	832.1	284.4	35.5	788.5	308.4	33.7	750.2	334.7	32.0
	261	094	(3)	933.8	260.5	39.9	907.2	282.0	38.7	868.2	305.7	37.1	824.0	331.0	35.2	784.1	359.5	33.5
271	094	(3)	982.8	281.0	42.0	952.7	303.3	40.7	907.4	328.6	38.8	863.9	355.2	36.9	821.9	387.3	35.1	

LEGEND

Cap. — Capacity, kW
 kW — Compressor Motor Input Power at Rated Voltages
 LCWT — Leaving Chilled-Water Temperature (C)

Performance data (cont)



COMBINATION RATINGS (cont) 60 Hz, SI (cont)

LCWT (C)	UNIT SIZE 30HXA	09DK AIR-COOLED CONDENSER Unit (Qty)		CONDENSER ENTERING AIR TEMPERATURE (C)														
				30			35			40			45			50		
				Cap.	Input kW	Cooler Flow Rate (L/s)	Cap.	Input kW	Cooler Flow Rate (L/s)	Cap.	Input kW	Cooler Flow Rate (L/s)	Cap.	Input kW	Cooler Flow Rate (L/s)	Cap.	Input kW	Cooler Flow Rate (L/s)
10	076	084	(1)	284.2	78.1	12.1	266.5	81.7	11.4	248.0	85.7	10.6	227.8	90.0	9.7	207.6	95.1	8.9
	086	084	(1)	310.3	88.2	13.3	290.6	92.6	12.4	269.7	97.2	11.5	248.1	101.9	10.6	225.6	108.1	9.6
	096	094	(1)	346.9	100.3	14.8	325.0	105.1	13.9	301.7	110.3	12.9	277.7	116.4	11.9	243.2	121.0	10.4
	106	074 (1) and 044	(1)	398.6	110.7	17.0	374.6	116.3	16.0	349.0	122.2	14.9	322.0	128.2	13.8	294.5	135.9	12.6
	116	074 (1) and 054	(1)	426.7	119.8	18.2	401.1	126.1	17.1	373.7	132.4	16.0	344.7	138.8	14.7	315.0	147.5	13.5
	126	074	(2)	470.7	128.6	20.1	443.3	135.2	18.9	414.1	142.1	17.7	382.6	149.2	16.3	350.5	158.5	15.0
	136	074	(2)	510.4	145.9	21.8	479.9	152.7	20.5	447.3	159.8	19.1	413.0	168.8	17.6	363.9	176.1	15.6
	146	084	(2)	568.7	153.5	24.3	536.8	160.8	22.9	502.6	168.7	21.5	465.4	176.9	19.9	427.5	188.0	18.3
	161	084	(2)	576.7	159.8	24.6	558.7	172.7	23.9	534.3	187.5	22.8	509.3	202.8	21.8	452.6	214.5	19.3
	171	084	(2)	619.3	176.5	26.5	599.3	190.9	25.6	572.6	206.9	24.5	544.3	223.4	23.3	496.1	238.4	21.2
	186	084	(2)	672.1	201.3	28.7	649.3	216.8	27.7	615.1	234.6	26.3	587.5	252.8	25.1	502.1	264.2	21.5
	206	084 (2) and 094	(1)	790.8	206.1	33.8	767.5	224.1	32.8	738.9	243.5	31.6	707.1	264.3	30.2	668.2	287.4	28.6
	246	094	(3)	915.2	245.7	39.1	890.5	266.4	38.1	857.3	288.7	36.6	813.3	313.2	34.8	772.5	339.3	33.0
	261	094	(3)	959.2	264.2	41.0	932.5	286.4	39.8	895.9	310.3	38.3	848.2	336.1	36.2	807.4	363.4	34.5
271	094	(3)	1008.9	285.2	43.1	979.6	308.3	41.9	936.4	333.6	40.0	889.2	361.0	38.0	846.1	391.7	36.2	
13	076	084	(1)	299.4	80.6	12.8	281.1	84.2	12.0	259.5	88.0	11.1	237.1	91.7	10.1	216.0	96.5	9.2
	086	084	(1)	323.6	90.6	13.8	303.6	94.9	13.0	282.4	99.6	12.1	259.8	104.2	11.1	237.0	110.1	10.1
	096	094	(1)	364.2	103.4	15.6	341.7	108.5	14.6	318.0	113.6	13.6	290.2	118.8	12.4	249.7	122.1	10.7
	106	074 (1) and 044	(1)	415.6	113.9	17.8	391.0	119.3	16.7	365.1	125.3	15.6	337.3	131.1	14.4	308.7	138.6	13.2
	116	074 (1) and 054	(1)	448.0	123.8	19.2	421.5	129.9	18.0	393.7	136.3	16.8	363.7	142.5	15.6	332.9	150.8	14.2
	126	074	(2)	498.9	133.3	21.3	470.1	139.8	20.1	440.1	147.0	18.8	404.0	153.1	17.3	370.4	161.8	15.8
	136	074	(2)	540.0	150.9	23.1	508.5	157.9	21.8	474.5	165.3	20.3	439.8	173.9	18.8	373.2	177.4	16.0
	146	084	(2)	607.6	159.7	26.0	569.3	166.2	24.4	534.3	174.4	22.9	496.5	182.7	21.2	452.0	191.9	19.3
	161	084	(2)	602.0	163.2	25.8	583.5	176.8	25.0	559.2	191.6	23.9	534.0	207.4	22.8	461.6	216.1	19.7
	171	084	(2)	652.2	181.8	27.9	632.3	196.8	27.0	606.9	213.3	26.0	575.2	230.6	24.6	503.4	240.1	21.5
	186	084	(2)	702.1	206.4	30.0	679.4	222.8	29.1	646.0	241.0	27.6	614.6	259.8	26.3	501.8	264.1	21.5
	206	084 (2) and 094	(1)	830.4	211.1	35.5	799.3	229.4	34.2	766.7	247.9	32.8	733.9	269.3	31.4	688.8	291.1	29.5
	246	094	(3)	953.4	250.6	40.8	928.3	272.6	39.7	896.6	295.3	38.4	852.3	320.3	36.5	798.6	344.8	34.2
	261	094	(3)	994.1	268.9	42.5	967.6	291.9	41.4	933.4	316.3	39.9	883.4	343.1	37.8	834.6	369.6	35.7
271	094	(3)	1054.9	292.0	45.1	1016.3	315.0	43.5	976.4	340.4	41.8	923.8	368.7	39.5	866.1	395.5	37.0	
16	076	084	(1)	296.7	80.1	12.7	278.3	83.7	11.9	259.3	87.9	11.1	239.2	92.1	10.2	217.9	96.9	9.3
	086	084	(1)	326.1	91.0	14.0	305.8	95.4	13.1	282.0	99.5	12.1	259.5	104.2	11.1	236.8	109.9	10.1
	096	094	(1)	360.9	102.8	15.5	338.7	107.8	14.5	315.0	112.9	13.5	290.4	118.8	12.4	249.6	121.9	10.7
	106	074 (1) and 044	(1)	419.2	114.4	17.9	394.1	119.9	16.9	368.4	125.8	15.8	333.8	130.4	14.3	305.7	137.9	13.1
	116	074 (1) and 054	(1)	451.6	124.4	19.3	420.8	129.6	18.0	392.6	136.1	16.8	362.5	142.3	15.5	331.9	150.6	14.2
	126	074	(2)	498.3	133.1	21.3	469.5	139.6	20.1	439.4	146.8	18.8	407.2	153.9	17.4	373.7	162.4	16.0
	136	074	(2)	535.3	150.1	22.9	503.9	156.9	21.6	470.3	164.3	20.1	435.1	173.1	18.6	376.2	178.0	16.1
	146	084	(2)	602.2	158.7	25.8	568.5	166.1	24.3	533.4	174.3	22.8	495.7	182.5	21.2	456.0	192.5	19.5
	161	084	(2)	605.9	163.9	25.9	587.4	177.6	25.2	558.1	191.2	23.9	532.9	207.2	22.8	465.0	216.8	19.9
	171	084	(2)	647.1	181.0	27.7	627.5	195.8	26.9	601.7	212.3	25.8	570.0	229.7	24.4	503.0	240.1	21.5
	186	084	(2)	701.7	206.4	30.0	679.4	222.5	29.1	646.1	240.7	27.7	609.4	258.7	26.1	501.3	264.1	21.5
	206	084 (2) and 094	(1)	823.5	210.4	35.3	799.7	229.2	34.2	772.2	248.6	33.1	739.4	270.0	31.7	689.3	291.2	29.5
	246	094	(3)	954.7	250.5	40.9	920.9	271.4	39.4	888.8	294.2	38.1	844.4	319.0	36.2	791.6	343.3	33.9
	261	094	(3)	1000.6	269.7	42.8	973.9	293.1	41.7	939.9	317.5	40.2	890.2	344.2	38.1	827.6	367.9	35.4
271	094	(3)	1051.8	291.5	45.0	1023.1	316.2	43.8	983.7	341.6	42.1	930.1	370.1	39.8	867.7	396.1	37.2	

LEGEND

- Cap. — Capacity, kW
- kW — Compressor Motor Input Power at Rated Voltages
- LCWT — Leaving Chilled-Water Temperature (C)



COMBINATION RATINGS (cont)
50 Hz, ENGLISH

LCWT (F)	UNIT SIZE 30HXA	09DK AIR-COOLED CONDENSER Unit (Qty)		CONDENSER ENTERING AIR TEMPERATURE (F)														
				85			95			105			115			125		
				Cap.	Input kW	Cooler Flow Rate (Gpm)	Cap.	Input kW	Cooler Flow Rate (Gpm)	Cap.	Input kW	Cooler Flow Rate (Gpm)	Cap.	Input kW	Cooler Flow Rate (Gpm)	Cap.	Input kW	Cooler Flow Rate (Gpm)
40	076	084	(1)	67.9	68.0	162.4	62.8	72.0	150.5	57.2	76.3	137.0	51.6	82.0	123.6	47.1	89.3	112.7
	086	084	(1)	74.4	78.3	178.2	68.8	82.9	164.6	62.7	88.3	150.1	56.8	95.2	135.9	51.4	103.2	123.1
	096	094	(1)	83.1	88.1	198.9	76.8	93.2	183.7	70.0	99.7	167.6	63.6	107.4	152.3	57.7	115.5	138.1
	106	074 (1) and 044	(1)	94.8	97.2	226.9	87.9	102.9	210.4	80.5	109.4	192.6	73.1	117.8	175.1	66.6	127.4	159.4
	116	074 (1) and 054	(1)	101.8	106.5	243.7	94.3	112.9	225.7	86.4	120.3	206.8	78.6	129.9	188.3	71.3	139.9	170.7
	126	074	(2)	111.9	113.7	267.9	104.0	120.6	249.1	95.5	128.2	228.6	87.1	138.4	208.5	79.1	149.4	189.5
	136	074	(2)	121.0	127.9	289.6	112.4	135.1	269.0	103.3	144.1	247.2	94.6	155.2	226.5	86.4	166.4	206.7
	146	084	(2)	133.9	134.8	320.5	124.9	142.6	299.0	115.2	151.0	275.7	105.4	162.7	252.4	96.3	175.6	230.6
	161	084	(2)	139.4	145.3	333.7	132.9	159.0	318.2	126.1	174.1	301.8	119.0	191.3	284.9	110.5	211.8	264.6
	171	084	(2)	149.3	159.6	357.5	142.1	174.4	340.2	135.0	190.6	323.1	127.4	209.9	305.1	119.8	233.3	286.8
	186	084	(2)	161.3	180.5	386.2	151.8	196.8	363.5	144.8	215.2	346.5	136.0	236.6	325.5	125.9	261.7	301.5
	206	084 (2) and 094	(1)	190.2	188.1	455.4	182.8	206.2	437.5	174.0	226.0	416.5	164.1	248.0	392.9	154.4	274.9	369.7
	246	094	(3)	221.0	224.7	529.1	212.1	245.3	507.8	200.0	268.4	478.8	189.6	294.8	453.8	177.8	326.1	425.5
	261	094	(3)	231.3	240.4	553.6	221.3	262.2	529.7	209.2	286.7	500.8	198.1	315.1	474.3	185.9	348.4	444.9
271	094	(3)	242.4	258.4	580.2	230.5	281.6	551.7	218.7	307.5	523.5	206.4	338.4	494.1	193.0	372.9	462.1	
42	076	084	(1)	70.5	69.4	168.9	65.4	73.6	156.6	59.8	77.9	143.2	54.0	83.3	129.3	48.9	90.5	117.2
	086	084	(1)	77.3	80.0	185.2	71.5	84.7	171.3	65.4	89.9	156.6	59.1	96.6	141.6	53.5	104.5	128.3
	096	094	(1)	86.3	90.2	206.6	79.8	95.3	191.1	72.9	101.6	174.7	66.3	109.1	158.7	59.3	116.8	141.9
	106	074 (1) and 044	(1)	98.4	99.3	235.7	91.5	105.0	219.2	83.9	113.3	201.1	76.3	119.5	182.8	69.3	129.1	166.0
	116	074 (1) and 054	(1)	105.7	108.8	253.1	98.2	115.2	235.2	90.1	122.2	215.8	82.0	131.5	196.3	74.3	141.8	178.0
	126	074	(2)	116.3	115.9	278.6	108.3	123.0	259.4	99.5	130.3	238.4	90.6	140.3	217.1	82.5	151.4	197.5
	136	074	(2)	125.7	130.5	301.1	116.9	137.8	280.1	107.5	146.6	257.6	98.4	157.5	235.8	89.7	169.1	214.8
	146	084	(2)	139.0	137.5	333.1	130.1	145.3	311.6	119.9	153.5	287.3	109.7	164.9	262.9	100.4	177.8	240.5
	161	084	(2)	143.9	147.8	344.7	137.6	161.6	329.6	130.5	176.9	312.7	123.2	194.1	295.1	111.2	212.3	266.4
	171	084	(2)	154.3	162.3	369.7	147.3	177.3	352.9	139.7	193.6	334.6	131.9	212.6	316.1	122.9	234.8	294.4
	186	084	(2)	166.6	184.0	399.0	157.4	200.5	377.2	149.8	218.7	358.8	140.8	240.4	337.4	126.0	261.7	301.9
	206	084 (2) and 094	(1)	196.5	191.0	470.7	189.2	209.1	453.2	180.5	229.2	432.4	170.0	251.7	407.3	160.0	277.3	383.2
	246	094	(3)	228.1	228.2	546.5	219.5	249.1	525.9	207.4	272.5	496.7	196.4	298.6	470.5	184.1	329.9	441.1
	261	094	(3)	238.9	243.9	572.2	229.6	266.1	550.1	216.3	291.0	518.3	205.2	319.2	491.6	192.5	352.5	461.2
271	094	(3)	250.3	262.6	599.7	239.2	286.0	572.9	226.0	312.3	541.3	213.9	343.0	512.4	199.9	377.4	478.9	
44	076	084	(1)	73.3	71.0	175.7	68.0	75.3	162.9	62.3	79.5	149.4	56.4	84.7	135.1	50.9	91.6	122.0
	086	084	(1)	80.2	81.8	192.3	74.3	86.6	178.2	68.0	91.7	163.1	61.7	98.1	147.8	55.7	105.8	133.5
	096	094	(1)	89.5	92.2	214.6	82.9	97.5	198.8	76.0	103.5	182.2	69.0	110.8	165.3	60.3	117.4	144.5
	106	074 (1) and 044	(1)	102.2	101.4	245.0	95.1	107.3	228.0	87.3	113.4	209.4	79.5	121.3	190.5	72.2	130.8	173.0
	116	074 (1) and 054	(1)	109.7	111.0	262.9	102.1	117.6	244.8	93.8	124.2	224.8	85.2	133.5	204.3	77.4	143.7	185.5
	126	074	(2)	120.7	118.4	289.4	112.6	125.5	269.9	103.7	132.7	248.5	94.3	142.4	226.1	85.8	153.4	205.7
	136	074	(2)	130.4	133.5	312.5	121.5	140.9	291.2	112.0	149.3	268.5	102.5	159.9	245.6	90.4	169.0	216.8
	146	084	(2)	144.4	140.3	346.0	135.1	148.3	323.9	124.9	156.5	299.5	114.4	167.3	274.3	104.5	180.2	250.5
	161	084	(2)	148.5	150.4	356.0	142.4	164.2	341.3	135.1	179.7	323.9	127.5	197.1	305.7	114.0	213.6	273.2
	171	084	(2)	159.2	165.1	381.7	152.6	180.2	365.8	144.4	197.0	346.1	136.5	215.5	327.1	125.0	236.1	299.6
	186	084	(2)	171.8	187.6	411.9	163.3	203.9	391.4	154.7	222.5	370.7	145.8	244.3	349.5	126.1	261.8	302.3
	206	084 (2) and 094	(1)	202.9	193.7	486.5	195.7	212.1	469.2	187.0	232.5	448.4	176.1	255.3	422.2	165.7	280.5	397.2
	246	094	(3)	235.4	231.8	564.2	227.0	253.2	544.2	214.9	276.8	515.1	203.2	303.1	487.1	190.7	334.4	457.2
	261	094	(3)	246.5	247.8	590.9	237.6	270.5	569.6	224.0	295.9	536.9	212.4	323.5	509.3	199.3	357.5	477.7
271	094	(3)	258.4	267.0	619.4	248.0	290.5	594.5	233.3	317.2	559.4	221.5	347.8	530.9	207.0	383.2	496.3	

LEGEND

- Cap. — Capacity, Tons of Refrigeration
- kW — Compressor Motor Input Power at Rated Voltages
- LCWT — Leaving Chilled-Water Temperature (F)

Performance data (cont)



COMBINATION RATINGS (cont) 50 Hz, ENGLISH (cont)

LCWT (F)	UNIT SIZE 30HXA	09DK AIR-COOLED CONDENSER Unit (Qty)		CONDENSER ENTERING AIR TEMPERATURE (F)														
				85			95			105			115			125		
				Cap.	Input kW	Cooler Flow Rate (Gpm)	Cap.	Input kW	Cooler Flow Rate (Gpm)	Cap.	Input kW	Cooler Flow Rate (Gpm)	Cap.	Input kW	Cooler Flow Rate (Gpm)	Cap.	Input kW	Cooler Flow Rate (Gpm)
45	076	084	(1)	74.8	71.8	179.3	69.3	76.1	166.2	63.7	80.3	152.8	57.7	85.3	138.3	52.0	92.0	124.6
	086	084	(1)	81.7	82.7	195.9	75.8	87.5	181.9	69.5	92.4	166.7	63.0	98.8	151.1	56.7	106.5	136.1
	096	094	(1)	91.2	93.3	218.6	84.5	98.5	202.7	77.5	104.5	186.0	70.4	111.6	168.9	60.8	117.6	145.8
	106	074 (1) and 044	(1)	104.1	102.5	249.7	97.0	108.4	232.5	89.2	114.5	213.9	81.1	122.3	194.6	73.6	131.6	176.5
	116	074 (1) and 054	(1)	111.8	112.1	268.0	104.1	118.7	249.7	95.6	125.4	229.4	87.0	134.5	208.7	79.0	144.6	189.4
	126	074	(2)	123.0	119.6	294.9	114.8	126.8	275.2	105.7	134.2	253.5	96.3	143.5	231.0	87.5	154.5	209.9
	136	074	(2)	132.8	135.0	318.4	123.8	142.4	296.8	114.2	150.7	274.0	104.4	161.2	250.5	91.1	169.5	218.6
	146	084	(2)	147.1	141.8	352.7	137.7	149.8	330.3	127.5	158.1	305.8	116.8	168.7	280.0	106.6	181.3	255.7
	161	084	(2)	150.8	151.7	361.7	144.8	165.6	347.1	137.4	181.1	329.5	129.7	198.7	311.0	114.9	214.0	275.4
	171	084	(2)	161.7	166.6	387.8	155.2	181.6	372.2	146.9	198.6	352.3	138.8	217.3	332.8	126.0	236.6	302.2
	186	084	(2)	174.5	189.4	418.5	166.2	205.7	398.5	157.1	224.3	376.8	148.3	246.1	355.7	126.2	261.7	302.5
	206	084 (2) and 094	(1)	206.2	195.2	494.4	199.0	213.6	477.3	190.3	234.1	456.4	179.2	257.2	429.7	168.6	282.2	404.2
	246	094	(3)	239.1	233.5	573.3	230.8	255.1	553.5	218.7	278.9	524.5	206.7	305.4	495.6	194.1	336.5	465.5
261	094	(3)	250.4	249.8	600.3	241.6	272.7	579.2	228.0	298.1	546.7	216.1	326.0	518.1	202.8	359.8	486.3	
271	094	(3)	262.5	269.0	629.5	252.5	292.7	605.4	237.0	319.7	568.3	225.4	350.2	540.4	210.7	385.9	505.2	
46	076	084	(1)	76.1	72.7	182.5	70.7	76.8	169.6	65.0	81.1	155.8	58.9	86.0	141.2	53.0	92.5	127.2
	086	084	(1)	83.2	83.7	199.6	77.2	88.4	185.3	70.9	93.2	170.0	64.2	99.6	154.0	58.0	107.0	139.0
	096	094	(1)	92.8	94.3	222.7	86.1	99.6	206.6	79.1	105.4	189.7	71.9	112.4	172.4	61.3	117.9	147.1
	106	074 (1) and 044	(1)	106.0	103.6	254.3	98.8	109.6	237.1	90.9	115.8	218.1	82.7	123.3	198.5	75.0	132.5	180.0
	116	074 (1) and 054	(1)	113.8	113.3	272.9	106.1	120.0	254.5	97.6	126.7	234.0	88.7	135.6	212.9	80.5	145.7	193.0
	126	074	(2)	125.2	120.9	300.4	116.9	128.1	280.4	107.9	135.5	258.8	98.4	144.6	236.1	89.3	155.5	214.1
	136	074	(2)	135.2	136.5	324.2	126.1	143.9	302.5	116.4	152.2	279.2	106.6	162.3	255.7	91.9	170.0	220.5
	146	084	(2)	149.8	143.2	359.4	140.3	151.4	336.6	130.1	159.7	312.1	119.2	170.0	286.0	108.8	182.5	260.9
	161	084	(2)	153.2	152.9	367.5	147.2	166.9	353.0	139.7	182.5	335.2	132.0	200.1	316.5	115.7	214.4	277.6
	171	084	(2)	164.3	168.0	394.0	157.8	183.2	378.5	149.4	200.3	358.4	141.2	219.0	338.6	127.1	237.3	304.8
	186	084	(2)	177.3	190.9	425.3	169.2	207.4	405.8	159.6	226.2	382.8	150.9	247.9	361.9	126.2	261.8	302.7
	206	084 (2) and 094	(1)	209.5	196.4	502.6	202.4	215.3	485.4	193.4	235.8	463.9	182.5	259.0	437.9	171.5	283.9	411.4
	246	094	(3)	242.8	235.2	582.5	234.7	257.0	562.9	222.6	280.9	533.9	210.1	307.7	504.1	197.6	338.6	473.9
261	094	(3)	254.2	251.8	609.8	245.5	275.0	588.8	232.1	300.4	556.6	219.7	328.4	527.1	206.3	362.2	494.9	
271	094	(3)	266.7	271.1	639.6	256.8	295.2	615.9	241.2	322.4	578.5	229.3	352.7	549.9	214.4	388.8	514.2	
48	076	084	(1)	78.9	74.4	189.5	73.5	78.4	176.3	67.7	82.8	162.4	61.4	87.4	147.3	55.0	93.8	132.1
	086	084	(1)	86.3	85.4	207.2	80.3	90.2	192.6	73.7	95.2	177.0	66.9	101.2	160.5	60.2	108.5	144.5
	096	094	(1)	96.2	96.5	230.8	89.4	101.7	214.6	82.2	107.4	197.4	74.7	114.3	179.3	62.5	118.5	150.0
	106	074 (1) and 044	(1)	110.0	105.8	263.9	102.6	111.9	246.2	94.7	118.1	227.2	86.2	125.3	207.0	78.0	134.3	187.2
	116	074 (1) and 054	(1)	118.0	115.6	283.1	110.0	122.7	263.9	101.4	129.5	243.3	92.4	137.8	221.7	83.6	147.8	200.7
	126	074	(2)	129.8	123.6	311.4	121.4	130.8	291.3	112.2	138.3	269.3	102.5	146.8	245.9	92.8	157.7	222.8
	136	074	(2)	140.1	139.6	336.3	131.0	146.9	314.3	121.1	154.9	290.6	110.8	164.7	266.0	93.6	170.9	224.5
	146	084	(2)	155.3	146.5	372.6	145.6	154.5	349.5	135.3	162.9	324.8	124.2	172.6	298.0	113.1	185.0	271.4
	161	084	(2)	158.0	155.3	379.2	152.2	169.4	365.2	144.5	185.2	346.7	136.4	203.1	327.3	116.5	214.7	279.7
	171	084	(2)	169.4	170.9	406.5	163.0	186.2	391.2	154.5	203.5	370.7	146.0	222.3	350.3	128.2	238.0	307.6
	186	084	(2)	182.9	194.2	438.8	175.0	211.1	420.0	164.6	229.9	395.0	156.0	251.4	374.4	126.3	261.8	303.1
	206	084 (2) and 094	(1)	216.3	199.2	519.0	209.0	218.7	501.6	199.7	239.5	479.4	189.3	262.6	454.2	177.5	288.0	425.9
	246	094	(3)	250.4	238.5	600.8	242.2	261.2	581.2	230.7	285.2	553.7	217.0	312.3	520.8	203.1	341.9	487.5
261	094	(3)	262.0	255.8	628.8	253.2	279.7	607.8	240.5	305.3	577.1	226.9	333.7	544.5	212.1	365.5	509.1	
271	094	(3)	274.7	275.5	659.2	264.8	300.7	635.5	249.9	327.8	599.8	236.5	358.6	567.6	218.0	391.2	523.3	

LEGEND

- Cap. — Capacity, Tons of Refrigeration
- kW — Compressor Motor Input Power at Rated Voltages
- LCWT — Leaving Chilled-Water Temperature (F)



COMBINATION RATINGS (cont)
50 Hz, ENGLISH (cont)

LCWT (F)	UNIT SIZE 30HXA	09DK AIR-COOLED CONDENSER Unit (Qty)		CONDENSER ENTERING AIR TEMPERATURE (F)														
				85			95			105			115			125		
				Cap.	Input kW	Cooler Flow Rate (Gpm)	Cap.	Input kW	Cooler Flow Rate (Gpm)	Cap.	Input kW	Cooler Flow Rate (Gpm)	Cap.	Input kW	Cooler Flow Rate (Gpm)	Cap.	Input kW	Cooler Flow Rate (Gpm)
50	076	084	(1)	81.8	76.1	196.3	76.2	80.0	183.0	70.4	84.4	169.0	63.9	89.1	153.5	57.4	95.4	137.9
	086	084	(1)	89.3	87.3	214.5	83.2	92.2	199.7	76.6	97.2	183.9	69.5	103.1	166.9	60.7	109.0	145.9
	096	094	(1)	99.6	98.6	239.2	92.7	103.9	222.6	85.4	109.5	205.0	77.6	116.4	186.4	63.7	119.4	152.9
	106	074 (1) and 044	(1)	113.9	108.3	273.5	106.4	114.3	255.4	98.3	120.6	236.1	89.8	127.5	215.5	81.1	136.4	194.6
	116	074 (1) and 054	(1)	122.1	118.5	293.1	114.1	125.2	273.9	105.4	132.2	253.0	96.1	139.9	230.8	86.9	150.0	208.6
	126	074	(2)	134.4	126.5	322.7	125.8	133.5	302.1	116.6	141.1	279.9	106.6	149.2	256.0	96.5	159.9	231.8
	136	074	(2)	145.2	142.6	348.5	135.8	150.0	326.0	125.8	157.8	302.0	115.1	167.5	276.4	95.3	171.8	228.8
	146	084	(2)	160.9	149.8	386.3	151.1	157.6	362.8	140.6	166.3	337.6	129.2	175.4	310.1	117.6	187.5	282.3
	161	084	(2)	162.9	157.7	391.1	157.1	172.1	377.2	149.2	188.3	358.2	141.0	206.3	338.4	118.4	215.4	284.3
	171	084	(2)	174.6	173.6	419.3	168.3	189.4	404.0	159.6	206.7	383.1	150.7	225.8	361.9	130.4	239.0	313.0
	186	084	(2)	188.4	197.7	452.4	181.0	214.7	434.6	169.7	234.0	407.6	161.1	255.5	386.7	126.4	261.8	303.4
	206	084 (2) and 094	(1)	223.0	202.3	535.4	215.6	222.0	517.6	206.4	243.2	495.5	195.8	266.6	470.1	181.1	290.4	434.9
	246	094	(3)	257.9	241.8	619.2	249.7	265.2	599.6	238.8	289.8	573.3	224.2	317.3	538.4	207.7	344.7	498.7
	261	094	(3)	269.9	259.6	647.9	261.1	284.2	627.0	249.0	310.3	597.9	234.0	339.2	561.8	216.8	368.5	520.5
271	094	(3)	282.7	280.1	678.9	273.0	306.0	655.5	258.8	333.4	621.4	243.8	364.4	585.4	218.1	391.3	523.6	
55	076	084	(1)	85.6	78.2	205.7	79.9	82.1	191.9	73.7	86.8	177.2	67.2	91.5	161.6	60.5	97.2	145.5
	086	084	(1)	94.2	90.2	226.4	87.7	95.1	210.9	80.2	99.8	192.8	73.1	105.4	175.7	62.0	109.7	149.1
	096	094	(1)	103.9	101.1	249.8	96.9	106.8	232.8	89.3	112.4	214.7	81.4	119.1	195.7	65.7	120.4	157.8
	106	074 (1) and 044	(1)	120.0	112.1	288.5	111.5	117.5	268.0	103.3	124.0	248.3	93.4	129.8	224.4	84.2	138.5	202.4
	116	074 (1) and 054	(1)	129.5	123.2	311.3	119.8	129.0	288.0	111.0	136.1	266.8	101.4	143.3	243.8	90.9	152.7	218.5
	126	074	(2)	142.6	131.0	342.8	133.5	138.2	321.0	124.0	146.1	298.1	112.7	153.3	270.9	101.1	162.6	243.0
	136	074	(2)	152.5	146.9	366.6	143.0	154.4	343.6	132.5	162.6	318.5	121.6	172.1	292.3	98.4	173.3	236.5
	146	084	(2)	170.7	155.1	410.3	160.5	163.1	385.7	149.6	172.0	359.7	137.9	180.9	331.4	124.6	191.5	299.5
	161	084	(2)	171.3	162.0	411.8	164.0	176.1	394.1	156.1	192.4	375.2	147.3	224.5	354.0	122.1	218.1	293.5
	171	084	(2)	182.7	178.3	439.0	176.3	194.4	423.7	167.9	212.5	403.5	157.0	255.2	377.3	130.4	239.1	313.5
	186	084	(2)	196.8	203.0	473.1	189.4	220.7	455.2	177.2	239.2	425.9	166.1	286.4	399.3	125.5	261.4	301.6
	206	084 (2) and 094	(1)	232.7	206.5	559.2	225.0	227.3	540.9	216.1	248.5	519.4	204.8	279.9	492.1	183.7	292.1	441.4
	246	094	(3)	267.2	245.8	642.1	258.7	270.5	621.8	248.0	295.6	596.1	233.0	329.5	559.9	211.5	365.7	508.4
	261	094	(3)	282.0	265.2	677.8	273.2	291.1	656.6	261.9	317.7	629.4	242.5	352.8	582.8	219.3	370.2	527.1
271	094	(3)	295.3	286.3	709.7	285.6	314.0	686.6	272.4	341.5	654.8	254.4	391.2	611.4	218.3	391.3	524.7	
60	076	084	(1)	85.7	78.3	206.1	79.8	82.2	192.0	73.8	86.8	177.6	67.3	91.5	161.9	59.9	96.9	144.2
	086	084	(1)	94.2	90.3	226.7	87.0	94.6	209.3	80.2	99.9	192.9	72.5	104.9	174.5	62.1	109.8	149.3
	096	094	(1)	104.0	101.2	250.3	96.9	106.9	233.0	89.4	112.4	215.1	81.6	119.1	196.2	65.7	120.5	158.1
	106	074 (1) and 044	(1)	120.2	112.1	289.1	111.6	117.6	268.4	102.2	123.3	246.0	93.4	129.8	224.8	84.3	138.6	202.7
	116	074 (1) and 054	(1)	128.3	122.4	308.7	119.9	129.1	288.5	111.1	136.2	267.2	101.5	143.3	244.3	90.0	152.0	216.5
	126	074	(2)	142.7	131.1	343.4	133.7	138.2	321.6	124.2	146.2	298.7	112.9	153.4	271.5	101.2	162.6	243.5
	136	074	(2)	152.7	147.0	367.3	143.0	154.6	344.1	132.7	162.6	319.2	121.7	172.1	292.8	99.3	174.3	238.8
	146	084	(2)	170.9	155.2	411.1	160.6	163.2	386.4	149.8	172.1	360.4	136.9	180.2	329.3	124.7	191.6	300.0
	161	084	(2)	170.2	161.2	409.3	164.1	176.1	394.8	156.2	192.5	375.8	147.3	226.2	354.4	122.2	218.1	294.0
	171	084	(2)	182.8	178.4	439.8	176.4	194.5	424.4	168.1	212.5	404.3	157.0	258.0	377.7	130.6	239.0	314.1
	186	084	(2)	196.9	203.3	473.7	188.2	219.8	452.6	177.3	239.3	426.6	166.2	289.1	399.7	125.5	261.5	302.0
	206	084 (2) and 094	(1)	232.9	206.5	560.1	225.2	227.3	541.7	216.2	248.6	520.1	204.9	279.9	492.9	184.9	293.0	444.9
	246	094	(3)	267.3	246.0	643.1	258.8	270.7	622.7	248.2	295.6	597.1	233.1	329.8	560.8	211.6	367.0	509.0
	261	094	(3)	282.3	265.2	679.0	273.4	291.2	657.6	259.6	316.1	624.5	242.6	353.1	583.7	219.5	370.2	527.9
271	094	(3)	295.5	286.3	710.9	285.9	314.1	687.7	272.7	341.6	655.9	252.4	382.0	607.1	218.4	391.5	525.3	

LEGEND

- Cap. — Capacity, Tons of Refrigeration
- kW — Compressor Motor Input Power at Rated Voltages
- LCWT — Leaving Chilled-Water Temperature (F)

Performance data (cont)



COMBINATION RATINGS (cont) 50 Hz, SI

LCWT (C)	UNIT SIZE 30HXA	09DK AIR-COOLED CONDENSER Unit (Qty)		CONDENSER ENTERING AIR TEMPERATURE (C)														
				30			35			40			45			50		
				Cap.	Input kW	Cooler Flow Rate (L/s)	Cap.	Input kW	Cooler Flow Rate (L/s)	Cap.	Input kW	Cooler Flow Rate (L/s)	Cap.	Input kW	Cooler Flow Rate (L/s)	Cap.	Input kW	Cooler Flow Rate (L/s)
4	076	084	(1)	233.3	67.8	9.9	217.4	71.4	9.3	199.8	75.2	8.5	182.1	80.2	7.8	167.5	86.7	7.1
	086	084	(1)	256.1	78.0	10.9	238.1	82.2	10.1	218.8	87.1	9.3	200.2	93.2	8.5	183.4	100.2	7.8
	096	094	(1)	285.3	88.0	12.2	265.5	92.5	11.3	244.3	98.4	10.4	224.3	105.2	9.6	205.6	112.7	8.8
	106	074 (1) and 044	(1)	325.9	97.0	13.9	304.1	102.0	13.0	280.8	107.9	12.0	258.1	115.3	11.0	237.0	123.9	10.1
	116	074 (1) and 054	(1)	350.4	106.2	14.9	326.5	111.9	13.9	301.7	118.6	12.9	277.5	127.1	11.8	254.3	136.1	10.8
	126	074	(2)	385.3	113.4	16.4	360.0	119.6	15.3	333.1	126.5	14.2	306.7	135.5	13.1	282.1	145.3	12.0
	136	074	(2)	416.0	127.7	17.7	388.8	134.1	16.6	360.3	142.2	15.3	333.2	152.1	14.2	307.1	162.4	13.1
	146	084	(2)	460.8	134.6	19.6	432.1	141.5	18.4	401.7	148.9	17.1	371.0	159.3	15.8	342.9	170.7	14.6
	161	084	(2)	481.6	145.8	20.5	460.8	158.0	19.6	439.6	171.5	18.7	417.6	186.6	17.8	394.8	204.7	16.8
	171	084	(2)	515.7	160.1	22.0	492.8	173.4	21.0	470.4	187.9	20.0	447.3	204.6	19.1	423.6	225.0	18.0
	186	084	(2)	555.7	181.1	23.7	526.6	195.6	22.4	504.7	211.9	21.5	477.4	231.0	20.3	449.9	252.6	19.2
	206	084 (2) and 094	(1)	658.2	188.5	28.0	634.0	204.9	27.0	606.5	222.6	25.8	575.5	242.1	24.5	545.6	264.7	23.2
	246	094	(3)	764.7	225.3	32.6	735.0	243.8	31.3	697.4	264.3	29.7	665.3	287.4	28.3	628.6	314.6	26.8
	261	094	(3)	800.1	240.9	34.1	766.7	260.6	32.7	729.4	282.3	31.1	695.2	307.3	29.6	657.3	336.1	28.0
271	094	(3)	838.6	258.7	35.7	799.0	279.6	34.0	762.6	302.8	32.5	725.0	330.0	30.9	683.3	359.5	29.1	
5	076	084	(1)	241.6	69.1	10.3	225.5	72.8	9.6	207.6	76.7	8.8	189.8	81.4	8.1	173.9	87.6	7.4
	086	084	(1)	265.0	79.6	11.3	246.8	83.8	10.5	227.4	88.5	9.7	207.9	94.4	8.9	190.3	101.3	8.1
	096	094	(1)	295.6	89.6	12.6	275.2	94.3	11.7	253.6	100.1	10.8	232.7	106.7	9.9	213.0	114.2	9.1
	106	074 (1) and 044	(1)	337.4	98.8	14.4	315.4	104.0	13.4	291.7	109.6	12.4	267.9	116.9	11.4	246.2	125.3	10.5
	116	074 (1) and 054	(1)	362.4	108.3	15.4	338.4	114.0	14.4	313.1	120.3	13.3	287.8	128.6	12.3	264.3	137.7	11.3
	126	074	(2)	398.6	115.5	17.0	373.4	121.8	15.9	346.0	128.3	14.7	318.2	137.1	13.6	292.5	147.1	12.5
	136	074	(2)	430.8	130.0	18.4	403.3	136.3	17.2	373.7	144.4	15.9	345.7	154.1	14.7	318.4	164.6	13.6
	146	084	(2)	476.7	137.0	20.3	448.3	144.0	19.1	417.0	151.2	17.8	384.8	161.3	16.4	355.6	172.8	15.2
	161	084	(2)	496.4	147.8	21.2	475.6	160.4	20.3	453.8	173.9	19.3	430.8	189.2	18.4	407.4	206.6	17.4
	171	084	(2)	531.8	162.5	22.7	508.7	175.7	21.7	485.6	190.3	20.7	461.6	207.0	19.7	436.8	226.9	18.6
	186	084	(2)	574.1	183.7	24.5	543.9	198.7	23.2	520.9	214.8	22.2	493.0	234.1	21.0	463.7	255.1	19.8
	206	084 (2) and 094	(1)	677.7	191.2	28.9	654.0	207.7	27.9	626.7	225.5	26.7	594.2	245.3	25.3	563.2	267.3	24.0
	246	094	(3)	787.3	228.4	33.6	759.2	247.1	32.4	720.4	268.1	30.7	686.6	291.0	29.3	649.2	318.2	27.7
	261	094	(3)	823.8	244.3	35.1	792.9	264.1	33.8	751.8	286.2	32.0	717.6	310.8	30.6	678.6	340.2	28.9
271	094	(3)	863.3	262.7	36.8	826.2	283.7	35.2	785.5	307.1	33.5	748.5	334.0	31.9	705.6	364.2	30.1	
6	076	084	(1)	250.3	70.3	10.7	233.6	74.2	10.0	215.8	78.1	9.2	197.2	82.7	8.4	180.1	88.6	7.7
	086	084	(1)	274.2	81.1	11.7	255.7	85.4	10.9	236.0	90.0	10.1	216.1	95.7	9.2	196.9	102.6	8.4
	096	094	(1)	305.8	91.4	13.0	284.8	96.2	12.1	263.2	101.8	11.2	241.7	108.1	10.3	220.9	115.5	9.4
	106	074 (1) and 044	(1)	349.2	100.6	14.9	326.9	105.9	13.9	302.7	111.4	12.9	278.1	118.5	11.9	255.0	126.9	10.9
	116	074 (1) and 054	(1)	374.7	110.3	16.0	350.9	116.1	15.0	324.9	122.1	13.9	298.0	130.3	12.7	273.7	139.5	11.7
	126	074	(2)	412.2	117.6	17.6	387.0	124.0	16.5	358.9	130.4	15.3	330.1	139.0	14.1	303.4	148.8	12.9
	136	074	(2)	445.7	132.4	19.0	417.5	139.0	17.8	387.7	146.8	16.5	358.3	156.2	15.3	330.0	166.7	14.1
	146	084	(2)	493.3	139.4	21.0	464.6	146.5	19.8	432.5	153.8	18.4	399.5	163.6	17.0	368.8	174.9	15.7
	161	084	(2)	510.8	150.1	21.8	490.6	162.7	20.9	468.1	176.4	20.0	444.7	191.7	19.0	420.2	209.2	17.9
	171	084	(2)	547.8	164.7	23.4	525.6	178.4	22.4	500.2	193.3	21.3	475.9	209.6	20.3	450.4	229.1	19.2
	186	084	(2)	591.1	186.9	25.2	561.9	201.9	24.0	536.1	218.4	22.9	508.8	237.4	21.7	478.8	258.0	20.4
	206	084 (2) and 094	(1)	697.8	193.9	29.8	674.3	210.4	28.8	647.5	228.5	27.6	613.6	248.4	26.2	581.5	270.0	24.8
	246	094	(3)	809.9	231.7	34.5	782.6	250.8	33.4	744.2	271.8	31.7	708.0	295.0	30.2	670.2	322.0	28.6
	261	094	(3)	848.0	247.7	36.2	819.2	267.7	34.9	775.7	290.4	33.1	740.5	314.6	31.6	700.4	344.2	29.9
271	094	(3)	888.3	266.7	37.9	853.6	287.7	36.4	808.8	311.5	34.5	772.6	338.1	32.9	728.4	369.0	31.1	

LEGEND

- Cap. — Capacity, kW
- kW — Compressor Motor Input Power at Rated Voltages
- LCWT — Leaving Chilled-Water Temperature (C)



COMBINATION RATINGS (cont)
50 Hz, SI (cont)

LCWT (C)	UNIT SIZE 30HXA	09DK AIR-COOLED CONDENSER Unit (Qty)		CONDENSER ENTERING AIR TEMPERATURE (C)														
				30			35			40			45			50		
				Cap.	Input kW	Cooler Flow Rate (L/s)	Cap.	Input kW	Cooler Flow Rate (L/s)	Cap.	Input kW	Cooler Flow Rate (L/s)	Cap.	Input kW	Cooler Flow Rate (L/s)	Cap.	Input kW	Cooler Flow Rate (L/s)
7	076	084	(1)	258.9	71.9	11.0	241.9	75.7	10.3	224.0	79.6	9.6	205.4	83.8	8.8	186.6	89.5	8.0
	086	084	(1)	283.3	82.8	12.1	264.6	87.1	11.3	244.8	91.5	10.4	224.1	97.1	9.6	204.3	103.7	8.7
	096	094	(1)	316.1	93.3	13.5	294.8	98.1	12.6	273.4	103.3	11.7	250.8	109.6	10.7	228.7	116.9	9.8
	106	074 (1) and 044	(1)	361.1	102.6	15.4	338.4	108.0	14.4	314.0	113.4	13.4	288.5	120.3	12.3	264.2	128.4	11.3
	116	074 (1) and 054	(1)	387.5	112.4	16.5	363.3	118.2	15.5	336.6	124.3	14.4	309.1	132.3	13.2	283.5	141.3	12.1
	126	074	(2)	426.5	119.8	18.2	400.5	126.3	17.1	372.0	132.9	15.9	342.8	141.0	14.6	314.5	150.7	13.4
	136	074	(2)	460.7	135.0	19.7	432.1	141.8	18.4	402.0	149.3	17.2	371.5	158.3	15.9	341.9	168.7	14.6
	146	084	(2)	510.3	141.9	21.8	480.8	149.2	20.5	448.7	156.6	19.1	415.0	165.7	17.7	382.5	176.9	16.3
	161	084	(2)	525.4	152.5	22.4	505.9	165.0	21.6	482.7	178.9	20.6	458.7	194.3	19.6	433.5	211.7	18.5
	171	084	(2)	563.5	167.3	24.0	542.0	181.2	23.1	515.9	196.3	22.0	490.9	212.5	20.9	464.2	232.0	19.8
	186	084	(2)	607.7	190.2	25.9	580.5	205.0	24.8	551.8	221.6	23.5	525.1	240.6	22.4	493.9	261.9	21.1
	206	084 (2) and 094	(1)	718.2	196.5	30.6	695.3	213.1	29.7	667.8	231.3	28.5	634.1	251.6	27.1	600.1	273.4	25.6
	246	094	(3)	833.1	234.9	35.6	806.5	254.3	34.4	768.3	275.5	32.8	730.0	298.8	31.2	691.8	325.7	29.5
261	094	(3)	872.4	251.2	37.2	844.0	271.8	36.0	800.9	294.6	34.2	763.3	319.1	32.6	722.6	348.3	30.8	
271	094	(3)	914.2	270.6	39.0	881.7	291.8	37.6	833.0	315.8	35.5	796.9	342.5	34.0	751.4	374.0	32.1	
8	076	084	(1)	267.6	73.5	11.4	250.8	77.1	10.7	232.5	81.0	9.9	213.0	85.0	9.1	193.5	90.6	8.3
	086	084	(1)	292.9	84.4	12.5	273.9	88.7	11.7	253.4	93.1	10.8	232.2	98.6	9.9	211.6	105.0	9.0
	096	094	(1)	326.6	95.3	13.9	305.4	100.0	13.0	283.0	105.1	12.1	259.6	111.3	11.1	237.2	118.5	10.1
	106	074 (1) and 044	(1)	373.0	104.7	15.9	350.2	110.0	15.0	325.4	115.6	13.9	299.5	122.0	12.8	273.7	130.0	11.7
	116	074 (1) and 054	(1)	400.4	114.5	17.1	375.9	120.5	16.0	348.6	126.7	14.9	321.2	134.1	13.7	293.9	143.0	12.5
	126	074	(2)	440.6	122.1	18.8	414.3	128.6	17.7	385.7	135.3	16.5	355.5	143.0	15.2	325.8	152.5	13.9
	136	074	(2)	475.8	137.8	20.3	446.9	144.5	19.1	416.4	151.7	17.8	384.7	160.4	16.4	354.0	170.9	15.1
	146	084	(2)	527.3	144.6	22.5	497.2	152.0	21.2	464.9	159.5	19.8	430.3	168.2	18.4	396.2	179.1	16.9
	161	084	(2)	540.3	154.8	23.1	521.2	167.4	22.3	497.6	181.2	21.2	472.8	196.9	20.2	442.7	213.3	18.9
	171	084	(2)	579.4	170.0	24.7	558.6	183.8	23.8	531.9	199.1	22.7	505.7	215.8	21.6	478.5	234.8	20.4
	186	084	(2)	625.1	193.2	26.7	598.8	208.3	25.6	567.5	224.9	24.2	541.3	243.9	23.1	505.0	264.7	21.6
	206	084 (2) and 094	(1)	739.2	198.9	31.6	716.4	215.9	30.6	687.5	234.4	29.4	655.1	254.9	28.0	619.1	277.1	26.4
	246	094	(3)	856.8	238.0	36.6	830.8	257.8	35.5	793.9	279.1	33.9	751.9	302.9	32.1	713.8	329.5	30.5
261	094	(3)	896.9	254.8	38.3	869.0	275.8	37.1	827.4	298.8	35.3	786.1	323.8	33.6	745.5	352.4	31.8	
271	094	(3)	940.5	274.4	40.2	908.6	296.4	38.8	860.1	320.7	36.7	820.0	347.6	35.0	775.3	378.8	33.1	
9	076	084	(1)	276.7	75.0	11.8	259.2	78.6	11.1	241.1	82.5	10.3	221.2	86.6	9.4	201.1	92.0	8.6
	086	084	(1)	302.6	86.1	12.9	283.3	90.4	12.1	262.6	94.9	11.2	240.9	100.1	10.3	219.4	106.5	9.4
	096	094	(1)	337.5	97.2	14.4	315.5	102.0	13.5	292.9	106.9	12.5	269.0	113.2	11.5	240.6	119.0	10.3
	106	074 (1) and 044	(1)	385.5	106.6	16.5	362.1	112.2	15.5	337.2	117.7	14.4	310.5	123.9	13.3	283.8	131.8	12.1
	116	074 (1) and 054	(1)	413.6	116.5	17.7	388.4	122.9	16.6	360.9	129.1	15.4	332.4	136.1	14.2	304.0	144.9	13.0
	126	074	(2)	455.2	124.5	19.4	428.3	131.1	18.3	399.5	137.8	17.1	368.7	145.0	15.7	337.6	154.5	14.4
	136	074	(2)	491.5	140.6	21.0	462.3	147.2	19.7	431.1	154.2	18.4	398.0	162.9	17.0	358.8	171.6	15.3
	146	084	(2)	544.7	147.5	23.3	514.2	154.8	22.0	481.7	162.4	20.6	446.5	170.6	19.1	410.4	181.4	17.5
	161	084	(2)	555.6	156.9	23.7	536.9	169.6	22.9	512.5	183.7	21.9	487.3	199.7	20.8	447.6	214.1	19.1
	171	084	(2)	595.7	172.6	25.4	575.1	186.6	24.6	548.0	201.9	23.4	521.2	218.7	22.3	488.6	236.7	20.9
	186	084	(2)	642.6	196.3	27.4	617.7	211.5	26.4	583.4	228.2	24.9	557.5	247.2	23.8	503.5	264.3	21.5
	206	084 (2) and 094	(1)	760.5	201.4	32.5	737.3	219.0	31.5	708.1	237.8	30.2	675.9	258.3	28.9	638.1	280.8	27.3
	246	094	(3)	880.7	241.1	37.6	854.4	261.5	36.5	819.9	283.0	35.0	774.6	307.3	33.1	735.3	333.4	31.4
261	094	(3)	921.6	258.5	39.4	893.4	280.1	38.2	854.2	303.1	36.5	808.6	328.5	34.5	767.8	356.3	32.8	
271	094	(3)	966.2	278.5	41.3	934.2	301.2	39.9	888.1	325.5	37.9	843.0	352.7	36.0	798.1	383.2	34.1	

LEGEND

- Cap. — Capacity, kW
- kW — Compressor Motor Input Power at Rated Voltages
- LCWT — Leaving Chilled-Water Temperature (C)

Performance data (cont)



COMBINATION RATINGS (cont) 50 Hz, SI (cont)

LCWT (C)	UNIT SIZE 30HXA	09DK AIR-COOLED CONDENSER Unit (Qty)		CONDENSER ENTERING AIR TEMPERATURE (C)														
				30			35			40			45			50		
				Cap.	Input kW	Cooler Flow Rate (L/s)	Cap.	Input kW	Cooler Flow Rate (L/s)	Cap.	Input kW	Cooler Flow Rate (L/s)	Cap.	Input kW	Cooler Flow Rate (L/s)	Cap.	Input kW	Cooler Flow Rate (L/s)
10	076	084	(1)	285.8	76.5	12.2	268.1	80.1	11.5	249.4	84.1	10.7	229.2	88.2	9.8	208.7	93.4	8.9
	086	084	(1)	312.4	87.8	13.3	292.3	92.2	12.5	271.8	96.7	11.6	249.6	101.8	10.7	227.3	108.0	9.7
	096	094	(1)	348.1	99.1	14.9	326.1	103.9	13.9	302.8	109.0	12.9	278.6	115.0	11.9	244.1	119.6	10.4
	106	074 (1) and 044	(1)	398.1	108.8	17.0	374.1	114.3	16.0	348.6	120.0	14.9	321.7	125.9	13.7	294.0	133.6	12.6
	116	074 (1) and 054	(1)	426.8	119.0	18.2	401.2	125.3	17.1	373.6	131.5	16.0	344.5	138.1	14.7	315.1	146.8	13.5
	126	074	(2)	469.9	127.1	20.1	442.5	133.5	18.9	413.4	140.4	17.7	381.8	147.4	16.3	349.9	156.6	15.0
	136	074	(2)	507.2	143.4	21.7	477.6	150.0	20.4	445.8	157.0	19.1	412.4	165.6	17.6	363.9	172.4	15.6
	146	084	(2)	562.5	150.5	24.0	531.5	157.6	22.7	498.5	165.4	21.3	462.4	173.3	19.8	425.5	183.8	18.2
	161	084	(2)	570.9	159.2	24.4	552.6	172.0	23.6	527.5	186.7	22.5	501.8	202.6	21.4	452.7	215.0	19.3
	171	084	(2)	612.1	175.2	26.2	591.8	189.3	25.3	564.5	205.0	24.1	536.0	222.0	22.9	494.8	237.5	21.1
	186	084	(2)	660.2	199.5	28.2	636.5	214.7	27.2	601.1	232.1	25.7	572.7	251.2	24.5	502.0	263.9	21.5
	206	084 (2) and 094	(1)	781.9	204.2	33.4	758.1	222.1	32.4	729.3	240.9	31.2	697.0	261.8	29.8	657.5	284.3	28.1
	246	094	(3)	904.6	244.2	38.7	878.4	265.2	37.5	843.8	287.4	36.1	798.8	311.6	34.1	756.7	337.9	32.3
	261	094	(3)	946.5	262.1	40.4	918.3	284.2	39.2	881.3	307.5	37.7	831.8	333.2	35.5	790.5	360.6	33.8
271	094	(3)	991.6	282.7	42.4	960.3	305.9	41.0	916.2	330.5	39.2	866.3	357.8	37.0	822.1	388.0	35.1	
13	076	084	(1)	301.0	79.0	12.9	282.8	82.5	12.1	258.8	85.8	11.1	238.6	89.9	10.2	217.2	94.8	9.3
	086	084	(1)	325.8	90.1	13.9	305.6	94.5	13.1	284.2	99.2	12.2	261.4	104.1	11.2	238.4	110.1	10.2
	096	094	(1)	365.6	102.2	15.6	342.9	107.3	14.7	319.1	112.3	13.7	291.3	117.4	12.5	250.7	120.7	10.7
	106	074 (1) and 044	(1)	415.1	111.9	17.8	390.6	117.3	16.7	364.7	123.1	15.6	337.4	128.8	14.4	308.4	136.2	13.2
	116	074 (1) and 054	(1)	448.1	122.9	19.2	421.4	129.0	18.0	393.6	135.4	16.8	363.7	141.8	15.6	332.8	150.1	14.2
	126	074	(2)	501.9	132.3	21.5	469.3	138.1	20.1	439.6	145.2	18.8	403.2	151.3	17.2	369.9	159.8	15.8
	136	074	(2)	536.7	148.3	23.0	506.2	155.2	21.7	473.1	162.5	20.2	439.0	170.7	18.8	377.1	174.4	16.1
	146	084	(2)	601.1	156.5	25.7	563.7	163.0	24.1	530.0	171.0	22.7	493.3	179.1	21.1	450.1	187.5	19.3
	161	084	(2)	595.9	162.6	25.5	576.5	176.2	24.7	552.0	190.8	23.6	523.4	222.3	22.4	461.5	216.8	19.7
	171	084	(2)	644.1	180.5	27.6	623.5	195.1	26.7	598.2	211.2	25.6	560.7	231.8	24.0	502.2	239.1	21.5
	186	084	(2)	689.4	204.5	29.5	665.0	220.6	28.4	631.1	238.2	27.0	593.9	286.1	25.4	501.6	263.8	21.5
	206	084 (2) and 094	(1)	813.4	208.5	34.8	784.4	226.3	33.6	756.6	245.1	32.4	722.8	267.0	30.9	678.2	288.2	29.0
	246	094	(3)	942.1	249.0	40.3	915.2	271.4	39.2	882.0	293.9	37.7	831.4	318.3	35.6	780.6	355.4	33.4
	261	094	(3)	980.7	266.7	42.0	952.7	289.6	40.8	917.2	313.5	39.2	866.0	340.5	37.0	814.5	386.4	34.8
271	094	(3)	1027.0	287.8	43.9	996.0	312.4	42.6	955.0	336.8	40.9	898.5	365.5	38.4	841.9	392.4	36.0	
16	076	084	(1)	298.2	78.5	12.8	279.8	82.0	12.0	260.8	86.2	11.2	240.6	90.3	10.3	219.1	95.1	9.4
	086	084	(1)	328.3	90.6	14.1	307.8	95.0	13.2	283.8	99.1	12.2	261.4	104.0	11.2	238.4	109.9	10.2
	096	094	(1)	362.2	101.6	15.5	339.9	106.6	14.6	316.0	111.7	13.5	291.6	117.4	12.5	250.5	120.5	10.7
	106	074 (1) and 044	(1)	418.6	112.4	17.9	393.6	117.8	16.9	367.9	123.7	15.8	333.4	128.1	14.3	305.4	135.5	13.1
	116	074 (1) and 054	(1)	451.6	123.6	19.3	420.5	128.8	18.0	392.7	135.2	16.8	362.3	141.6	15.5	331.8	150.0	14.2
	126	074	(2)	497.5	131.5	21.3	468.7	137.9	20.1	438.7	145.0	18.8	406.6	152.0	17.4	373.0	160.5	16.0
	136	074	(2)	532.0	147.5	22.8	501.6	154.2	21.5	468.9	161.5	20.1	434.5	169.8	18.6	376.2	174.3	16.1
	146	084	(2)	595.7	155.6	25.5	563.0	162.9	24.1	529.4	170.8	22.7	492.5	178.9	21.1	453.9	188.2	19.4
	161	084	(2)	599.7	163.3	25.7	580.4	176.8	24.9	550.9	190.5	23.6	524.0	213.0	22.4	465.0	217.4	19.9
	171	084	(2)	639.3	179.7	27.4	618.9	194.1	26.5	593.2	210.2	25.4	559.5	238.2	24.0	501.9	239.0	21.5
	186	084	(2)	689.0	204.6	29.5	664.8	220.5	28.5	631.1	238.0	27.0	591.7	267.0	25.3	501.1	263.7	21.5
	206	084 (2) and 094	(1)	814.0	208.4	34.9	789.7	227.0	33.8	761.8	245.9	32.6	728.2	267.2	31.2	683.3	289.5	29.3
	246	094	(3)	943.4	249.0	40.4	907.8	270.3	38.9	874.6	292.6	37.4	828.4	317.9	35.5	778.9	350.0	33.3
	261	094	(3)	987.1	267.6	42.3	958.9	290.7	41.1	923.5	314.6	39.5	862.8	339.7	36.9	813.5	374.1	34.8
271	094	(3)	1033.6	288.8	44.3	1002.6	313.6	42.9	962.2	338.0	41.2	905.2	366.1	38.8	—	—	—	

LEGEND

- Cap. — Capacity, kW
- kW — Compressor Motor Input Power at Rated Voltages
- LCWT — Leaving Chilled-Water Temperature (C)

COOLER PRESSURE DROP

ENGLISH

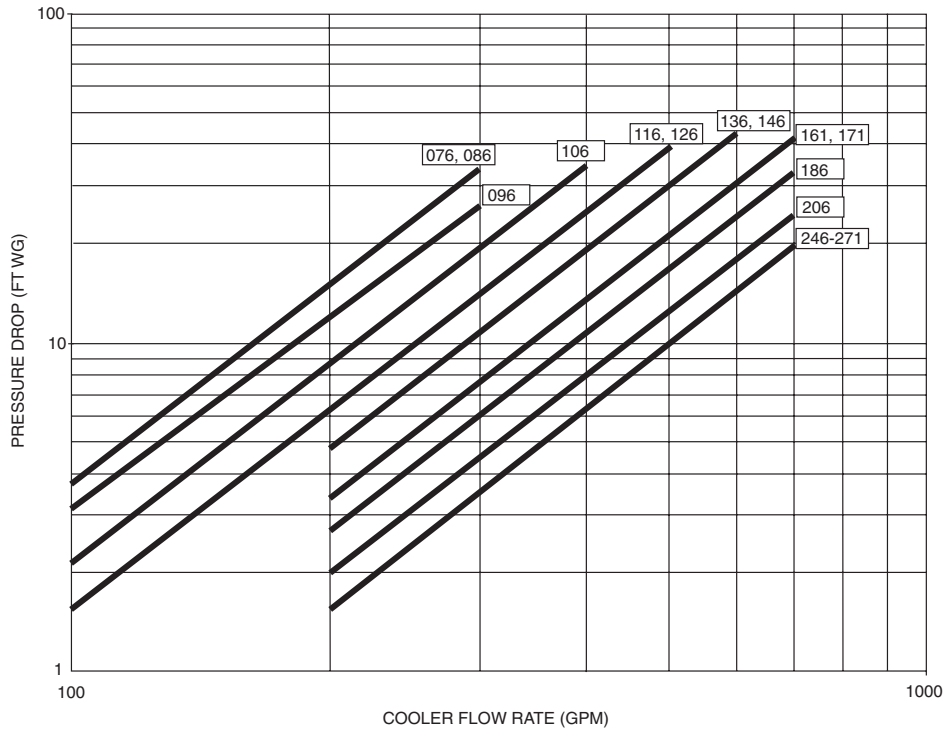

NOTE: Ft of water = 2.31 x change in psig.

SI

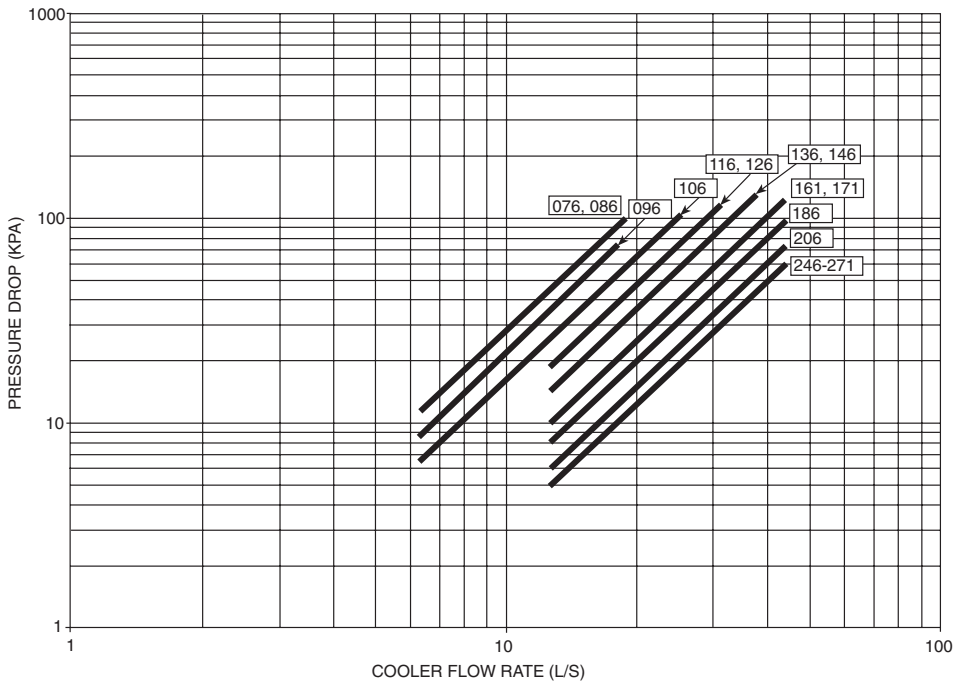

30HXC CONDENSER PRESSURE DROP

ENGLISH

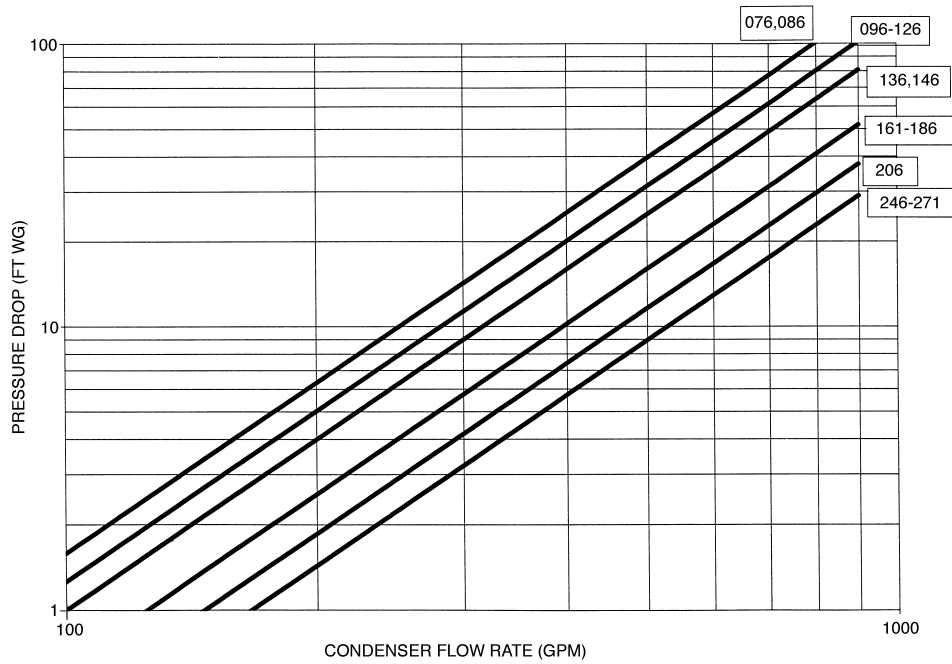

— Unit size range

NOTE: Ft of water = 2.31 x change in psig.

SI

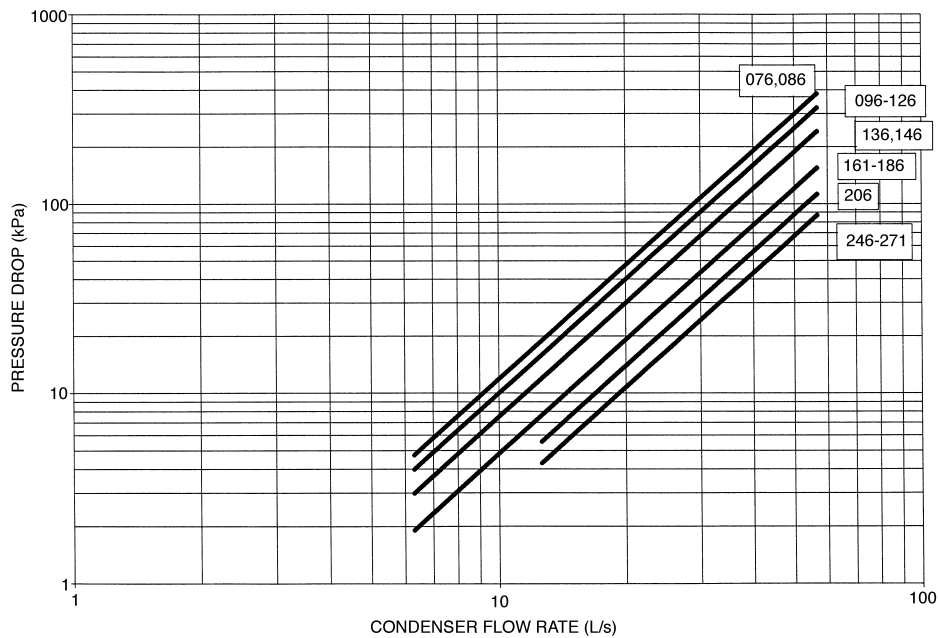

— Unit size range

Typical piping and wiring

Cooler (30HXA, HXC) and condenser (30HXC only)

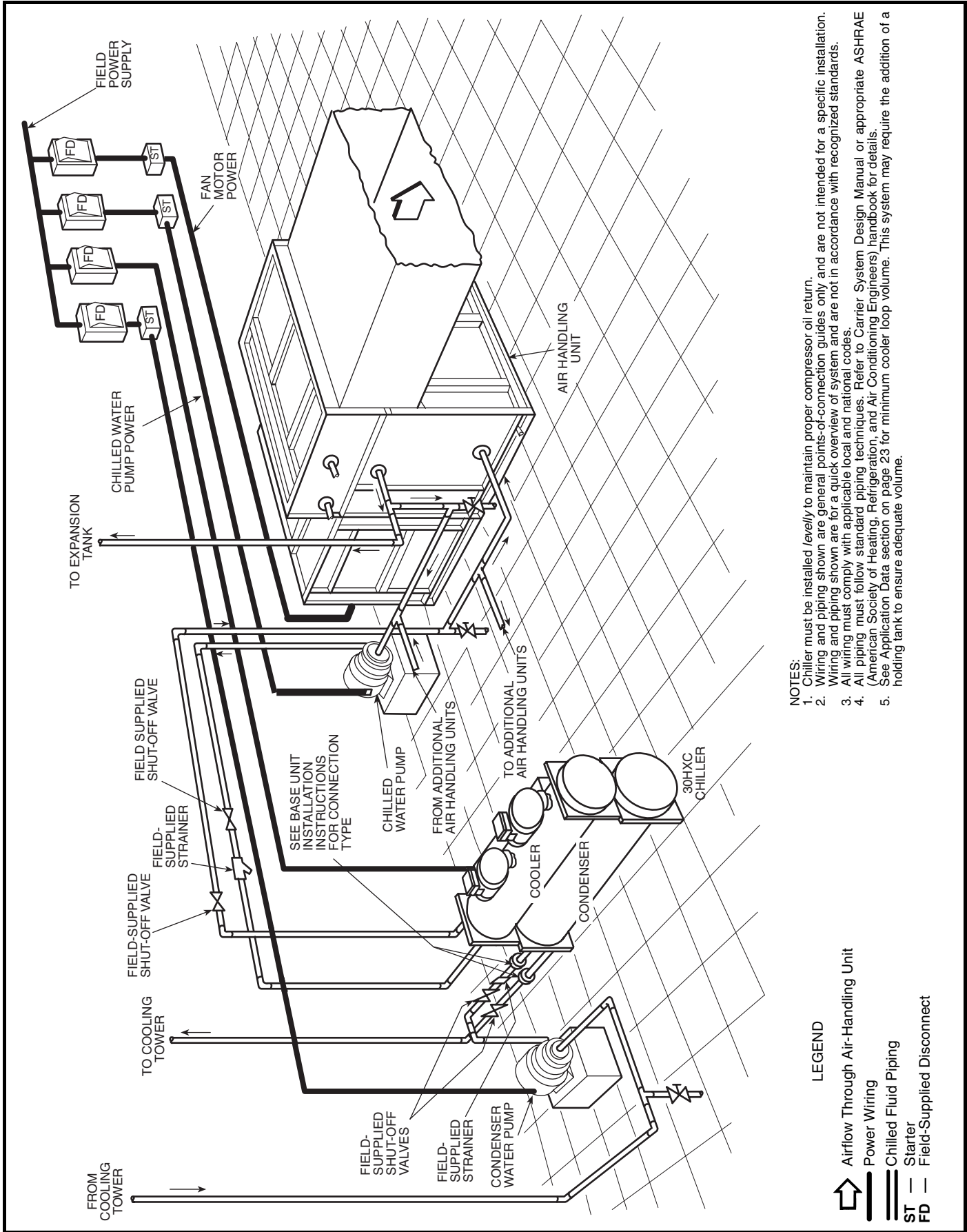

Typical piping and wiring (cont)



POWER AND CONTROL WIRING

NON-FUSED DISCONNECT OPTION

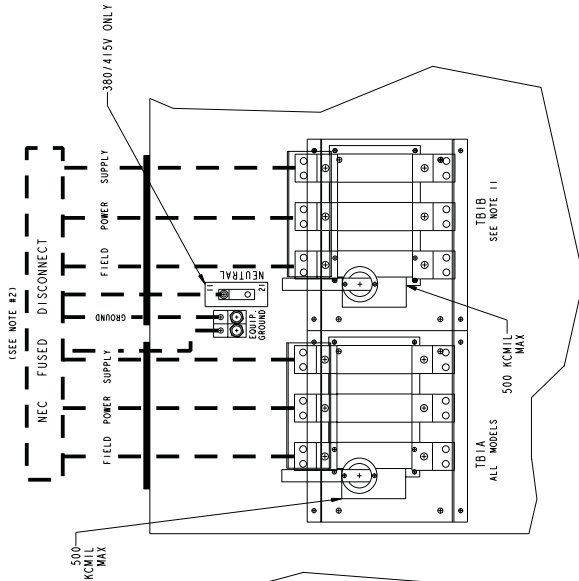

STANDARD POWER

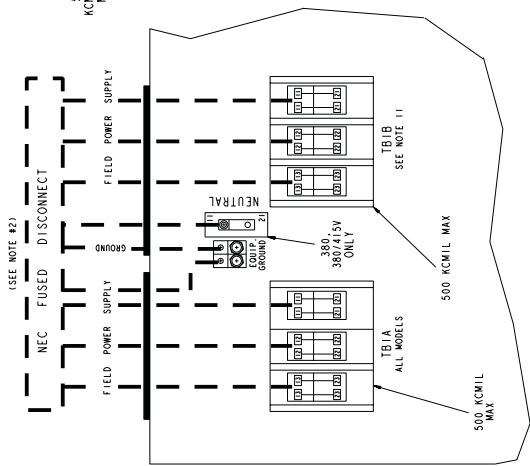

- FACTORY WIRING IS IN ACCORDANCE WITH NATIONAL ELECTRICAL CODE (NEC). FIELD MODIFICATIONS OR ADDITIONS MUST BE IN COMPLIANCE WITH ALL APPLICABLE CODES.
- WIRING FOR MAIN FIELD SUPPLY MUST BE RATED 75°C MINIMUM. USE COPPER FOR ALL UNITS.
- POWER FOR CONTROL CIRCUIT SHOULD BE SUPPLIED FROM A SEPARATE SOURCE (EXCEPT 380/415V UNITS) THROUGH A FIELD SUPPLIED DISCONNECT WITH 15 AMP MAXIMUM PROTECTION FOR 115 VOLT CONTROL CIRCUITS AND 15 AMP MAXIMUM PROTECTION FOR 230 VOLT CONTROL CIRCUIT. CONNECT CONTROL CIRCUIT POWER TO TERMINALS 1 AND 2 OF TB4. CONTROL CIRCUIT CONDUCTORS FOR ALL UNITS MUST BE COPPER ONLY. CONTROL CIRCUIT POWER IS FACTORY WIRED FOR 380/415V UNITS.
- TERMINALS 13 AND 14 OF TB5 ARE FOR FIELD EXTERNAL CONNECTION FOR REMOTE ON-OFF. THE CONTACTS MUST BE RATED FOR DRY CIRCUIT APPLICATION CAPABLE OF HANDLING A 24V AC LOAD UP TO 30 MA.
- TERMINALS 1 & 2 OF TB5 ARE FOR CHILLED WATER PUMP INTERLOCK (CWP) FUNCTIONS. IF ADDED, CHILLED WATER PUMP INTERLOCK CONTACTS MUST BE WIRED IN SERIES WITH FLOW SWITCH CONTACTS. THE CONTACTS MUST BE RATED FOR DRY CIRCUIT APPLICATION CAPABLE OF HANDLING A 24V AC TO 30 MA LOAD. CHILLED WATER FLOW SWITCH (CWFS) IS FACTORY INSTALLED.
- TERMINALS 10 & 12 OF TB5 ARE FOR CONTROL OF CHILLED WATER PUMP STARTER. THE MAXIMUM LOAD ALLOWED FOR THE CHILLED WATER PUMP RELAY IS 75 VA SEALED, 360 VA INRUSH AT 115 OR 230 VOLT. FIELD POWER SUPPLY IS NOT REQUIRED.
- TERMINALS 11 & 12 OF TB5 ARE FOR ALARM RELAY. THE MAXIMUM LOAD ALLOWED FOR THE ALARM RELAY IS 75 VA SEALED, 360 VA INRUSH AT 115 OR 230 VOLT. FIELD POWER SUPPLY IS NOT REQUIRED.
- TERMINAL 7 & 9 OF TB2 ARE FOR CONDENSER WATER PUMP (HCW ONLY) OR CIRCUIT A CONDENSER FAN CONTACTOR (HWA ONLY). TERMINALS 8 & 9 OF TB2 ARE FOR CIRCUIT B CONDENSER FAN CONTACTOR (HXB ONLY) OR LIQUID LINE SOLENOID VALVES (FACTORY WIRED 30HX BRINE). THE MAXIMUM LOAD ALLOWED IS 15 VA SEALED, 360 VA INRUSH AT 115 OR 230 VOLT. SEPARATE FIELD SUPPLY IS NOT REQUIRED. LIQUID LINE SOLENOID VALVES (30HX ONLY) MUST BE CONNECTED IN PARALLEL WITH CONDENSER FAN CONTACTORS AS SHOWN.
- TERMINALS 5 & 6 OF TB2 ARE FOR CONDENSER FLOW SWITCH (CWF) AND/OR CONDENSER PUMP INTERLOCK (CWP). THE CONTACTS MUST BE RATED FOR DRY CIRCUIT APPLICATION CAPABLE OF HANDLING A 24V AC LOAD UP TO 30 MA.
- MAKE APPROPRIATE CONNECTIONS TO TB6 AS SHOWN FOR ENERGY MANAGEMENT BOARD OPTIONS. THE CONTACTS FOR DEMAND LIMIT AND ICE DONE OPTIONS MUST BE RATED FOR DRY CIRCUIT APPLICATION CAPABLE OF HANDLING A 24V AC LOAD UP TO 30 MA.
- TB1B SUPPLIED ON 30HXA186 208/230V Y-DELTA, 30HXA206-271, 208/230, 230V Y-DELTA AND BY SPECIAL ORDER.

- A** Alarm
CFR Condenser Fan Relay
CNFI Condenser Flow Switch
CNPI Condenser Pump Interlock
CNPR Condenser Water Pump
CWFS Chilled Water Flow Switch
CWP Chilled Water Pump
- CWPI** Chilled Water Pump Interlock
EMM Energy Management Module
EWT Entering Water Temperature
FLOP Factory-Installed Option
LLSV Liquid Line Solenoid Valve
LWT Leaving Water Temperature
NEC National Electrical Code

LEGEND

- OAT** Outdoor Air Temperature
SPT Space Temperature
TB Terminal Block
FLOP Factory Installed Wiring
FCW Field Control Wiring
FPW Field Power Wiring

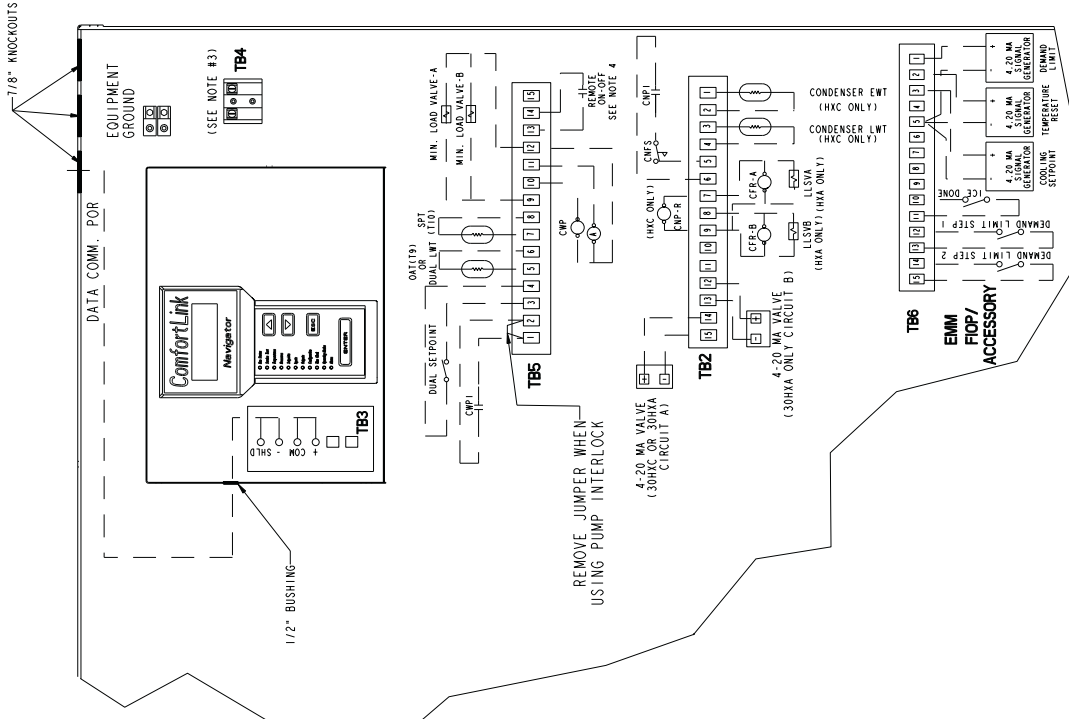

Electrical data



ELECTRICAL DATA, 30HXC UNITS

UNIT 30HXC	UNIT VOLTAGE			POWER SUPPLY QTY. REQD.	NO. POWER SUPPLY CONDUCTORS	UNIT VOLTAGE						CONTROL CIRCUIT			
	V-Hz (3 Ph)	Supplied				MCA	MOCP	ICF		Rec Fuse Size		V-Hz (Single Ph)	Supplied		MCA and MOCP
		Min	Max					XL	WD	XL	WD		Min	Max	
076	230-60	207	253	1	3	198.7	250	—	297.3	—	225	115-60	104	127	15
	208/230-60	187	253	1	3	220.7	300	—	307.1	—	250	115-60	104	127	15
	460-60	414	506	1	3	99.7	125	374.3	148.3	125	125	115-60	104	127	15
	575-60	518	633	1	3	79.7	110	299.4	118.4	90	90	115-60	104	127	15
	380-60	342	418	1	3	120.8	150	418.7	168.7	150	150	230-60	207	254	15
	380/415-50	342	440	1	3	125.6	175	399.8	164.8	150	150	230-50	198	254	15
	230-50	207	253	1	3	207.2	250	—	266.1	—	250	230-50	207	254	15
086	230-60	207	253	1	3	221.7	300	—	297.3	—	250	115-60	104	127	15
	208/230-60	187	253	1	3	246.4	350	—	307.1	—	300	115-60	104	127	15
	460-60	414	506	1	3	111.3	150	374.3	148.3	125	125	115-60	104	127	15
	575-60	518	633	1	3	88.9	125	299.4	118.4	100	100	115-60	104	127	15
	380-60	342	418	1	3	134.8	175	418.7	168.7	175	175	230-60	207	254	15
	380/415-50	342	440	1	3	140.4	200	478.8	189.8	175	175	230-50	198	254	15
	230-50	207	253	1	3	231.9	300	—	305.1	—	300	230-50	207	254	15
096	230-60	207	253	1	3	251.3	350	—	344.3	—	300	115-60	104	127	15
	208/230-60	187	253	1	3	279.2	400	—	354.1	—	350	115-60	104	127	15
	460-60	414	506	1	3	126.2	175	449.3	172.3	150	150	115-60	104	127	15
	575-60	518	633	1	3	100.8	150	359.4	137.4	125	125	115-60	104	127	15
	380-60	342	418	1	3	152.7	225	501.7	194.7	175	175	230-60	207	254	15
	380/415-50	342	440	1	3	157.9	225	561.8	215.8	200	200	230-50	198	254	15
	230-50	207	253	1	3	260.7	350	—	347.1	—	300	230-50	207	254	15
106	230-60	207	253	1	3	285.6	400	—	395.3	—	350	115-60	104	127	15
	208/230-60	187	253	1	3	317.4	450	—	405.1	—	400	115-60	104	127	15
	460-60	414	506	1	3	143.3	200	529.3	197.3	175	175	115-60	104	127	15
	575-60	518	633	1	3	114.5	175	423.4	158.4	150	150	115-60	104	127	15
	380-60	342	418	1	3	173.6	250	589.7	222.7	200	200	230-60	207	254	15
	380/415-50	342	440	1	3	178.1	250	660.8	246.8	225	225	230-50	198	254	15
	230-50	207	253	1	3	294.2	450	—	397.1	—	350	230-50	207	254	15
116	230-60	207	253	1	3	304.1	450	—	413.7	—	350	115-60	104	127	15
	208/230-60	187	253	1	3	337.9	500	—	425.6	—	400	115-60	104	127	15
	460-60	414	506	1	3	152.6	225	538.6	206.6	175	175	115-60	104	127	15
	575-60	518	633	1	3	121.9	175	430.8	165.8	150	150	115-60	104	127	15
	380-60	342	418	1	3	184.8	250	600.9	233.9	225	225	230-60	207	254	15
	380/415-50	342	440	1	3	190.0	250	672.7	258.7	225	225	230-50	198	254	15
	230-50	207	253	1	3	313.9	450	—	416.8	—	400	230-50	207	254	15
126	230-60	207	253	1	3	327.7	450	—	437.4	—	400	115-60	104	127	15
	208/230-60	187	253	1	3	364.2	500	—	451.9	—	450	115-60	104	127	15
	460-60	414	506	1	3	164.5	225	550.5	218.5	200	200	115-60	104	127	15
	575-60	518	633	1	3	131.4	175	440.3	175.3	150	150	115-60	104	127	15
	380-60	342	418	1	3	199.1	250	615.2	248.2	225	225	230-60	207	254	15
	380/415-50	342	440	1	3	204.0	300	686.7	272.7	250	250	230-50	198	254	15
	230-50	207	253	1	3	337.0	450	—	439.9	—	400	230-50	207	254	15
136	230-60	207	253	1	3	366.7	500	—	497.4	—	450	115-60	104	127	15
	208/230-60	187	253	1	6	407.4	600	—	511.9	—	500	115-60	104	127	15
	460-60	414	506	1	3	183.8	250	645.5	248.5	225	225	115-60	104	127	15
	575-60	518	633	1	3	147.1	200	536.3	199.3	175	175	115-60	104	127	15
	380-60	342	418	1	3	222.8	300	720.2	282.2	300	300	230-60	207	254	15
	380/415-50	342	440	1	3	230.2	300	796.7	307.7	300	300	230-50	198	254	15
	230-50	207	253	1	6	380.3	500	—	495.9	—	450	230-50	207	254	15
146	230-60	207	253	1	6	394.1	500	—	524.9	—	450	115-60	104	127	15
	208/230-60	187	253	1	6	437.9	600	—	542.4	—	500	115-60	104	127	15
	460-60	414	506	1	3	197.5	250	659.2	262.2	225	225	115-60	104	127	15
	575-60	518	633	1	3	158.1	225	547.3	210.3	200	200	115-60	104	127	15
	380-60	342	418	1	3	239.5	350	736.9	298.9	300	300	230-60	207	254	15
	380/415-50	342	440	1	3	246.3	350	812.8	323.8	300	300	230-50	198	254	15
	230-50	207	253	1	6	407.1	600	—	522.7	—	500	230-50	207	254	15
161	230-60	207	253	1	6	398.7	600	—	574.8	—	500	115-60	104	127	15
	208/230-60	187	253	1	6	443.0	600	—	590.6	—	600	115-60	104	127	15
	460-60	414	506	1	3	200.1	300	756.2	287.2	250	250	115-60	104	127	15
	575-60	518	633	1	3	159.9	225	604.9	229.9	200	200	115-60	104	127	15
	380-60	342	418	1	3	242.2	350	843.2	325.2	300	300	230-60	207	254	15
	380/415-50	342	440	1	3	249.0	350	944.2	358.2	300	300	230-50	198	254	15
	230-50	207	253	1	6	411.3	600	—	577.7	—	500	230-50	207	254	15

Electrical data (cont)



ELECTRICAL DATA, 30HXC UNITS (cont)

UNIT 30HXC	UNIT VOLTAGE			POWER SUPPLY QTY. REQD.	NO. POWER SUPPLY CONDUCTORS	UNIT VOLTAGE						CONTROL CIRCUIT			
	V-Hz (3 Ph)	Supplied				MCA	MOCP	ICF		Rec Fuse Size		V-Hz (Single Ph)	Supplied		MCA and MOCP
		Min	Max					XL	WD	XL	WD		Min	Max	
171	230-60	207	253	1	6	428.4	600	—	604.5	—	500	115-60	104	127	15
	208/230-60	187	253	1	6	476.0	700	—	623.6	—	600	115-60	104	127	15
	460-60	414	506	1	3	215.0	300	771.1	302.1	250	250	115-60	104	127	15
	575-60	518	633	1	3	171.8	250	616.8	241.8	200	200	115-60	104	127	15
	380-60	342	418	1	3	260.2	350	861.2	343.2	300	300	230-60	207	254	15
	380/415-50	342	440	1	3	266.6	350	961.8	375.8	300	300	230-50	198	254	15
	230-50	207	253	1	6	440.4	600	—	606.8	—	500	230-50	207	254	15
186	230-60	207	253	1	6	462.3	600	—	638.5	—	600	115-60	104	127	15
	208/230-60	187	253	1	6	513.7	700	—	661.3	—	600	115-60	104	127	15
	460-60	414	506	1	3	232.0	300	788.1	319.1	300	300	115-60	104	127	15
	575-60	518	633	1	3	185.4	250	630.4	255.4	225	225	115-60	104	127	15
	380-60	342	418	1	3	280.8	400	881.8	363.8	350	350	230-60	207	254	15
	380/415-50	342	440	1	3	289.4	400	984.6	398.6	350	350	230-50	198	254	15
	230-50	207	253	1	6	478.1	600	—	644.5	—	600	230-50	207	254	15
206	230-60	207	253	1	6	524.5	700	—	700.7	—	600	115-60	104	127	15
	208/230-60	187	253	1	6	582.8	800	—	730.4	—	700	115-60	104	127	15
	460-60	414	506	1	3	263.2	350	819.3	350.3	300	300	115-60	104	127	15
	575-60	518	633	1	3	210.4	250	655.4	280.4	250	250	115-60	104	127	15
	380-60	342	418	1	3	318.6	400	919.6	401.6	350	350	230-60	207	254	15
	380/415-50	342	440	1	3	326.8	450	1022.0	436.0	400	400	230-50	198	254	15
	230-50	207	253	1	6	539.8	700	—	706.2	—	600	230-50	207	254	15
246	230-60	207	253	1	6	604.1	800	—	780.3	—	700	115-60	104	127	15
	208/230-60	187	253	1	6	671.3	800	—	818.9	—	800	115-60	104	127	15
	460-60	414	506	1	3	303.2	400	859.3	390.3	350	350	115-60	104	127	15
	575-60	518	633	1	3	242.3	300	687.3	312.3	300	300	115-60	104	127	15
	380-60	342	418	1	3	367.0	450	968.0	450.0	400	400	230-60	207	254	15
	380/415-50	342	440	1	3	377.6	500	1072.8	486.8	450	450	230-50	198	254	15
	230-50	207	253	1	6	623.8	800	—	790.2	—	700	230-50	207	254	15
261	230-60	207	253	1	6	633.8	800	—	810.0	—	700	115-60	104	127	15
	208/230-60	187	253	1	6	704.3	800	—	851.9	—	800	115-60	104	127	15
	460-60	414	506	1	3	318.1	400	874.2	405.2	350	350	115-60	104	127	15
	575-60	518	633	1	3	254.2	300	699.2	324.2	300	300	115-60	104	127	15
	380-60	342	418	1	6	385.0	500	986.0	468.0	450	450	230-60	207	254	15
	380/415-50	342	440	1	6	395.2	500	1090.4	504.4	450	450	230-50	198	254	15
	230-50	207	253	1	6	652.9	800	—	819.3	—	800	230-50	207	254	15
271	230-60	207	253	1	6	667.8	800	—	843.9	—	800	115-60	104	127	15
	208/230-60	187	253	1	6	742.0	800	—	889.6	—	800	115-60	104	127	15
	460-60	414	506	1	3	335.1	400	891.2	422.2	400	400	115-60	104	127	15
	575-60	518	633	1	3	267.8	350	712.8	337.8	300	300	115-60	104	127	15
	380-60	342	418	1	6	405.6	500	1006.6	488.6	450	450	230-60	207	254	15
	380/415-50	342	440	1	6	418.0	500	1113.2	527.2	500	500	230-50	198	254	15
	230-50	207	253	1	6	690.6	800	—	857.0	—	800	230-50	207	254	15

LEGEND

- ICF** — Maximum Instantaneous Current Flow during start-up (the point in the starting sequence where the sum of the LRA for the start-up compressor, plus the total RLA for all running compressors is at a maximum)
- LRA** — Locked Rotor Amps
- MCA** — Minimum Circuit Ampacity (for wire sizing)
- MOCP** — Maximum Overcurrent Protection
- RLA** — Rated Load Amps
- WD** — Wye-Delta Start
- XL** — Across-the-Line Start

- Maximum incoming wire size for each terminal block is 500 kcmil.
- Maximum allowable phase imbalance is: voltage, 2%; amps, 5%.
- Use copper conductors only.

6. The MOCP is calculated as follows:

$MOCP = (2.25) (\text{largest RLA}) + \text{the sum of the other RLAs}$. Size the fuse one size down from the result. The RLAs are listed on the nameplate.

The recommended fuse size in amps (RFA) is calculated as follows:

$RFA = (1.50) (\text{largest RLA}) + \text{the sum of the other RLAs}$. Size the fuse one size up from the result. The RLAs are listed on the nameplate.

NOTES:

- Each main power source must be supplied from a field-supplied fused electrical service with a (factory-installed or field-installed) disconnect located in sight from the unit.
- Control circuit power must be supplied from a separate source through a field-supplied disconnect (except for 380/415-50 units). An accessory control transformer may be used to provide control circuit power from the main unit power supply.

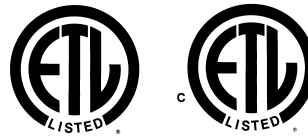



ELECTRICAL DATA, 30HXA UNITS

UNIT 30HXA	UNIT VOLTAGE			POWER SUPPLY QTY. REQD.	NO. POWER SUPPLY CONDUCTORS	UNIT VOLTAGE						CONTROL CIRCUIT			
	V-Hz (3 Ph)	Supplied				MCA	MOCP	ICF		Rec Fuse Size		V-Hz (Single Ph)	Supplied		MCA and MOCP
		Min	Max					XL	WD	XL	WD		Min	Max	
076	230-60	207	253	1	3	291.2	400	—	436.4	—	350	115-60	104	127	15
	208/230-60	187	253	1	3	323.6	450	—	450.8	—	400	115-60	104	127	15
	460-60	414	506	1	3	146.0	200	549.9	217.9	175	175	115-60	104	127	15
	575-60	518	633	1	3	116.8	150	439.9	174.9	150	150	115-60	104	127	15
	380-60	342	418	1	3	177.1	250	614.7	247.7	200	200	230-60	207	254	15
	380/415-50	342	440	1	3	183.4	250	686.5	272.5	225	225	230-50	198	254	15
	230-50	207	253	1	3	303.3	400	—	439.8	—	350	230-50	207	254	15
086	230-60	207	253	1	3	322.8	450	—	496.4	—	400	115-60	104	127	15
	208/230-60	187	253	1	3	358.7	500	—	510.8	—	450	115-60	104	127	15
	460-60	414	506	1	3	161.9	225	644.9	247.9	200	200	115-60	104	127	15
	575-60	518	633	1	3	129.5	175	535.9	198.9	150	150	115-60	104	127	15
	380-60	342	418	1	3	196.2	250	719.7	281.7	225	225	230-60	207	254	15
	380/415-50	342	440	1	3	205.5	300	796.5	307.5	250	250	230-50	198	254	15
	230-50	207	253	1	3	339.7	500	—	495.8	—	400	230-50	207	254	15
096	230-60	207	253	1	3	365.4	500	—	562.4	—	450	115-60	104	127	15
	208/230-60	187	253	1	6	406.1	600	—	576.8	—	500	115-60	104	127	15
	460-60	414	506	1	3	183.4	250	749.9	280.9	225	225	115-60	104	127	15
	575-60	518	633	1	3	146.5	200	599.9	224.9	175	175	115-60	104	127	15
	380-60	342	418	1	3	222.1	300	835.7	317.7	300	300	230-60	207	254	15
	380/415-50	342	440	1	3	231.4	350	937.5	351.5	300	300	230-50	198	254	15
	230-50	207	253	1	6	382.6	500	—	566.8	—	450	230-50	207	254	15
106	230-60	207	253	1	6	416.9	600	—	647.4	—	500	115-60	104	127	15
	208/230-60	187	253	1	6	463.2	700	—	661.8	—	600	115-60	104	127	15
	460-60	414	506	1	3	209.2	300	884.9	323.9	250	250	115-60	104	127	15
	575-60	518	633	1	3	167.2	250	707.9	258.9	200	200	115-60	104	127	15
	380-60	342	418	1	3	253.3	350	984.7	364.7	300	300	230-60	207	254	15
	380/415-50	342	440	1	3	263.3	400	1041.5	384.5	300	300	230-50	198	254	15
	230-50	207	253	1	6	435.1	600	—	619.8	—	500	230-50	207	254	15
116	230-60	207	253	1	6	442.1	600	—	672.7	—	500	115-60	104	127	15
	208/230-60	187	253	1	6	491.3	700	—	689.9	—	600	115-60	104	127	15
	460-60	414	506	1	3	221.9	300	897.6	336.6	300	300	115-60	104	127	15
	575-60	518	633	1	3	177.4	250	718.1	269.1	225	225	115-60	104	127	15
	380-60	342	418	1	3	268.6	400	1000.0	380.0	350	350	230-60	207	254	15
	380/415-50	342	440	1	3	281.0	400	1059.2	402.2	350	350	230-50	198	254	15
	230-50	207	253	1	6	464.2	700	—	648.9	—	600	230-50	207	254	15
126	230-60	207	253	1	6	476.3	700	—	706.8	—	600	115-60	104	127	15
	208/230-60	187	253	1	6	529.2	700	—	727.8	—	600	115-60	104	127	15
	460-60	414	506	1	3	239.1	350	914.8	353.8	300	300	115-60	104	127	15
	575-60	518	633	1	3	191.0	250	731.7	282.7	225	225	115-60	104	127	15
	380-60	342	418	1	3	289.3	400	1020.7	400.7	350	350	230-60	207	254	15
	380/415-50	342	440	1	3	301.7	400	1079.9	422.9	350	350	230-50	198	254	15
	230-50	207	253	1	6	498.5	700	—	683.2	—	600	230-50	207	254	15
136	230-60	207	253	1	6	539.1	800	—	769.8	—	700	115-60	104	127	15
	208/230-60	187	253	1	6	599.1	800	—	790.8	—	700	115-60	104	127	15
	460-60	414	506	1	3	270.7	400	1014.8	385.8	350	350	115-60	104	127	15
	575-60	518	633	1	3	216.2	300	811.7	308.7	250	250	115-60	104	127	15
	380-60	342	418	1	3	327.5	450	1131.7	435.7	400	400	230-60	207	254	15
	380/415-50	342	440	1	3	343.4	500	1345.9	506.9	400	400	230-50	198	254	15
	230-50	207	253	1	6	567.3	800	—	817.2	—	700	230-50	207	254	15
146	230-60	207	253	1	6	580.3	800	—	811.0	—	700	115-60	104	127	15
	208/230-60	187	253	1	6	644.8	800	—	836.5	—	800	115-60	104	127	15
	460-60	414	506	1	3	291.3	400	1035.4	406.4	350	350	115-60	104	127	15
	575-60	518	633	1	3	232.7	300	828.2	325.2	300	300	115-60	104	127	15
	380-60	342	418	1	3	352.5	500	1156.7	460.7	400	400	230-60	207	254	15
	380/415-50	342	440	1	3	368.9	500	1371.4	532.4	450	450	230-50	198	254	15
	230-50	207	253	1	6	609.3	800	—	859.2	—	700	230-50	207	254	15
161	230-60	207	253	1	6	605.6	800	—	955.3	—	700	115-60	104	127	15
	208/230-60	187	253	1	6	672.9	1000	—	978.9	—	800	115-60	104	127	15
	460-60	414	506	1	3	304.0	450	1281.6	477.6	350	350	115-60	104	127	15
	575-60	518	633	1	3	242.9	350	1025.1	382.1	300	300	115-60	104	127	15
	380-60	342	418	1	3	368.0	500	1428.0	539.0	450	450	230-60	207	254	15
	380/415-50	342	440	1	6	384.9	500	1398.4	533.4	450	450	230-50	198	254	15
	230-50	207	253	1	6	635.7	800	—	858.3	—	800	230-50	207	254	15
171	230-60	207	253	1	6	651.5	800	—	1001.2	—	800	115-60	104	127	15
	208/230-60	187	253	1	6	723.9	1000	—	1029.9	—	1000	115-60	104	127	15
	460-60	414	506	1	3	327.0	450	1304.6	500.6	400	400	115-60	104	127	15
	575-60	518	633	1	3	261.4	350	1043.6	400.6	300	300	115-60	104	127	15
	380-60	342	418	1	6	395.9	500	1455.9	566.9	450	450	230-60	207	254	15
	380/415-50	342	440	1	6	413.2	600	1426.7	561.7	500	500	230-50	198	254	15
	230-50	207	253	1	6	682.6	1000	—	905.2	—	800	230-50	207	254	15

Electrical data (cont)



ELECTRICAL DATA, 30HXA UNITS (cont)

UNIT 30HXA	UNIT VOLTAGE			POWER SUPPLY QTY. REQ'D.	NO. POWER SUPPLY CONDUCTORS	UNIT VOLTAGE						CONTROL CIRCUIT			
	V-Hz (3 Ph)	Supplied				MCA	MOCP	ICF		Rec Fuse Size		V-Hz (Single Ph)	Supplied		MCA and MOCP
		Min	Max					XL	WD	XL	WD		Min	Max	
186	230-60	207	253	1	6	707.9	1000	—	1057.6	—	800	115-60	104	127	15
	208/230-60											115-60	104	127	15
	Ckt A	187	253	1	6	437.0	700	—	743.0	—	600				
	Ckt B	187	253	1	6	437.0	700	—	743.0	—	600				
	460-60	414	506	1	3	355.3	500	1332.9	528.9	400	400	115-60	104	127	15
	575-60	518	633	1	3	284.0	400	1066.2	423.2	350	350	115-60	104	127	15
	380-60	342	418	1	6	430.2	600	1490.2	601.2	500	500	230-60	207	254	15
	380/415-50	342	440	1	6	452.7	600	1466.2	601.2	600	600	230-50	198	254	15
230-50	207	253	1	6	747.7	1000	—	970.3	—	1000	230-50	207	254	15	
206	230-60	207	253	1	6	468.6	700.0	—	726.8	—	600	115-60	104	127	15
	Ckt A	207	253	1	3	379.8	600.0	—	743.0	—	500				
	Ckt B	207	253	1	3	379.8	600.0	—	743.0	—	500				
	208/230-60											115-60	104	127	15
	Ckt A	187	253	1	6	520.6	800.0	—	743.0	—	600				
	Ckt B	187	253	1	6	422.0	700.0	—	743.0	—	600				
	460-60	414	506	1	6	400.1	500.0	1377.7	573.7	450	450	115-60	104	127	15
	575-60	518	633	1	3	319.9	400.0	1102.1	459.1	400	400	115-60	104	127	15
	380-60	342	418	1	6	484.4	600.0	1544.4	655.4	600	600	230-60	207	254	15
	380/415-50	342	440	1	6	505.2	700.0	1518.7	653.7	600	600	230-50	198	254	15
230-50											230-50	207	254	15	
Ckt A	207	253	1	6	486.0	700.0	—	771.0	—	600					
Ckt B	207	253	1	6	415.4	700.0	—	638.0	—	500					
246	230-60	207	253	1	6	592.1	800.0	—	955.3	—	700	115-60	104	127	15
	Ckt A	207	253	1	3	379.8	600.0	—	743.0	—	500				
	Ckt B	207	253	1	3	379.8	600.0	—	743.0	—	500				
	208/230-60											115-60	104	127	15
	Ckt A	187	253	1	6	657.9	800.0	—	978.9	—	800				
	Ckt B	187	253	1	6	422.0	700.0	—	743.0	—	600				
	460-60	414	506	1	6	461.9	600.0	1439.5	635.5	600	600	115-60	104	127	15
	575-60	518	633	1	3	369.1	450.0	1151.3	508.3	450	450	115-60	104	127	15
	380-60	342	418	1	6	559.2	700.0	1619.2	730.2	700	700	230-60	207	254	15
	380/415-50	342	440	1	6	586.1	700.0	1599.6	734.6	700	700	230-50	198	254	15
230-50											230-50	207	254	15	
Ckt A	207	253	1	6	635.7	800.0	—	858.3	—	800					
Ckt B	207	253	1	6	415.4	700.0	—	638.0	—	500					
261	230-60	207	253	1	6	638.0	800.0	—	1001.2	—	800	115-60	104	127	15
	Ckt A	207	253	1	3	379.8	600.0	—	743.0	—	500				
	Ckt B	207	253	1	3	379.8	600.0	—	743.0	—	500				
	208/230-60											115-60	104	127	15
	Ckt A	187	253	1	6	708.9	1000.0	—	1029.9	—	800				
	Ckt B	187	253	1	6	422.0	700.0	—	743.0	—	600				
	460-60	414	506	1	6	484.9	600.0	1462.5	658.5	600	600	115-60	104	127	15
	575-60	518	633	1	6	387.6	500.0	1169.8	526.8	450	450	115-60	104	127	15
	380-60	342	418	1	6	587.1	700.0	1647.1	758.1	700	700	230-60	207	254	15
	380/415-50	342	440	1	6	614.4	800.0	1627.9	762.9	700	700	230-50	198	254	15
230-50											230-50	207	254	15	
Ckt A	207	253	1	6	682.6	1000.0	—	905.2	—	800					
Ckt B	207	253	1	6	415.4	700.0	—	638.0	—	500					
271	230-60	207	253	1	6	683.6	800.0	—	1046.8	—	800	115-60	104	127	15
	Ckt A	207	253	1	3	379.8	600.0	—	743.0	—	500				
	Ckt B	207	253	1	3	379.8	600.0	—	743.0	—	500				
	208/230-60											115-60	104	127	15
	Ckt A	187	253	1	6	759.6	1000.0	—	1080.6	—	1000				
	Ckt B	187	253	1	6	422.0	700.0	—	743.0	—	600				
	460-60	414	506	1	6	513.2	600.0	1490.8	686.8	600	600	115-60	104	127	15
	575-60	518	633	1	6	410.2	500.0	1192.4	549.4	450	450	115-60	104	127	15
	380-60	342	418	1	6	621.4	800.0	1681.4	792.4	700	700	230-60	207	254	15
	380/415-50	342	440	1	6	653.9	800.0	1667.4	802.4	800	800	230-50	198	254	15
230-50											230-50	207	254	15	
Ckt A	207	253	1	6	747.7	1000.0	—	970.3	—	1000					
Ckt B	207	253	1	6	415.4	700.0	—	638.0	—	500					

LEGEND

- ICF** — Maximum Instantaneous Current Flow during start-up (the point in the starting sequence where the sum of the LRA for the start-up compressor, plus the total RLA for all running compressors is at a maximum)
- LRA** — Locked Rotor Amps
- MCA** — Minimum Circuit Ampacity (for wire sizing)
- MOCP** — Maximum Overcurrent Protection
- RLA** — Rated Load Amps
- WD** — Wye-Delta Start
- XL** — Across-the-Line Start

NOTES:

1. Each main power source must be supplied from a field-supplied fused electrical service with a (factory-installed or field-installed) disconnect located in sight from the unit.
2. Control circuit power must be supplied from a separate source through a field-supplied disconnect (except for 380/415-50 units). An accessory

control transformer may be used to provide control circuit power from the main unit power supply.

3. Maximum incoming wire size for each terminal block is 500 kcmil.
4. Maximum allowable phase imbalance is: voltage, 2%; amps, 5%.
5. Use copper conductors only.
6. The MOCP is calculated as follows:

MOCP = (2.25) (largest RLA) + the sum of the other RLAs. Size the fuse one size down from the result. The RLAs are listed on the nameplate.

The recommended fuse size in amps (RFA) is calculated as follows:

RFA = (1.50) (largest RLA) + the sum of the other RLAs. Size the fuse one size up from the result. The RLAs are listed on the nameplate.





COMPRESSOR ELECTRICAL DATA, 30HXC UNITS

UNIT SIZE 30HXC	NAMEPLATE V-Hz (3 Phase)	COMPRESSOR NUMBERS			
		A1		B1	
		RLA	LRA	RLA	LRA
076-XL	208/230-60	*	*	*	*
	230-60	*	*	*	*
	460-60	44.3	330	44.3	330
	575-60	35.4	264	35.4	264
	380-60	53.7	365	53.7	365
	230-50	*	*	*	*
076-WD	380/415-50	55.8	344	55.8	344
	208/230-60	98.1	209	98.1	209
	230-60	88.3	209	88.3	209
	460-60	44.3	104	44.3	104
	575-60	35.4	83	35.4	83
	380-60	53.7	115	53.7	115
086-XL	230-50	92.1	174	92.1	174
	380/415-50	55.8	109	55.8	109
	208/230-60	*	*	*	*
	230-60	*	*	*	*
	460-60	53.6	330	44.3	330
	575-60	42.8	264	35.4	264
086-WD	380-60	64.9	365	53.7	365
	230-50	*	*	*	*
	380/415-50	67.7	423	55.8	344
	208/230-60	118.6	209	98.1	209
	230-60	106.7	209	88.3	209
	460-60	53.6	104	44.3	104
096-XL	575-60	42.8	83	35.4	83
	380-60	64.9	115	53.7	115
	230-50	111.8	213	92.1	174
	380/415-50	67.7	134	55.8	109
	208/230-60	*	*	*	*
	230-60	*	*	*	*
096-WD	460-60	65.5	405	44.3	330
	575-60	52.3	324	35.4	264
	380-60	79.2	448	53.7	365
	230-50	*	*	*	*
	380/415-50	81.7	506	55.8	344
	208/230-60	144.9	256	98.1	209
106-XL	230-60	130.4	256	88.3	209
	460-60	65.5	128	44.3	104
	575-60	52.3	102	35.4	83
	380-60	79.2	141	53.7	115
	230-50	134.9	255	92.1	174
	380/415-50	81.7	160	55.8	109
106-WD	208/230-60	*	*	*	*
	230-60	*	*	*	*
	460-60	79.2	485	44.3	330
	575-60	63.3	388	35.4	264
	380-60	95.9	536	53.7	365
	230-50	*	*	*	*
106-XL	380/415-50	97.8	605	55.8	344
	208/230-60	175.4	307	98.1	209
	230-60	157.9	307	88.3	209
	460-60	79.2	153	44.3	104
	575-60	63.3	123	35.4	83
	380-60	95.9	169	53.7	115
106-WD	230-50	161.7	305	92.1	174
	380/415-50	97.8	191	55.8	109

LEGEND

- LRA** — Locked Rotor Amps
- RLA** — Rated Load Amps
- WD** — Wye-Delta Start
- XL** — Across-the-Line Start

*Units are shipped with wye-delta start as standard. Across-the-line start is not available.

Electrical data (cont)



COMPRESSOR ELECTRICAL DATA, 30HXC UNITS (cont)

UNIT SIZE 30HXC	NAMEPLATE V-Hz (3 Phase)	COMPRESSOR NUMBERS			
		A1		B1	
		RLA	LRA	RLA	LRA
116-XL	208/230-60	*	*	*	*
	230-60	*	*	*	*
	460-60	79.2	485	53.6	330
	575-60	63.3	388	42.8	264
	380-60	95.9	536	64.9	365
	230-50	*	*	*	*
116-WD	380/415-50	97.8	605	67.7	423
	208/230-60	175.4	307	118.6	209
	230-60	157.9	307	106.7	209
	460-60	79.2	153	53.6	104
	575-60	63.3	123	42.8	83
	380-60	95.9	169	64.9	115
126-XL	230-50	161.7	305	111.8	213
	380/415-50	97.8	191	67.7	134
	208/230-60	*	*	*	*
	230-60	*	*	*	*
	460-60	79.2	485	65.5	405
	575-60	63.3	388	52.3	324
126-WD	380-60	95.9	536	79.2	448
	230-50	*	*	*	*
	380/415-50	97.8	605	81.7	506
	208/230-60	175.4	307	144.9	256
	230-60	157.9	307	130.4	256
	460-60	79.2	153	65.5	128
136-XL	575-60	63.3	123	52.3	102
	380-60	95.9	169	79.2	141
	230-50	161.7	305	134.9	255
	380/415-50	97.8	191	81.7	160
	208/230-60	*	*	*	*
	230-60	*	*	*	*
136-WD	460-60	94.6	580	65.5	405
	575-60	75.8	484	52.3	324
	380-60	114.9	641	79.2	448
	230-50	*	*	*	*
	380/415-50	118.8	715	81.7	506
	208/230-60	210.0	367	144.9	256
146-XL	230-60	189.0	367	130.4	256
	460-60	94.6	183	65.5	128
	575-60	75.8	147	52.3	102
	380-60	114.9	203	79.2	141
	230-50	196.3	361	134.9	255
	380/415-50	118.8	226	81.7	160
146-WD	208/230-60	*	*	*	*
	230-60	*	*	*	*
	460-60	94.6	580	79.2	485
	575-60	75.8	484	63.3	388
	380-60	114.9	641	95.9	536
	230-50	*	*	*	*
146-XL	380/415-50	118.8	715	97.8	605
	208/230-60	210.0	367	175.4	307
	230-60	189.0	367	157.9	307
	460-60	94.6	183	79.2	153
	575-60	75.8	147	63.3	123
	380-60	114.9	203	95.9	169
146-WD	230-50	196.3	361	161.7	305
	380/415-50	118.8	226	97.8	191

LEGEND

- LRA** — Locked Rotor Amps
- RLA** — Rated Load Amps
- WD** — Wye-Delta Start
- XL** — Across-the-Line Start

*Units are shipped with wye-delta start as standard. Across-the-line start is not available.



COMPRESSOR ELECTRICAL DATA, 30HXC UNITS (cont)

UNIT SIZE 30HXC	NAMEPLATE V-Hz (3 Phase)	COMPRESSOR NUMBERS			
		A1		B1	
		RLA	LRA	RLA	LRA
161-XL	208/230-60	*	*	*	*
	230-60	*	*	*	*
	460-60	103.1	685	71.2	525
	575-60	82.4	548	56.9	420
	380-60	124.8	757	86.2	580
	230-50	*	*	*	*
161-WD	380/415-50	128.6	856	88.2	600
	208/230-60	228.8	433	157.6	350
	230-60	205.5	433	141.8	350
	460-60	103.1	216	71.2	175
	575-60	82.4	173	56.9	140
	380-60	124.8	239	86.2	193
171-XL	230-50	212.5	432	145.7	348
	380/415-50	128.6	270	88.2	200
	208/230-60	*	*	*	*
	230-60	*	*	*	*
	460-60	86.1	580	103.1	685
	575-60	68.8	484	82.4	548
171-WD	380-60	104.2	641	124.8	757
	230-50	*	*	*	*
	380/415-50	105.8	715	128.6	856
	208/230-60	190.6	367	228.8	433
	230-60	171.5	367	205.5	433
	460-60	86.1	183	103.1	216
186-XL	575-60	68.8	147	82.4	173
	380-60	104.2	203	124.8	239
	230-50	174.8	361	212.5	432
	380/415-50	105.8	233	128.6	270
	208/230-60	*	*	*	*
	230-60	*	*	*	*
186-WD	460-60	103.1	685	103.1	685
	575-60	82.4	548	82.4	548
	380-60	124.8	757	124.8	757
	230-50	*	*	*	*
	380/415-50	128.6	856	128.6	856
	208/230-60	228.8	433	228.8	433
186-XL	230-60	205.5	433	205.5	433
	460-60	103.1	216	103.1	216
	575-60	82.4	173	82.4	173
	380-60	124.8	239	124.8	239
	230-50	212.5	432	212.5	432
	380/415-50	128.6	270	128.6	270

LEGEND

- LRA** — Locked Rotor Amps
- RLA** — Rated Load Amps
- WD** — Wye-Delta Start
- XL** — Across-the-Line Start

*Units are shipped with wye-delta start as standard. Across-the-line start is not available.

Electrical data (cont)



COMPRESSOR ELECTRICAL DATA, 30HXC UNITS (cont)

UNIT SIZE 30HXC	NAMEPLATE V-Hz (3 Phase)	COMPRESSOR NUMBERS					
		A1		A2		B1	
		RLA	LRA	RLA	LRA	RLA	LRA
206-XL	208/230-60	*	*	*	*	*	*
	230-60	*	*	*	*	*	*
	460-60	86.1	580	48.2	350	103.1	685
	575-60	68.8	484	38.6	280	82.4	548
	380-60	104.2	641	58.4	390	124.8	757
	230-50	*	*	*	*	*	*
206-WD	380/415-50	105.8	715	55.8	344	128.6	856
	208/230-60	190.6	367	106.8	233	228.8	433
	230-60	171.5	367	96.1	233	205.5	433
	460-60	86.1	183	48.2	117	103.1	216
	575-60	68.8	147	38.6	93	82.4	173
	380-60	104.2	203	58.4	130	124.8	239
246-XL	230-50	174.8	361	99.4	260	212.5	432
	380/415-50	105.8	226	60.2	150	128.6	270
	208/230-60	*	*	*	*	*	*
	230-60	*	*	*	*	*	*
	460-60	103.1	685	71.2	485	103.1	685
	575-60	82.4	548	56.9	388	82.4	548
246-WD	380-60	124.8	757	86.2	536	124.8	757
	230-50	*	*	*	*	*	*
	380/415-50	128.6	856	88.2	605	128.6	856
	208/230-60	228.8	433	157.6	307	228.8	433
	230-60	205.5	433	141.8	307	205.5	433
	460-60	103.1	216	71.2	153	103.1	216
261-XL	575-60	82.4	173	56.9	123	82.4	173
	380-60	124.8	239	86.2	169	124.8	239
	230-50	212.5	432	145.7	305	212.5	432
	380/415-50	128.6	270	88.2	191	128.6	270
	208/230-60	*	*	*	*	*	*
	230-60	*	*	*	*	*	*
261-WD	460-60	103.1	685	86.1	580	103.1	685
	575-60	82.4	548	68.8	484	82.4	548
	380-60	124.8	757	104.2	641	124.8	757
	230-50	*	*	*	*	*	*
	380/415-50	128.6	856	105.8	715	128.6	856
	208/230-60	228.8	433	190.6	367	228.8	433
271-XL	230-60	205.5	433	171.5	367	205.5	433
	460-60	103.1	216	86.1	183	103.1	216
	575-60	82.4	173	68.8	147	82.4	173
	380-60	124.8	239	104.2	203	124.8	239
	230-50	212.5	432	174.8	361	212.5	432
	380/415-50	128.6	270	105.8	226	128.6	270
271-WD	208/230-60	*	*	*	*	*	*
	230-60	*	*	*	*	*	*
	460-60	103.1	685	103.1	685	103.1	685
	575-60	82.4	548	82.4	548	82.4	548
	380-60	124.8	757	124.8	757	124.8	757
	230-50	*	*	*	*	*	*
271-XL	380/415-50	128.6	856	128.6	856	128.6	856
	208/230-60	228.8	433	228.8	433	228.8	433
	230-60	205.5	433	205.5	433	205.5	433
	460-60	103.1	216	103.1	216	103.1	216
	575-60	82.4	173	82.4	173	82.4	173
	380-60	124.8	239	124.8	239	124.8	239
271-WD	230-50	212.5	432	212.5	432	212.5	432
	380/415-50	128.6	270	128.6	270	128.6	270

LEGEND

- LRA** — Locked Rotor Amps
- RLA** — Rated Load Amps
- WD** — Wye-Delta Start
- XL** — Across-the-Line Start

*Units are shipped with wye-delta start as standard. Across-the-line start is not available.



COMPRESSOR ELECTRICAL DATA, 30HXA UNITS

UNIT SIZE 30HXA	NAMEPLATE V-Hz (3 Phase)	COMPRESSOR NUMBERS			
		A1		B1	
		RLA	LRA	RLA	LRA
076-XL	208/230-60	*	*	*	*
	230-60	*	*	*	*
	460-60	64.9	485	64.9	485
	575-60	51.9	388	51.9	388
	380-60	78.7	536	78.7	536
	230-50	*	*	*	*
076-WD	380/415-50	81.5	605	81.5	605
	208/230-60	143.8	307	143.8	307
	230-60	129.4	307	129.4	307
	460-60	64.9	153	64.9	153
	575-60	51.9	123	51.9	123
	380-60	78.7	169	78.7	169
086-XL	230-50	134.8	305	134.8	305
	380/415-50	81.5	191	81.5	191
	208/230-60	*	*	*	*
	230-60	*	*	*	*
	460-60	77.6	580	64.9	485
	575-60	62.1	484	51.9	388
086-WD	380-60	94.0	641	78.7	536
	230-50	*	*	*	*
	380/415-50	99.2	715	81.5	605
	208/230-60	171.9	367	143.8	307
	230-60	154.7	367	129.4	307
	460-60	77.6	183	64.9	153
096-XL	575-60	62.1	147	51.9	123
	380-60	94.0	203	78.7	169
	230-50	163.9	361	134.8	305
	380/415-50	99.2	226	81.5	191
	208/230-60	*	*	*	*
	230-60	*	*	*	*
096-WD	460-60	94.8	685	64.9	485
	575-60	75.7	548	51.9	388
	380-60	114.7	757	78.7	536
	230-50	*	*	*	*
	380/415-50	119.9	856	81.5	605
	208/230-60	209.8	433	143.8	307
106-XL	230-60	188.8	433	129.4	307
	460-60	94.8	216	64.9	153
	575-60	75.7	173	51.9	123
	380-60	114.7	239	78.7	169
	230-50	198.2	432	134.8	305
	380/415-50	119.9	270	81.5	191
106-WD	208/230-60	*	*	*	*
	230-60	*	*	*	*
	460-60	115.4	820	64.9	485
	575-60	92.2	656	51.9	388
	380-60	139.7	906	78.7	536
	230-50	*	*	*	*
106-XL	380/415-50	145.4	960	81.5	605
	208/230-60	255.5	518	143.8	307
	230-60	230.0	518	129.4	307
	460-60	115.4	259	64.9	153
	575-60	92.2	207	51.9	123
	380-60	139.7	286	78.7	169
106-WD	230-50	240.2	485	134.8	305
	380/415-50	145.4	303	81.5	191

LEGEND

- LRA** — Locked Rotor Amps
- RLA** — Rated Load Amps
- WD** — Wye-Delta Start
- XL** — Across-the-Line Start

*Units are shipped with wye-delta start as standard. Across-the-line start is not available.

Electrical data (cont)



COMPRESSOR ELECTRICAL DATA, 30HXA UNITS (cont)

UNIT SIZE 30HXA	NAMEPLATE V-Hz (3 Phase)	COMPRESSOR NUMBERS			
		A1		B1	
		RLA	LRA	RLA	LRA
116-XL	208/230-60	*	*	*	*
	230-60	*	*	*	*
	460-60	115.4	820	77.6	580
	575-60	92.2	656	62.1	484
	380-60	139.7	906	94.0	641
	230-50	*	*	*	*
116-WD	380/415-50	145.4	960	99.2	715
	208/230-60	255.5	518	171.9	367
	230-60	230.0	518	154.7	367
	460-60	115.4	259	77.6	183
	575-60	92.2	207	62.1	147
	380-60	139.7	286	94.0	203
126-XL	230-50	240.2	485	163.9	361
	380/415-50	145.4	303	99.2	226
	208/230-60	*	*	*	*
	230-60	*	*	*	*
	460-60	115.4	820	94.8	685
	575-60	92.2	656	75.7	548
126-WD	380-60	139.7	906	114.7	757
	230-50	*	*	*	*
	380/415-50	145.4	960	119.9	856
	208/230-60	255.5	518	209.8	433
	230-60	230.0	518	188.8	433
	460-60	115.4	259	94.8	216
136-XL	575-60	92.2	207	75.7	173
	380-60	139.7	286	114.7	239
	230-50	240.2	485	198.2	432
	380/415-50	145.4	303	119.9	270
	208/230-60	*	*	*	*
	230-60	*	*	*	*
136-WD	460-60	140.7	920	94.8	685
	575-60	112.4	736	75.7	548
	380-60	170.2	1017	114.7	757
	230-50	*	*	*	*
	380/415-50	178.8	1226	119.9	856
	208/230-60	311.4	581	209.8	433
146-XL	230-60	280.3	581	188.8	433
	460-60	140.7	291	94.8	216
	575-60	112.4	233	75.7	173
	380-60	170.2	321	114.7	239
	230-50	295.3	619	198.2	432
	380/415-50	178.8	387	119.9	270
146-WD	208/230-60	*	*	*	*
	230-60	*	*	*	*
	460-60	140.7	920	115.4	820
	575-60	112.4	736	92.2	656
	380-60	170.2	1017	139.7	906
	230-50	*	*	*	*
146-XL	380/415-50	178.8	1226	145.4	960
	208/230-60	311.4	581	255.5	518
	230-60	280.3	581	230.0	518
	460-60	140.7	291	115.4	259
	575-60	112.4	233	92.2	207
	380-60	170.2	321	139.7	286
146-WD	230-50	295.3	619	240.2	485
	380/415-50	178.8	387	145.4	303

LEGEND

- LRA** — Locked Rotor Amps
- RLA** — Rated Load Amps
- WD** — Wye-Delta Start
- XL** — Across-the-Line Start

*Units are shipped with wye-delta start as standard. Across-the-line start is not available.



COMPRESSOR ELECTRICAL DATA, 30HXA UNITS (cont)

UNIT SIZE 30HXA	NAMEPLATE V-Hz (3 Phase)	COMPRESSOR NUMBERS			
		A1		B1	
		RLA	LRA	RLA	LRA
161-XL	208/230-60	*	*	*	*
	230-60	*	*	*	*
	460-60	157.9	1175	106.6	790
	575-60	126.2	940	85.1	630
	380-60	191.2	1299	129.0	870
	230-50	*	*	*	*
161-WD	380/415-50	201.2	1265	133.4	1045
	208/230-60	349.6	743	235.9	527
	230-60	314.6	743	212.3	527
	460-60	157.9	371	106.6	263
	575-60	126.2	297	85.1	211
	380-60	191.2	410	129.0	290
171-XL	230-50	332.3	638	220.3	607
	380/415-50	201.2	400	133.4	348
	208/230-60	*	*	*	*
	230-60	*	*	*	*
	460-60	129.6	920	157.9	1175
	575-60	103.6	736	126.2	940
171-WD	380-60	156.9	1017	191.2	1299
	230-50	*	*	*	*
	380/415-50	161.7	1226	201.2	1265
	208/230-60	286.9	581	349.6	743
	230-60	258.2	581	314.6	743
	460-60	129.6	291	157.9	371
186-XL	575-60	103.6	233	126.2	297
	380-60	156.9	321	191.2	410
	230-50	267.2	619	332.3	638
	380/415-50	161.7	387	201.2	400
	208/230-60	*	*	*	*
	230-60	*	*	*	*
186-WD	460-60	157.9	1175	157.9	1175
	575-60	126.2	940	126.2	940
	380-60	191.2	1299	191.2	1299
	230-50	*	*	*	*
	380/415-50	201.2	1265	201.2	1265
	208/230-60	349.6	743	349.6	743
186-XL	230-60	314.6	743	314.6	743
	460-60	157.9	371	157.9	371
	575-60	126.2	297	126.2	297
	380-60	191.2	410	191.2	410
	230-50	332.3	638	332.3	638
	380/415-50	201.2	400	201.2	400

LEGEND

- LRA** — Locked Rotor Amps
- RLA** — Rated Load Amps
- WD** — Wye-Delta Start
- XL** — Across-the-Line Start

*Units are shipped with wye-delta start as standard. Across-the-line start is not available.

Electrical data (cont)



COMPRESSOR ELECTRICAL DATA, 30HXA UNITS (cont)

UNIT SIZE 30HXA	NAMEPLATE V-Hz (3 Phase)	COMPRESSOR NUMBERS					
		A1		A2		B1	
		RLA	LRA	RLA	LRA	RLA	LRA
206-XL	208/230-60	*	*	*	*	*	*
	230-60	*	*	*	*	*	*
	460-60	129.6	920	73.1	580	157.9	1175
	575-60	103.6	736	58.5	484	126.2	940
	380-60	156.9	1017	88.5	641	191.2	1299
	230-50	*	*	*	*	*	*
206-WD	380/415-50	161.7	1226	92.0	715	201.2	1265
	208/230-60	286.9	581	162.0	367	337.6	743
	230-60	258.2	581	145.8	367	303.8	743
	460-60	129.6	291	73.1	183	157.9	371
	575-60	103.6	233	58.5	147	126.2	297
	380-60	156.9	321	88.5	203	191.2	410
246-XL	230-50	267.2	619	152.0	361	332.3	638
	380/415-50	161.7	387	92.0	226	201.2	400
	208/230-60	*	*	*	*	*	*
	230-60	*	*	*	*	*	*
	460-60	157.9	1175	106.6	820	157.9	1175
	575-60	126.2	940	85.1	656	126.2	940
246-WD	380-60	191.2	1299	129.0	906	191.2	1299
	230-50	*	*	*	*	*	*
	380/415-50	201.2	1265	133.4	960	201.2	1265
	208/230-60	337.6	743	235.9	518	337.6	743
	230-60	303.8	743	212.3	518	303.8	743
	460-60	157.9	371	106.6	259	157.9	371
261-XL	575-60	126.2	297	85.1	207	126.2	297
	380-60	191.2	410	129.0	286	191.2	410
	230-50	332.3	638	220.3	485	332.3	638
	380/415-50	201.2	400	133.4	303	201.2	400
	208/230-60	*	*	*	*	*	*
	230-60	*	*	*	*	*	*
261-WD	460-60	157.9	1175	129.6	920	157.9	1175
	575-60	126.2	940	103.6	736	126.2	940
	380-60	191.2	1299	156.9	1017	191.2	1299
	230-50	*	*	*	*	*	*
	380/415-50	201.2	1265	161.7	1226	201.2	1265
	208/230-60	337.6	743	286.9	581	337.6	743
271-XL	230-60	303.8	743	258.2	581	303.8	743
	460-60	157.9	371	129.6	291	157.9	371
	575-60	126.2	297	103.6	233	126.2	297
	380-60	191.2	410	156.9	321	191.2	410
	230-50	332.3	638	267.2	619	332.3	638
	380/415-50	201.2	400	161.7	387	201.2	400
271-WD	208/230-60	*	*	*	*	*	*
	230-60	*	*	*	*	*	*
	460-60	157.9	1175	157.9	1175	157.9	1175
	575-60	126.2	940	126.2	940	126.2	940
	380-60	191.2	1299	191.2	1299	191.2	1299
	230-50	*	*	*	*	*	*
271-XL	380/415-50	201.2	1265	201.2	1265	201.2	1265
	208/230-60	337.6	743	337.6	743	337.6	743
	230-60	303.8	743	303.8	743	303.8	743
	460-60	157.9	371	157.9	371	157.9	371
	575-60	126.2	297	126.2	297	126.2	297
	380-60	191.2	410	191.2	410	191.2	410
271-WD	230-50	332.3	638	332.3	638	332.3	638
	380/415-50	201.2	400	201.2	400	201.2	400

LEGEND

- LRA** — Locked Rotor Amps
- RLA** — Rated Load Amps
- WD** — Wye-Delta Start
- XL** — Across-the-Line Start

*Units are shipped with wye-delta start as standard. Across-the-line start is not available.

Controls



The standard microprocessor-based control in the 30HX units provides the following functions:

- leaving fluid temperature control (using both entering and leaving fluid sensors)
- 7-day time sequence of both pump and chiller
- temperature reset from return fluid (standard) or from outdoor ambient (accessory), occupied space temperature (accessory), 4 to 20 mA signal (accessory), or via the optional Carrier Comfort Network (CCN)
- automatic compressor lead-lag switching based on compressor accumulated run times and number of cycles
- automatic temperature range across the cooler adjustment
- fully automatic control of the chiller components

A 4-line, 20-character per line display is used to accomplish the following (see figure below):

- set schedules and set points
- identify operating mode
- display current temperatures and pressures being used by the control for internal calculations
- identify abnormal (alarm or alert) conditions

Sequence of operation

The control has a 44 F (6.2 C) leaving fluid temperature (LWT) set point as shipped from the factory. If temperature reset or demand limiting is in effect, this set point may change.

Start-up — The chiller will start when the circulating pump is energized. (If the flow switch is applied, the chiller starts after the flow has been proven.) The compressor starts unloaded.

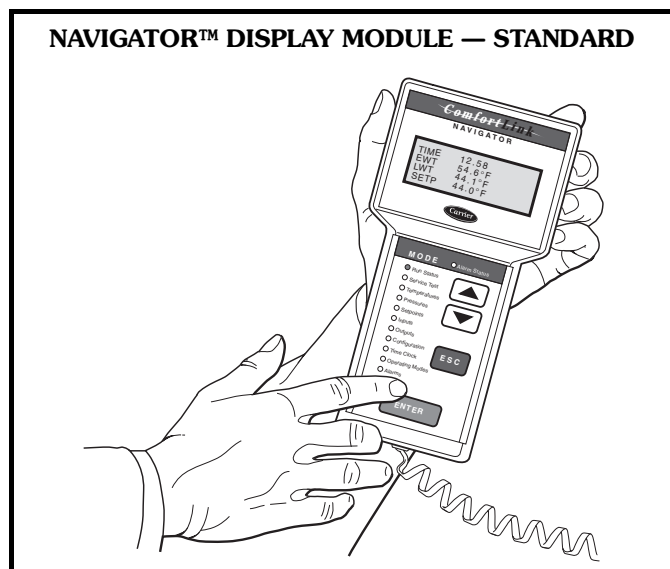

NOTE: Which compressor starts first is determined by the automatic lead/lag feature.

If the entering fluid temperature is 85 F (29 C) or higher, the maximum operating pressure (MOP) feature limits the suction pressure to keep the chiller on line.

Normal operation — The entering fluid temperature sensor monitors changes in entering fluid temperature to anticipate changes in the cooling load. Based on leaving fluid temperature, the control adds or subtracts capacity to maintain a constant leaving fluid temperature.

Dual chiller control — The Dual Chiller Routine is available for the control of two units supplying chilled fluid on a common loop.

In parallel flow applications, an additional leaving fluid temperature thermistor must be installed and connected to the lead chiller.

Transition to off — The chiller unloads once the “time-to-stop” signal has been given. This signal can be either internal or external.

Safeties — The 30HX control as shipped from the factory automatically deenergizes any active compressor that experiences any of the following:

- electrical overload
- thermal overload protection
- high pressure
- low oil pressure
- loss of refrigerant charge
- loss of phase protection
- reverse rotation (control prevents compressor start)
- current imbalance
- ground current
- low chilled fluid temperature

Additional information

Detailed information on controls and operation is available in the Controls, Start-Up, Operation and Troubleshooting guide included with each unit. Packaged Service Training programs are also available. Contact your Carrier representative for more information.

Guide specifications



Water-Cooled and Condenserless HVAC Guide Specifications

Size Range: **75 to 265 Tons (264 to 931 kW)**

Carrier Model Number: **30HXA — Condenserless
30HXC — Water-Cooled**

Part 1 — General

1.01 SYSTEM DESCRIPTION

Microprocessor controlled water-cooled (30HXC) or condenserless (30HXA) liquid chiller utilizing screw compressors and electronic expansion valves.

1.02 QUALITY ASSURANCE

- A. Unit shall be rated in accordance with ARI Standard 550/590-98 (U.S.A.). The 60 Hz 30HXC units shall be ARI certified for performance.
- B. Unit construction shall comply with ASHRAE 15 Safety Code, NEC, and ASME applicable codes (U.S.A. codes).
- C. Unit shall be manufactured at an ISO 9001:2000 registered facility.
- D. 208/230 v, 230 v, 460 v, 575 v, 60 Hz units shall be constructed in accordance with UL or UL Canada standards and shall be tested and listed by ETL or ETL, Canada, as conforming to those standards. Units shall carry the ETL and ETL, Canada, labels.

1.03 DELIVERY, STORAGE, AND HANDLING

- A. Unit controls shall be capable of withstanding 150 F (66 C) storage temperatures in the control compartment.
- B. Unit shall be stored and handled per unit manufacturer's recommendations.

Part 2 — Products

2.01 EQUIPMENT

A. General:

Factory assembled, single-piece, water-cooled (30HXC) or condenserless (30HXA) liquid chiller with dual (2) independent refrigerant circuits. Contained within the unit cabinet shall be all factory wiring, piping, controls, refrigerant charge (HFC-134a) (30HXA units shipped with holding charge only), and special features required prior to field start-up.

B. Compressors:

1. Semi-hermetic twin-screw compressors with internal muffler and check valve.
2. Each compressor shall be equipped with a discharge shutoff valve.

C. Cooler (Evaporator):

1. Shall be tested and stamped in accordance with ASME Code (U.S.A.) for a refrigerant working-side pressure of 220 psig (1408 kPa). Waterside pressure rating shall be 300 psig (2068 kPa). In Canada, maximum waterside pressure shall be 250 psig (1725 kPa), per the Canadian National Registry.

2. Shall be mechanically cleanable shell-and-tube type with removable heads.
3. Tubes shall be internally enhanced, seamless-copper type, and shall be rolled into tube sheets.
4. Shall be equipped with Victaulic fluid connections.
5. Shell shall be insulated with 3/4-in. (19-mm) closed-cell, polyvinyl chloride foam with a maximum K factor of 0.28. Heads may require field insulation.
6. Shall have a cooler drain and vent.
7. Design shall incorporate 2 independent refrigerant circuits.
8. Shall include isolation valves to allow isolation of the refrigerant charge in either the evaporator or the condenser.
9. Shall be equipped with factory-installed thermal dispersion chilled fluid flow switch.

D. Condenser (30HXC units):

1. Shall be tested and stamped in accordance with ASME code (U.S.A.) for a refrigerant working-side pressure of 220 psig (1408 kPa). Waterside pressure rating shall be 300 psig (2068 kPa). In Canada, maximum waterside pressure shall be 250 psig (1725 kPa), per the Canadian National Registry.
2. Shall be mechanically cleanable shell-and-tube type with removable heads.
3. Tubes shall be internally enhanced, seamless-copper type, and shall be rolled into tube sheets.
4. Shall be equipped with Victaulic water connections.
5. Design shall incorporate 2 independent refrigerant circuits.

E. Oil Separator (30HXA Units):

1. Shall be tested and stamped in accordance with ASME Code (U.S.A.) for a refrigerant working-side pressure of 320 psig (2206 kPa).
2. Design shall incorporate 2 independent refrigerant circuits.

F. Refrigeration Components:

Refrigerant circuit components shall include oil separator, high and low side pressure relief devices, discharge and liquid line shutoff valves, filter drier, moisture indicating sight glass, expansion valve, refrigerant economizer (unit sizes 161-271), and complete charge of compressor oil. The 30HXC units shall have a complete operating charge of refrigerant HFC-134a; 30HXA units shall have a holding charge only.

G. Controls, Safeties, and Diagnostics:

1. Controls:

- a. Unit controls shall include the following minimum components:

- 1) Microprocessor with non-volatile memory. Battery backup system shall not be accepted.
- 2) Power and control circuit terminal blocks.
- 3) ON/OFF control switch.
- 4) Replaceable solid-state relay panels.
- 5) Thermistor installed to measure saturated condensing temperature, cooler saturation temperature, compressor return gas temperature, and cooler entering and leaving fluid temperatures.
- 6) Chilled fluid flow switch.

- b. Unit controls shall include the following functions as standard:

- 1) Automatic circuit lead/lag.
- 2) Capacity control based on leaving chilled fluid temperature and compensated by rate of change of return-fluid temperature with temperature setpoint accuracy to 0.1 ° F (0.06° C).
- 3) Limiting the chilled fluid temperature pull-down rate at start-up to an adjustable range of 0.2° F to 2° F (0.11° C to 1.1° C) per minute to prevent excessive demand spikes at start-up.
- 4) Seven-day time schedule.
- 5) Leaving chilled fluid temperature reset from return fluid, outdoor-air temperature, space temperature, or 4 to 20 mA input.
- 6) Demand limit control with 2-stage control (0 to 100% each) or through 4 to 20 mA input (0 to 100%).
- 7) Chilled and condenser water pump start/stop control.
- 8) Dual chiller control for series chiller applications without addition of hardware modules or additional thermistors.
- 9) Dual chiller control for parallel flow applications use one additional sensor.
- 10) Amperage readout per compressor with %MTA per compressor.

- c. The control panel shall include, as standard, a portable hand held display module with a minimum of 4 lines and 20 characters per line, of clear English, Spanish, Portuguese or French language. Display menus shall provide clear language descriptions of all menu items, operating modes, configuration points and alarm diagnostics. Reference to factory codes shall not be accepted. An industrial grade coiled extension cord shall allow the display module to be moved around the chiller. Magnets shall hold the display module to any sheet metal panel to

allow hands-free operation. Display module shall have NEMA 4x housing suitable for use in outdoor environments. Display shall have back light and contrast adjustment for easy viewing in bright sunlight or night conditions. The display module shall have raised surface buttons with positive tactile response.

- d. The chiller controller shall include multiple connection ports for communicating with the local equipment network, the Carrier Comfort Network (CCN) and the ability to access all chiller control functions from any point on the chiller.

- e. The control system shall allow software upgrade without the need for new hardware modules.

2. Safeties:

Unit shall be equipped with thermistors and all necessary components in conjunction with the control system to provide the unit with the following protections:

- a. Loss of refrigerant charge.
- b. Reverse rotation.
- c. Low chilled fluid temperature.
- d. Low oil pressure (each compressor circuit).
- e. Voltage imbalance.
- f. Ground current fault.
- g. Thermal overload.
- h. High pressure.
- i. Electrical overload.
- j. Loss of phase.
- k. Current imbalance.
- l. Loss of flow.

3. Diagnostics:

- a. The display module shall be capable of indicating the safety lockout condition by displaying the information in clear language at the display. Information included for display shall be:

- 1) Compressor lockout.
- 2) Loss of charge.
- 3) Low fluid flow.
- 4) Low oil pressure.
- 5) Cooler freeze protection.
- 6) High or low suction superheat.
- 7) Thermistor malfunction.
- 8) Entering and leaving-fluid temperature.
- 9) Evaporator and condenser pressure.
- 10) Electronic expansion valve positions.
- 11) All set points.
- 12) Time of day.

Guide specifications (cont)



- b. Display module, in conjunction with the microprocessor, must also be capable of displaying the output results of a service test. Service test shall verify operation of every switch, thermistor, and compressor before chiller is started. User shall be able to force each output device.
- c. Diagnostics shall include the ability to review a list of the 20 most recent alarms with clear language descriptions of the alarm event. Display of alarm codes without the ability for clear language descriptions shall be prohibited.
- d. An alarm history buffer shall allow the user to store no less than 20 alarm events with clear language descriptions, time and date stamp event entry.

H. Operating Characteristics:

Unit shall be capable of starting up with 95 F (35 C) entering fluid temperature to the cooler.

I. Electrical Requirements:

- 1. Unit primary electrical power supply shall enter the unit at a single location (some units have multiple power poles).
- 2. Unit shall operate on 3-phase power at the voltage shown in the equipment schedule.
- 3. Control voltage shall be 115-v (60 Hz) or 230-v (50 Hz), single-phase, separate power supply.
- 4. Unit shall be shipped with factory control and power wiring installed.

J. Special Features:

Certain standard features are not applicable when the features designated by * are specified. For assistance in amending the specifications, contact your local Carrier Sales office.

- * 1. Wye-Delta Starter:
Unit shall have a factory-installed, Wye-Delta starter to minimize electrical inrush current.
- 2. Sound Reduction Enclosure:
Unit shall have field-installed sound reduction enclosure which covers the entire unit to muffle compressor noise.
- 3. Vibration Isolation:
Unit shall be supplied with rubber-in-shear vibration isolators for field installation.

- 4. Control Power Transformer:
Unit shall be supplied with a field-installed transformer that will supply control circuit power from the main unit power supply.
- 5. Temperature Reset Sensor:
Unit shall reset leaving chilled fluid temperature based on outdoor ambient temperature or space temperature when this sensor is installed.
- * 6. Brine Option:
Unit shall be factory modified to start and operate at leaving chilled fluid temperatures of between 15 F (-9 C) and 40 F (4.4 C).
- * 7. Minimum Load Control:
Unit shall be equipped with factory (or field) installed, microprocessor-controlled, minimum load control that shall permit unit operation down to 10% of full capacity.
- 8. Multi-Chiller Control:
Control shall enable management of multiple parallel chillers (up to 8) or two (2) chillers in series in a single system.
- 9. Minus-One-Pass Cooler:
Factory-installed option shall reduce pressure drop for high flow applications. Shall also provide same end inlet and outlet for 076-106 sizes and opposite end inlet for 116-271 sizes.
- 10. Plus-One-Pass Cooler:
Factory-installed option shall enhance low temperature brine performance.
- 11. Suction Service Valves:
Unit shall be supplied with factory-installed suction service valves.
- 12. Cooler Head Insulation:
Unit shall be supplied with field-installed cooler insulation that shall cover the cooler heads.
- 13. Energy Management Module:
A factory or field installed module shall provide the following energy management capabilities: 4 to 20 mA signals for leaving fluid temperature reset, cooling set point reset or demand limit control; 2-point demand limit control (from 0 to 100%) activated by a remote contact closure; and discrete input for "Ice Done" indication for ice storage system interface.



Manufacturer reserves the right to discontinue, or change at any time, specifications or designs without notice and without incurring obligations.